

# SEEDTEC®

The Leading Name in  
Surface Grinders



## NC / CNC Precision Surface Grinder



OVER 30 YEARS EXPERIENCE

CE

ISO 9001:2008

# Experience Technology Reliability

## **SEEDTEC®** The Leading Name In Surface Grinders

### **SEEDTEC® Surface Grinder Provides**

- Precision
- Fine Finish
- Reliability
- Productivity



**SEEDTEC®** machinery Co.,Ltd. has more than 20 years of experience in design and manufacturing precision surface grinders. Since the company established, **SEEDTEC®** has been dedicated to providing customers with the very best machinery available for achieving the highest levels of accuracy, durability, and reliability.

Experience, technology, innovation and reliability are the fundamental principles our company is built on. During the years we continuously improve our company management and constantly look for better ways to improve machine performance. **SEEDTEC®** is the first company certified by CE among the surface grinder manufacturers in Taiwan.

In addition, **SEEDTEC®** is also certified by ISO 9001:2008 currently **SEEDTEC®** precision surface grinders have been sold to many countries around the world.

Based on our strong technical background in the field of surface grinder, **SEEDTEC®** also looks into the future with confidence, and will enter into the new century helping customers to create more profits.

# SEEDTEC®

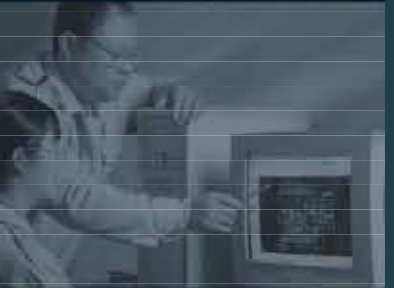
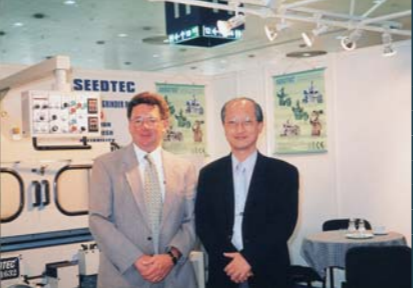

SEEDTEC® APS-S SERIES

# The Answer to Perfect Grinding

## APS-S SERIES 3 Axes Servo Drive

APS-618S    APS-818S    APS-1224S    APS-1228S  
APS-1632S    APS-1636S    APS-1640S

The APS-S series 3 axes servo surface grinder from SEEDTEC® lets you perform high precision grinding more efficiently by optimizing the capacity of your surface grinder.

It will give you competitive edge for precision parts machining year after year.

- 3 axes servo motor with precision ball screws drive to maximize efficiency and positioning accuracy.
- Outstanding longitudinal feed rate design allows for heavy grinding at low speed feed for grinding hard and brittle materials such as glass, quartz and ceramic, etc.
- High precision reversing motion for longitudinal movement makes the machine excellent for grinding spline parts, injection pins and punches etc.
- Simple, easy-to-use CNC control enhances overall efficiency.
- Variable longitudinal travel speed is easily and simply controlled by using knob.
- Super precision vertical linear guide ways combined with extra large slide blocks for greatly increasing rigidity of spindle.
- Vertical servo motor with precision ball screw permits feed unit setting to 0.001mm.
- With the use of application programs (optional) combined with graphical and conversational parameters input, the machine can perform plunge grinding, (Including multi-slots grinding ) and flat surface grinding (or stepped surface grinding)
- Over wheel parallel manual dresser with auto dressing amount compensated to vertical axis is available for optional.
- Available to increase spindle motor horsepower up to 5 HP (for APS-618/818 series) (OPT.)  
Available to increase spindle motor horsepower up to 20 HP (for APS-1224/1228 series) (OPT.)  
Available to increase spindle motor horsepower up to 30 HP (for APS-1632/1636/1640 series) (OPT.)
- Patented control panel greatly upgrades operational convenience (Patented No. 219605)
- Rational design of panel provides convenient operation. All keys and buttons are designed as easily identified figures.
- Total thermal stability assures lifetime accuracy.
- Unique safety features incorporated in the control. Motion controls are effected only when buttons are pressed with two fingers for safety protection.



Picture shown with optional coolant system c/w paper filter

CE

**SEEDTEC® APS-P SERIES**

# The Modern Way to Productivity and Profit.

**APS-P SERIES  
X-Axis Hydraulic  
Y, Z-Axis Servo Drive.**

APS-618P    APS-818P    APS-1224P    APS-1228P  
APS-1632P    APS-1636P    APS-1640P

When your parts need more efficiency grinding yet without sacrificing surface accuracy and finish, you want the quality proven grinder that will help you to get it.

**SEEDTEC® APS-P Series Surface Grinder** is the right choice. With hydraulic drive on x-axis and servo drive on y, z-axis, the APS-P series is designed and manufactured with profitable machining in mind.

- Cross and vertical feed are driven by servo motors combined with precision ball screws transmission for greatly upgrading efficiency and positioning accuracy.
- Longitudinal movement is driven by high performance hydraulic system. (feed rate range 0.1~25m/mim.)
- High positioning accuracy (0.005mm) for longitudinal movement permits the dresser device to perform accurate wheel dressing.
- Available to equip with table-mounted diamond roll dresser or pop dresser with one or three diamond tools for profiling.(OPT.)  
Dressing amount is automatically compensated to vertical axis, making it ideal for mass production requirement.
- Super precision vertical linear guide ways combined with extra large slide blocks for greatly increasing rigidity of spindle.
- Vertical servo motor with precision ball screw permits feed unit setting to 0.001mm.
- With the use of application programs (optional) combined with graphical and conversational parameters input, the machine can perform plunge grinding, (Including multi-slots grinding ) and flat surface grinding (or stepped surface grinding)
- Over wheel parallel manual dresser with auto dressing amount compensated to vertical axis is available for optional.
- Available to increase spindle motor horsepower up to 5 HP (for APS-618/818 series) (OPT.)  
Available to increase spindle motor horsepower up to 20 HP (for APS-1224/1228 series) (OPT.)  
Available to increase spindle motor horsepower up to 30 HP (for APS-1632/1636/1640 series) (OPT.)
- Patented control panel greatly upgrades operational convenience (Patented No. 219605)
- Rational design of panel provides convenient operation. All keys and buttons are designed as easily identified figures.
- Total thermal stability assures lifetime accuracy.
- Unique safety features incorporated in the control. Motion controls are effected only when buttons are pressed with two fingers for safety protection.
- Especially ideal for multi-slotting, such as Connector / IC package mould components and automatic grinding-off.



Picture shown with optional overwheel parallel manual dresser with auto dressing amount compensated to vertical axis

CE

# Heavy Duty Meehanite Castings

To ensure lifetime accuracy and maximum stability under heavy duty grinding, the structural parts on *SEEDTEC*® grinder are manufactured from Meehanite cast iron, scientifically rib reinforced to resist flexing and provide better dampening capacity.

- ▶ All major castings are tempered and stress relieved for deformation-free on the structure.
- ▶ Widely spaced base slideways eliminate the suspension problem for table longitudinal travel.
- ▶ Heavy duty column structure provides extra rigid support for the grinding head.



## Finite Element Analysis

The major casting parts on the *SEEDTEC*® machines are analyzed by the most advanced "Finite Element Analysis" to achieve optimum structure design.

Through computer analysis, we can fully understand structure deformation in heavy loading condition. *SEEDTEC*® machines feature unmatched rigidity and stability comparing to conventional models.

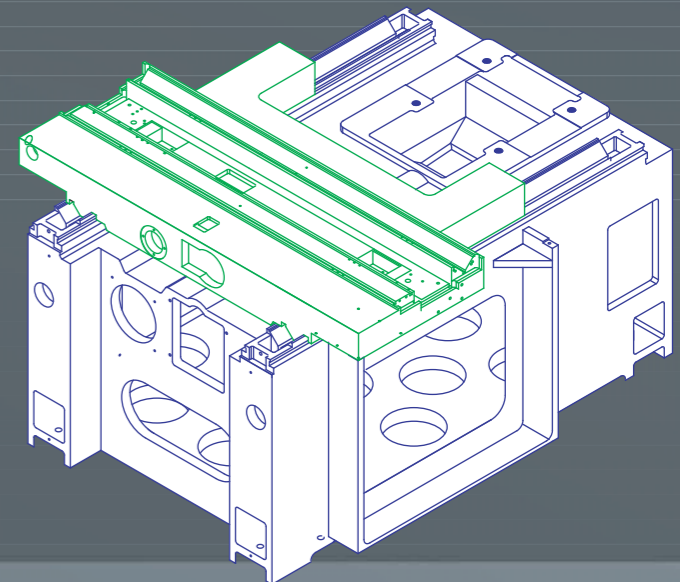

# Precision Spindle Assures High Quality Grinding

**SEEDTEC**® precision spindle is manufactured from high quality alloy steel, precision ground and dynamically balanced for high speed smooth running.

The precision spindle is supported by a combination of class P4 double super precision angular contact ball bearings for maximum rigidity, chatter-free operation and assure high quality grinding year after year.

Completely sealed spindle avoid contamination of coolant and abrasive dust getting in.

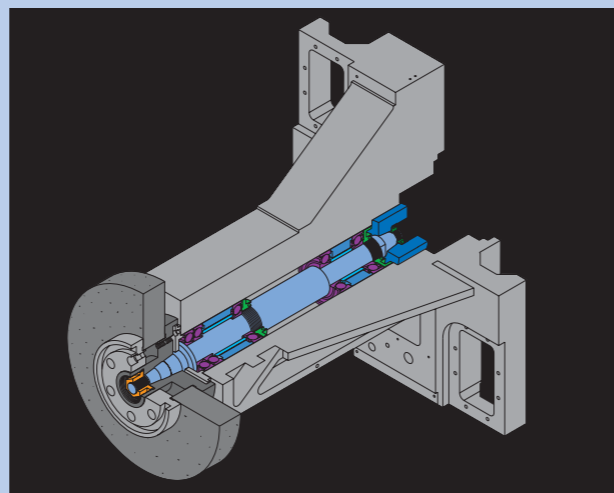

## SPEED/TORQUE DIAGRAM

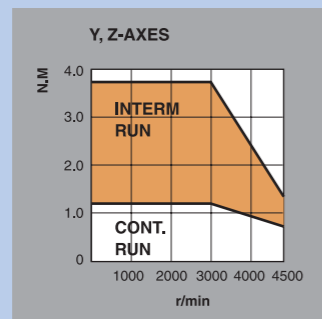
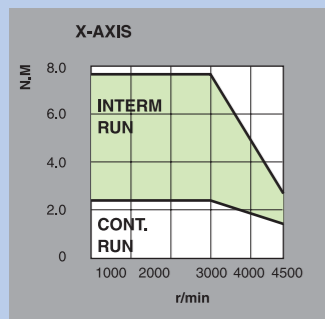

## Pop Dresser with one or Three Diamond Tools

The Pop Dresser is mounted at the side of electro-magnetic chuck. When perform wheel dressing, the dresser pop over the electro-magnetic chuck to facilitate dressing motions.

Available to use single diamond tool for straight dressing, or use three diamond tools for bevel surface or arc dressing. Dressing amount is compensated to vertical axis.



## Diamond Roll Dresser

The Roll dresser is mounted at the side of electro-magnetic chuck. Designed for dressing forming wheel on mass production. Wheel dressing is performed according the shape of roll.

Once the grinding wheel is worn out, it is convenient to dress by using the roll dresser. Dressing amount is compensated to vertical axis.

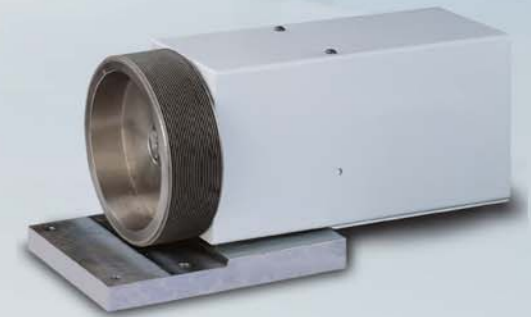

## Hydraulic Power Unit for APS-P Series Only

The longitudinal movement on APS-P series is driven by high performance hydraulic system. It employs world famous Vickers hydraulic parts, assuring extra smooth motion for continuous long time operation, minimum trouble and long service life.



## Hydraulic Oil Temperature Controller (Optional)

The hydraulic power unit is available to equip with an oil temperature controller for maintaining oil temperature at the room temperature with tolerance  $\pm 1.2^{\circ}\text{C}$ . It effectively eliminates thermal displacement of the machine while assuring outstanding grinding accuracy.



# Operator-friendly Controller

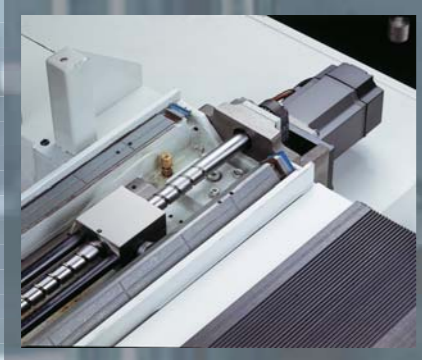

## Precision Ball Screws and servo Motor on 3 Axes APS-S Series

High precision ball screws are used on the x, y, z axes. Ball screws are pretensioned to minimize thermal strain, backlash and pitch error. 3 axes ball screws are driven by servo motors with power transmitted by timing belt for positive transmission.



## Vibration-Free Wheel Head APS-618 and 818 Series

The spindle head assembly is indirectly driven by a servo motor through timing belt transmission. This fully eliminates the possibility of vibration to the spindle assembly, resulting in high accuracy grinding.



## Linear Motion Guides

The Y axis employ high rigidity linear guideways that ensures high positioning and repeatability accuracy, lower friction, and smooth traverse.

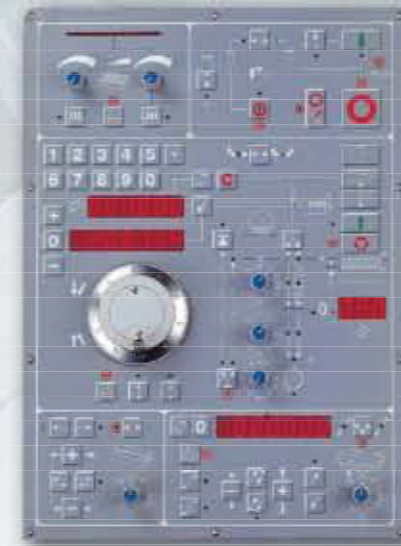

The controller equipped on **SEEDTEC**® surface grinder is designed specifically for automatic grinding control, which utilizes the advanced control technology. The simple, easy-to-use control features reduced programming time, improved surface quality and consistent production quality.

## The Advanced Control Makes Your Grinding Operations More Efficient By:

- UTC400P is a general-purposed controller built with the most advanced 32-bit digital signal processor and programmable gate array.
- It supports linear interpolation, circular interpolation and screwed intrpolation; up to 4 axes could be in one coordinate.
- With its excellent computational ability, UTC400P can perform complex arithmetic and logic computation that makes program design easy.

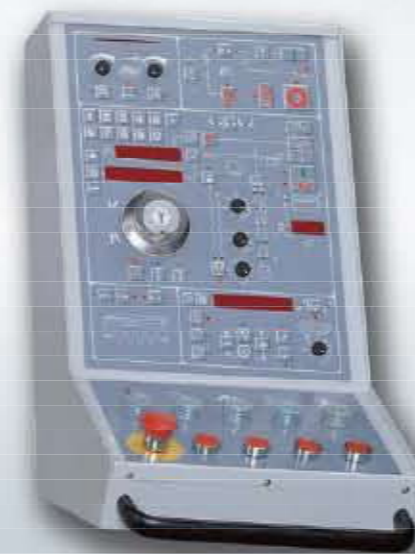

## Advanced Control Exclusive Control Panel Design Patented No. 219605

- The control buttons and machining parameters input fully meet grinding sequences and are easy to operate.
- All key functions are indicated by graphical symbols for easy identification.
- Coarse and fine grinding feed are set by variable regulation knob, providing fast responding to feed adjustment without setting any parameter for increasing efficiency.
- LEDS' lights clearly indicate machining conditions.
- Specially designed remote hand wheel provides user-friendly operation.

## CNC Control (Optional)



**FANUC:**  
Oi Series



**MITSUBISHI:**  
M70V Series



## PC Touch-sensing Screen:

It allows the operator to edit programs as desired with conversational input.

## Applicable machining programs include:

1. Multi-Plunge grinding / step surface grinding.
2. Contour grinding.

# Specifications

ITEM		MODEL	618P	618S	818P	818S	1224P	1224S	1228P	1228S	1632P	1632S	1636P	1636S	1640P	1640S
CAPACITY	Maximum grinding (length x width)		480 x 150 mm		480 x 200 mm		650 x 300 mm		750 x 300 mm		850 x 400 mm		950 x 400 mm		1050 x 400 mm	
	Maximum distance from table top to spindle center line		95-510 mm		95-510 mm		700 mm		700 mm		700 mm		700 mm		700 mm	
TABLE	Table surface (length x width)		460 x 150 mm		460 x 200 mm		600 x 300 mm		700 x 300 mm		800 x 400 mm		900 x 400 mm		1000 x 400 mm	
	Maximum longitudinal travel		530 mm	510 mm	530 mm	510 mm	700 mm	660 mm	800 mm	760 mm	900 mm	870 mm	1000 mm	970 mm	1100 mm	1070 mm
	Maximum cross travel		170 mm		220 mm		360 mm		360 mm		460 mm		460 mm		460 mm	
	T-slot(NO.x width)		1 x 14 mm		1 x 14 mm		3 x 17 mm		3 x 17 mm		3 x 17 mm		3 x 17 mm		3 x 17 mm	
FEED	<b>Longitudinal movement of table</b>															
	Hydraulic feed		0.1-25 M/min		0.1-25 M/min		1-25 M/min		1-25 M/min		1-25 M/min		1-25 M/min		1-25 M/min	
	Continuous traverse feed		0-25 M/min		0-25 M/min		0-25 M/min		0-25 M/min		0-25 M/min		0-25 M/min		0-25 M/min	
	Hand feed per revolution		69 mm		69 mm		65 mm		65 mm		65 mm		65 mm		65 mm	
	<b>Cross movement of saddle</b>															
	Intermittent feed		0.15 mm-10 mm	0-12 mm	0.15 mm-10 mm	0-12 mm	1-15 mm		1-15 mm		1-15 mm		1-15 mm		1-15 mm	
	Continuous transverse feed		1200 mm/min		1200 mm/min		1800 mm/min		1800 mm/min		1800 mm/min		1800 mm/min		1800 mm/min	
	Hand feed per revolution		0.1 mm-5 mm		0.1 mm-5 mm		0.1 mm-5 mm		0.1 mm-5 mm		0.1 mm-5 mm		0.1 mm-5 mm		0.1 mm-5 mm	
	Graduation of handwheel		0.001-0.05 mm		0.001-0.05 mm		0.001-0.05 mm		0.001-0.05 mm		0.001-0.05 mm		0.001-0.05 mm		0.001-0.05 mm	
	<b>Vertical movement of wheel head</b>															
	Hand feed per revolution		0.1-1 mm		0.1-1 mm		0.1-1 mm		0.1-1 mm		0.1-1 mm		0.1-1 mm		0.1-1 mm	
	Graduation of handwheel		0.001-0.01 mm		0.001-0.01 mm		0.001-0.01 mm		0.001-0.01 mm		0.001-0.01 mm		0.001-0.01 mm		0.001-0.01 mm	
Rapid feed		800 mm/min		800 mm/min		1200 mm/min		1200 mm/min		1200 mm/min		1200 mm/min		1200 mm/min		
SPINDLE & WHEEL	Spindle motor		1.5 KW / 2P (OPT. 3.7 KW / 2P)		1.5 KW / 2P (OPT. 3.7 KW / 2P)		3.7 KW / 4P (OPT. 15 KW / 4P)		3.7 KW / 4P (OPT. 15 KW / 4P)		5.5 KW / 4P (OPT. 22 KW / 4P)		5.5 KW / 4P (OPT. 22 KW / 4P)		5.5 KW / 4P (OPT. 22 KW / 4P)	
	Spindle speed (60/50HZ)		3460 / 2860 rpm		3460 / 2860 rpm		1455 / 1755 rpm		1455 / 1755 rpm		1455 / 1755 rpm		1455 / 1755 rpm		1455 / 1755 rpm	
	Grinding wheel outside diameter x thickness		Ø205 mm x 13t		Ø205 mm x 19t		Ø355 / Ø305 mm x 50t		Ø355 / Ø305 mm x 50t		Ø355 / Ø305 mm x 50t		Ø355 / Ø305 mm x 50t		Ø355 / Ø305 mm x 50t	
	Grinding wheel bore		Ø31.75 mm		Ø31.75 mm		Ø127 mm		Ø127 mm		Ø127 mm		Ø127 mm		Ø127 mm	
MOTOR	Hydraulic		2.2 KW / 4P		2.2 KW / 4P		3.7 KW / 4P		3.7 KW / 4P		3.7 KW / 4P		3.7 KW / 4P		3.7 KW / 4P	
	Cross feed (AC servo)		400 W		400 W		400 W		400 W		750 W		750 W		750 W	
	Vertical feed (AC servo)		400 W		400 W		400 W		400 W		400 W		400 W		400 W	
	Longitudinal feed (AC servo)		750 W		750 W		1000 W		1000 W		1500 W		1500 W		1500 W	
FLOOR SPACE & WEIGHT	Floor space(LxWxH)		2110 x 2400 x 1752 mm		2110 x 2400 x 1752 mm		3240 x 2500 x 2092 mm		3240 x 2500 x 2092 mm		3300 x 2780 x 2092 mm		3350 x 2780 x 2092 mm		3400 x 2780 x 2092 mm	
	Weight(Approx.)		1600 KGS		1650 KGS		3200 KGS		3200 KGS		4000 KGS		4000 KGS		4200 KGS	
	Packing dimensions(LxWxH)		1880 x 1820 x 2020 mm		1880 x 1820 x 2020 mm		2560 x 2150 x 2170 mm		2660 x 2150 x 2170 mm		3150 x 2300 x 2170 mm		3200 x 2300 x 2170 mm		3250 x 2300 x 2170 mm	

NOTE: As SEEDTEC is constantly improving the design of its machines, appearance, specifications, dimensions and weights are subject to be changed without notice.

# Dimensional Drawings

(unit: mm)

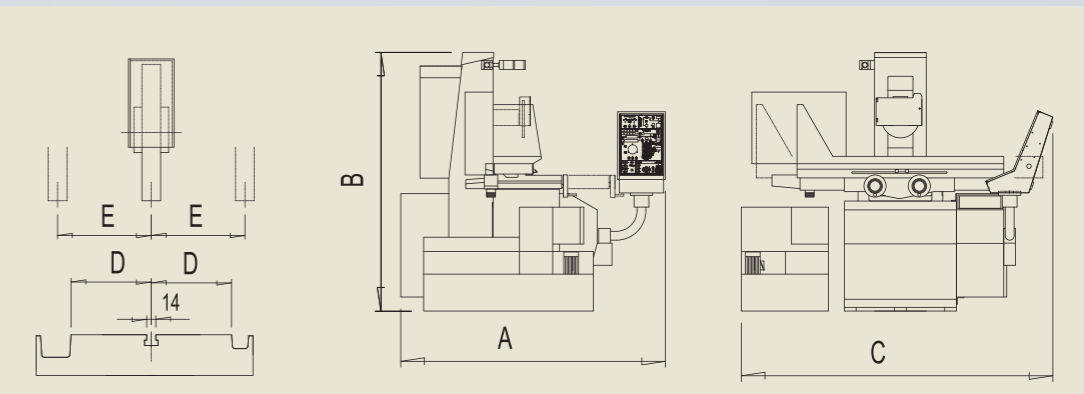

MODEL NO	APS-618P/S	APS-818P/S
A	2400	2400
B	1752	1752
C	2110	2110
D	75	100
E	85	110

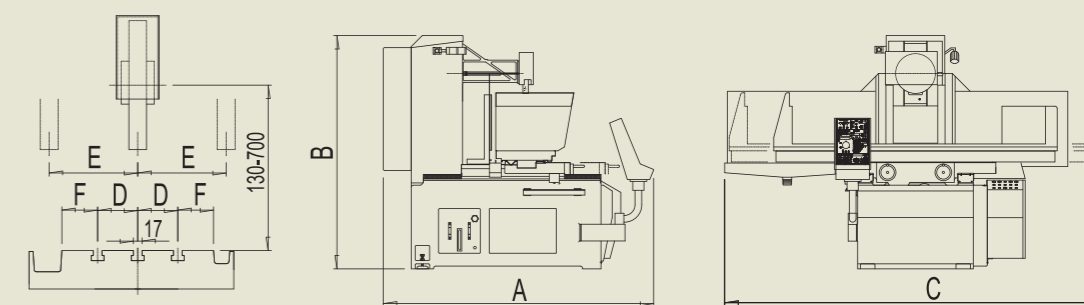

MODEL NO	APS-1224P/S	APS-1228P/S	APS-1632P/S	APS-1636P/S	APS-1640P/S
A	2500	2500	2780	2780	2780
B	2092	2092	2092	2092	2092
C	3240	3240	3300	3350	3400
D	100	100	100	100	100
E	180	180	230	230	230
F	50	50	100	100	100

SEEDTEC®



### APS-618.818 Series Standard Accessories:

ITEM	DESCRIPTION	QTY
1.	Grinding wheel (Dia. x Thickness x Bore) ø205 x 13 x 31.75m/m(APS-618) or ø205 x 19 x ø31.75m/m(APS-818)	1
2.	Grinding wheel adaptor & puller	1
3.	Arbor for wheel balancing	1
4.	Diamond tool (1/4 carat) with a base	1 EACH
5.	Dust sweeping plate	1
6.	Working lamp	1
7.	Leveling plates	6
8.	Leveling bolts with nut	6
9.	Eyebolt	2
10.	T-nut (#14) & Screws (M10 x 40)	2
11.	Necessary tools with a tool box	1
	A. Wrench (36m/m)	1
	B. Hexagon-headed spanner (2.5,3,4,5,6,8m/m)	1 EACH
	C. Adjustable wrench (200m/m)	1
	D. Cross screw driver (#4)	1
	E. Pouched ratchet box wrenches	1
12.	Lubrication oil (4 liters, Mobil #1405)	1
13.	Operation manual and inspection certificate	1 EACH
14.	Spare paint	1

### APS-1224.1228.1632.1636.1640 Series Standard Accessories:

ITEM	DESCRIPTION	QTY
1.	Grinding wheel (Dia. x Thickness x Bore) ø305 x 50 x ø127m/m(60Hz) or ø355 x 50 x ø127m/m(50Hz)	1
2.	Grinding wheel adaptor & puller	1
3.	Arbor & nut for wheel balancing	1 EACH
4.	Diamond tool (1/4 carat) with a base	1 EACH
5.	Dust sweeping plate	1
6.	Working lamp	1
7.	Leveling plates	4
8.	Leveling bolts with nut	4
9.	Eyebolt	1
10.	T-nut (#16) & Screws (M10 x 50)	2
11.	Necessary tools with a tool box	1
	A. Wrench (36m/m)	1
	B. Hexagon-headed spanner (2.5,3,4,5,6,8m/m)	1 EACH
	C. Adjustable wrench (375mm)	1
	D. Cross screw driver (#4)	1
12.	Lubrication oil (16 liters, Mobil #1405)	1
13.	Operation manual and inspection certificate	1 EACH
14.	Spare paint	1

### Optional Accessories:

- (1001) Permanent magnetic chuck (Standard type/inclining type)
- (1002) Grinding wheel balancing apparatus
- (1003) Spare grinding wheel adaptor
- (1004) Dust suction System
- (1005) Coolant System
- (1006) Coolant & dust suction System (For APS-618/818 series)
- (1007) Inverter
- (1008) Digital read out for cross/vertical movement
- (1012) Radius dressing device
- (1013) Angle dressing device
- (1014) Punch former(For APS-618/818 series)
- (1015) Sine vise
- (1016) Tool maker vise
- (1017) Sine plate with permanent magnetic chuck
- (1019) Demagnetizer(AC110V/220V)  
(For permanent magnetic chuck)
- (1020) Automatic demagnetizing controller  
(For electro-magnetic chuck)

- (1021) Electro-magnetic chuck (Standard type/inclining type)
- (1022) Consistent temperature control for hydraulic system  
(For APS-P model)
- (1023) Optical-dresser with microscope (x10)
- (1024) Coolant system C/W a magnetic dust separator
- (1025) Coolant system with paper filter
- (1027) Coolant system with paper filter C/W a magnetic dust separator
- (1030) Overwheel parallel manual dresser with auto dressing  
amount compensated to vertical axis
- (1031) Optical radius angle dresser
- (1032) Dynamic balancer for grinding wheel
- (1033) Powered conditioning tools for diamond & CBN wheel
- (1034) Table-mounted diamond roll dresser
- (1035) Diamond roll dresser mounted on wheel head
- (1036) Table-mounted pop dresser with one or three diamond  
tools for profiling
- (1037) CNC controller (FANUC or MITSUBISHI or .....)

# SEEDTEC®

## SEEDTEC MACHINERY CO., LTD.

No. 135 Renmei Rd., Dali Dist. Taichung, 41282 TAIWAN.

TEL: 886-4-2492 1628

FAX: 886-4-2492 1680

http://www.seedtec.com.tw

E-mail: seedtec@ms26.hinet.net