



www.bandsaw.com.tw



鎂佳機械工業股份有限公司
MEGA MACHINE CO.,LTD.

台灣 · 41154 台中市太平區工業路180號
No.180, Industrial Road, Tai-ping District, Taichung City, 41154, Taiwan R. O. C.
www.bandsaw.com.tw
Tel:+886-4-22712877(Rep.) Fax: +886-4-22715016
E-Mail: sales@bandsaw.com.tw

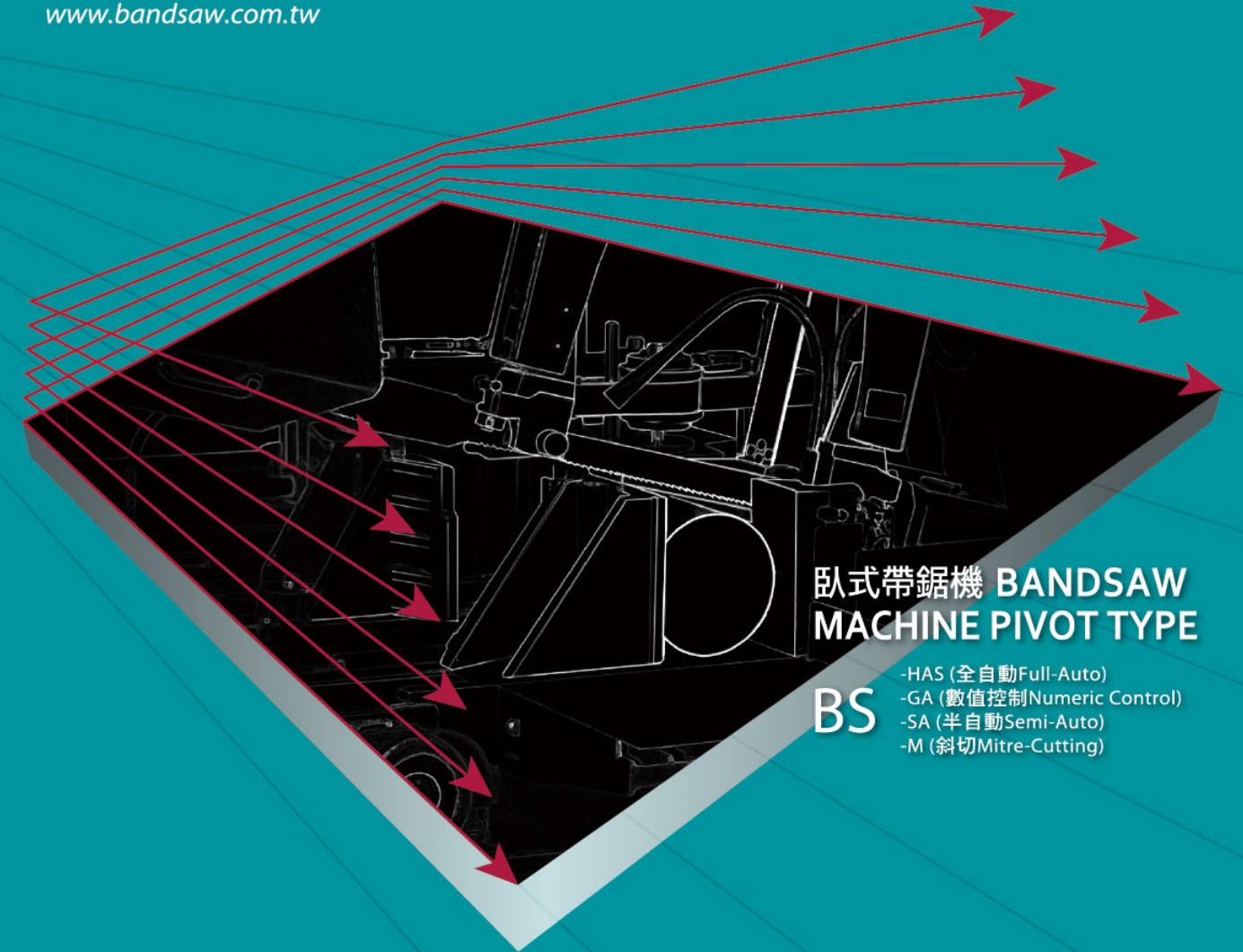

臥式帶鋸機 BANDSAW
MACHINE PIVOT TYPE

- BS
- HAS (全自動Full-Auto)
 - GA (數值控制Numeric Control)
 - SA (半自動Semi-Auto)
 - M (斜切Mitre-Cutting)



Official Website

2021.03
886-4-2296-5959

Keep Improving & Quality Oriented -Skillful engineering and imaginative design give every MEGA Band Saw Machine exceptional cutting capacity.
不斷創新與精進&嚴格執行品質要求-以操作者為出發點的設計,並追求完美的品質

全自動油壓臥式帶鋸機 FULL AUTOMATIC HORIZONTAL BANSAWS	P3
BS-250HAS/GA	P7
BS-300HAS/GA	P9
BS-400HAS/GA	P11
BS-450HAS/GA	P13
半自動油壓臥式帶鋸機 (手動進料) SEMI-AUTO HORIZONTAL BANSAWS (MANUAL BAR FEED)	P15
BS-400SA	P17
BS-450SA	P17
BS-1830	P17
半自動角度切削帶鋸機 (動力馬達轉台旋轉切削裝置) SEMI-AUTO HORIZONTAL BANSAWS (POWER TURNING TABLE MITRE CUTTING)	P19
BS-450M	P21
BS-760M	P23
BS-1000M	P25
機台外觀尺寸 MACHINE DIMENSIONS	P27

安全設計 – 每一鎂佳機械的帶鋸機皆有以下特點
SAFETY DESIGN- Every MEGA Band Saw is factory equipped with

1. 安全及熱過載開關 Safety and thermal overload switches.
2. 鋸帶及鋸輪安全保護蓋 Well guarded blades and wheel covers.
3. 切削完畢鋸帶自動停止 Saw Blade shuts off automatically when cutting is completed.
4. 低電壓及零電壓控制 Low voltage & zero voltage controls.
5. 鋸帶斷帶偵測 (半自動為選配) A blade breakage sensor/motion detector provides automatic shut-off. (Optional for manual/semi-auto models)



不斷創新與精進

今天做得要比昨天做得更好，明天做得要比今天做得還要好，是我們不斷創新，研究發展的精神所在。因為我們深知沒有成長就是退步，沒有創新就是落伍。鎂佳所以兢兢業業，奮發努力，為的是要提供經濟、完美的產品，貢獻業界來降低生產成本，減少胚料損失，提高生產能量，增進原胚料精度，提升自動化程度，促進技術升級，減少能源浪費。

嚴格執行品質要求

我們把機器當作是藝術品來處理，每個過程小心翼翼，要求盡善盡美，不容許有任何瑕疵。因為我們知道，為客戶提供完善的售後服務，不厭其煩的服務態度並不能使客戶完全滿足，唯有完美的品質，近乎免於服務的機器，才是我們追求的最大目標。

以操作者為出發點的設計

客戶的要求，操作者的願望，是本公司一系列帶鋸機設計的參考藍本，以機器來配合人們的操作，而不是以人來配合機器，正是我們全力追求的目標，因此，鎂佳的鋸床，結構剛強，操作容易，安全性高，鋸切能力強勁快速，精密度高，機件、鋸片持久耐用生產能量大，人工最省。

精良產品永續經營

鎂佳機械工業股份有限公司，創立於西元 1980 年，成立以全自動油壓帶鋸機、NC 全自動圓鋸機、精密油壓滾牙機、CNC 螺絲磨床之研發、製造、組裝及銷售服務的專業廠商。

KEEP IMPROVING

MEGA's R&D has over thirty-year experiences thus forms a strong team. It can provide total solution in screw and gear rolling, metal and nonferrous cutting, worm and thread grinding.

QUALITY ORIENTED

MEGA quality policy: "High performance and best quality can catch customers' heart, turning quality into company's "Super Salesman".

CUSTOMIZED FOR YOU

MEGA could provide total solution to meet your production requirement.

PERPETUAL MANAGEMENT

Since 1980,MEGA machine Co.,Ltd has been specializing in designing, producing and assembling, serving customers with bandsaw machine, NC circular saw machine, thread rolling machine and CNC thread grinding machine.

隨研發的改進，本公司保有設計變更產品規格的權力與解釋權，確定規格、尺寸、產品資訊以實品為準，若有變更恕不另行通知。 Specifications are subject to change for improvement and modification without prior notice.

BS-HAS/GA 全自動油壓臥式帶鋸機

FULL AUTOMATIC HORIZONTAL BANDSAWS

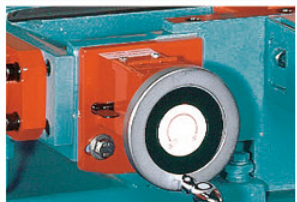

精確的鋸切長度設定裝置 PRECISE CUT OFF LENGTH SETTING

在操作者易於操作的位置，本機裝設了一個方便的、數位顯示的鋸切長度預設裝置，使能夠很精確的、快速的設定所希望鋸切的長度。它的設定單位是 0.1mm，而且能夠在鋸切途中改變下次要鋸切的尺寸，不需停機。A convenient digital readout control located at the operator's station provides easy selection of precise bar length requirement. The digital readout is calibrated in 0.10 mm or 0.01 IN increments and can be repositioned without interrupting the cutting cycle.



鋸帶自動抬高與快速接近設計 AUTO HEAD-ELEVATION AND QUICK APPROACH

在自動鋸切循環中，機台能自動昇高至離材料適當的高度，操作者不用再費心注意。而且，在機台下降鋸切行程中，此一裝置能夠自動控制機台快速接近工作物，使剛好要在鋸片接觸材料之前，轉換為正常鋸切的下降速度，這一點在自動鋸切循環中，可省去相當多的空車時間。Raising the blade higher than necessary to clear the work for the next cut wastes time. Head elevation is controlled automatically and no longer requires the operator's attention. A control device that senses the size of the work piece permits the saw head to raise just high enough so the blade clears the work. This reduces index cycling time significantly.



整把鋸切裝置 NESTING FIXTURE

此一裝置是由本機兩組夾鉗外，另再附設之兩組上壓夾鉗所組成，它能夠把整把的材料穩固的夾緊，以免在鋸切行程中材料產生震動、鬆動，而影響鋸切的精度和鋸片的折損。對於整把棒材、管材非得用此一裝置不可。The hydraulically-operated nesting fixture is designed for high-production multiple sawing of stacked bars, small rounds and tubing. The fixture contains vertical cylinders mounted on the index and front vises. It holds stacked work firmly to assure accurate cuts and prevent center bars from turning.

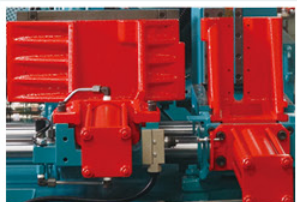

快速雙夾鉗，3 點夾持系統 QUICK-ACTION HYDRAULIC TWIN-VISE (SPLIT)3-JAW CLAMPING

設有前後兩組油壓夾鉗來夾緊工作物，前面的主夾鉗更設有雙夾鉗面，總共三點夾持，當鋸切時，鋸片由主夾鉗兩夾鉗面中央，往下鋸切。此一設計在鋸切細長的棒材時，能更穩固的夾緊工作物，以免工作物旋轉。Materials are firmly clamped on both sides of the saw blade by twin vises. Operating a single switch provides manual or automatic clamping and unclamping materials. This unique design of vise clamps work-piece firmly to avoid material from vibrating or turning while cutting long and thin/small bars/tubes.



獨立雙開送料夾鉗 UNIQUE TWO-WAY CARRIAGE VISE JAW

後送料座上的那組夾鉗，可雙向同步動作，即同時打開或同時夾緊，一般鋸床只有一邊可打開和夾緊，固定邊不能動。此一設計最大的好處在於材料表面不平或彎曲時仍可達到精確的送料長度。Both vise jaws on the rear work-carriage are actuated simultaneously, opening or closing, instead of the traditional one that is fixed one side moveable on the other. This particular design ensures accurate indexing even warped stock.



鋸切數量 / 九段送料裝置 / LED 鋸帶速度顯示

CUTTING PIECE COUNTER / MULTIPLE STROKE COUNTER / LED BLADE SPEED DISPLAY

鋸切數量計數器用來預先設定所希望鋸切的材料數量。在自動鋸切循環中，當已達到預先設定的數目時，機械會自動停止。九段送料裝置用來控制鋸切長度的倍數，比如一次送料行程可達 400mm，九次可送料 3600mm 長。The cutting piece counter is used to preset the number of cuts required on automatic operation. When the counter reaches the preset number, the saw automatically stops. The multiple stroke counter makes it possible to multiply the number of index cycles. When pieces longer than 400mm /16in (500mm/20in for BS450HAS) are required, the number of strokes can be preset on the counter. The counter is capable of being set to a maximum of nine strokes: 144" /180" .



動力鋼刷輪 POWER-DRIVEN SAW-BAND BRUSH

動力鋼刷輪由強力冷卻液噴刷，確保鋸刀切削時無鐵屑。A power-driven saw-band brush, continually flushed by a cutting fluid spout, keeps the blade and saw guides free of chips for smoother cutting. A flush hose is available for washing chips and debris away from the cutting area.

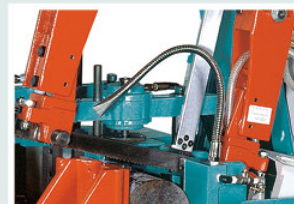

快速螺旋式碳化鎢導鋸 QUICK-ADJUSTING CARBIDE SAW-BAND GUIDES

本機全部採用碳化鎢導鋸片來導引鋸帶，使鋸帶能具有剛性和直線精度。而碳化鎢的鬆緊則採用螺旋來操作，不但省力，而且快速，操作者要更換新的鋸帶時使用此一設計可說是輕鬆容易。(550/600/700 機型為油壓式導鋸)For the replacement of the saw blade or the repositioning of the guide arms, two levers are incorporated in the saw guides to allow these operations to be carried out quickly and efficiently.(Hydraulic carbide guides on 550/600/700 models.)



鋸片旋轉偵測系統 IDLE WHEEL MOTION DETECTOR

此一裝置能保護鋸片於過負載切削時免於折損，因為過負載切削，鋸片會卡住於材料中，它能立即偵知停機，而避免繼續下降機台而折斷鋸片。另外，鋸片沒張緊或是意外折斷亦能自動停機。The device not only can protect the saw blade from damage if the blade overloads during cutting, but will also shut off the machine if the blade breaks.

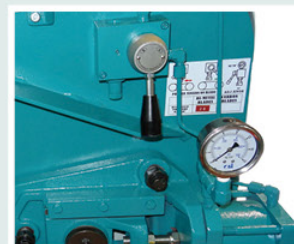

油壓鋸帶張力控制 HYDRAULIC BAND TENSION CONTROL

鋸帶切削中張力自動被保持；當關機時，鋸帶張力自動放鬆，能增加鋸帶壽命。During operation of the saw the correct tension is automatically maintained. The tension is reduced when the saw shuts off. This procedure greatly increases blade life.

BS-HAS/GA 全自動油壓臥式帶鋸機 FULL AUTOMATIC HORIZONTAL BANDSAWS

選擇配備 Optional Equipment

進給控制系統 Cutting feed rate system

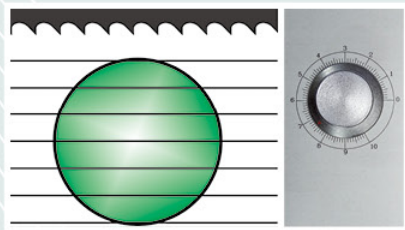

標準 Standard

標準切削進給系統
Standard cutting feedrate system

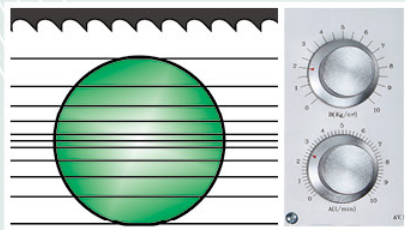

增幅閥 (選配) With Amplifying valve (OPT.)

增幅閥自動調整切削進給率達到最佳切削效果
Amplifying valve for auto adjusting optimized cutting feedrate system.
(Optional available on all models)

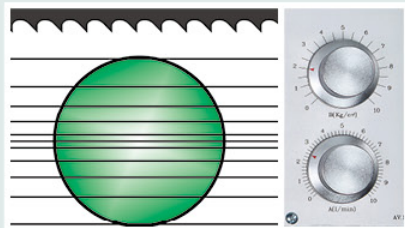

增幅閥 +GA (選配僅適用於全自動機種) Amplifying valve +GA (Optional for automatic models)

GA 系列自動切削長度電腦數值控制 GA Numeric control
適用於所有自動機種的選配功能，只要將切削長度及數量輸入觸控面板內，機器就能自動將工件鋸切成預設的長度和數量 (有九種或至多 99 種不同的長度 + 數量可設定) For all automatic models, input length and numbers of cuts data into the incorporated touch screen, and the work pieces will be automatically cut into the pre-set lengths and the required numbers (9 or up to 99 different courses available)

如圖顯示不同進給控制系統，請詢問詳細內容以便適合您的需求。

Pictures demonstrated above are different control systems optional available, please ask for full details of a model suited to your particular cutting requirements.

鎂佳機械 GA 系列鋸床特色

九種切削長度及數量設定

九種切削長度及數量設定僅需透過觸控面板的簡單操作。九組切削資訊會同時顯示在 LED 顯示面板上，目前切削數量則透過燈號閃爍來顯示。

自動送料長度補償

觸控螢幕允許設定多組自動切削數值，包含切長料的間隙損失誤差補償，可省去煩人的計算過程。

自動錯誤偵測

精密的自我偵測系統會不斷的監測電腦內部狀態。如果有錯誤發生，機台會立即停止運作，錯誤碼會顯示在螢幕上。



數值控制 GA Numeric Control

增幅閥 Amplifying Valve

Special features for all MEGA GA series bandsaws

Nine-course setting of length and number of cuts

Cut-off length and the number of cuts can be set in nine courses by simple key-in operation. Total nine cutting data are shown on the touch screen at the same time. The current number of cuts is indicated by blinking signal lights.

Automatic kerf loss compensation

The touch screen permits automatic setting of multiple indexes including kerf loss in long-length cutting. No need for troublesome calculating procedure.

Automatic errors, signals display

The sophisticated self-diagnosis system constantly monitors the internal state of the computer. Should a failure occur, machine operation will be stopped and the error number of the defective position is indicated.

BS-250HAS/GA 全自動油壓臥式帶鋸機

FULL AUTOMATIC HORIZONTAL BANDSAWS



規格表 Specifications

規格 / 機型 SPEC. / MODEL	BS-250 HAS/GA	
鋸切能力 Cutting Capacity	mm	● 260 ■ 300W X 180H 或 or ■ 280W X 250H
	in	● 10 ■ 12W X 7H 或 or ■ 11W X 10H
整把切削 Bundle Cutting	mm	200W X 140H
	in	8W X 5.5H
鋸帶尺寸 Blade Size	mm	34W X 1.10t X 3660L
	in	1.34W X 0.043t X 144L
鋸帶速度 Blade Speed	M/min	25,32,42,55,70,80 無段變速 Variable Speed 20-80 (選配 Opt.)
	F/min	82,105,138,180,230,260 無段變速 Variable Speed 65-260 (選配 Opt.)
馬達 Motor Output	HP	鋸帶 Blade 3; 油壓 Hyd. 1; 冷卻 Coolant 1/8
	KW	鋸帶 Blade 2.25; 油壓 Hyd.0.75; 冷卻 Coolant 0.1
封箱尺寸 (L X W X H) Shipping Volume	mm	2120 X 2090 X 1500
	ft	6.9 X 6.8 X 4.9
淨重 / 毛重 N.W. / G.W.	kg	1380 / 1610
	lb	3036 / 3542

標準配備 Standard Equipment

工具箱 Tools with tool box	1 只 set
2M(7 ft.) 長滾輪台 Long roller table with vertical rollers	1 台 set
清屑鋼刷輪 Band-cleaning wire brush	1 件 pc
鋸帶 Bandsaw blade	1 條 pc
操作手冊 Instruction manual	1 本 copy

選擇配備 Optional Equipment

1. 自動清屑系統 Automatic chip conveyor.
2. 鋸速無段變速 Variable blade-speed drive.
3. 夾鉗壓力可調 Variable vise pressure system.
4. 鋸切速率調整用增幅閥 Amplifying valve for auto-adjusting cutting feed-rate.
5. 額外之送料台、清屑鋼刷輪、鋸帶、工作燈 Additional spare roller table, wire brush, saw blade, work-area light, etc.

BS-300HAS/GA 全自動油壓臥式帶鋸機

FULL AUTOMATIC HORIZONTAL BANDSAWS



規格表 Specifications

規格 / 機型 SPEC. / MODEL	BS-300 HAS/GA	
鋸切能力 Cutting Capacity	mm	● 330 ■ 350W X 250H 或 or ■ 300W X 300H
	in	● 13 ■ 13W X 10H 或 or ■ 12W X 12H
整把切削 Bundle Cutting	mm	250W X 165H
	in	10W X 6.5H
鋸帶尺寸 Blade Size	mm	34W X 1.10t X 3820L
	in	1.34W X 0.043t X 150L
鋸帶速度 Blade Speed	M/min	25,32,42,55,70,80 無段變速 Variable Speed 20-80 (選配 Opt.)
	F/min	82,105,138,180,230,260 無段變速 Variable Speed 65-260 (選配 Opt.)
馬達 Motor Output	HP	鋸帶 Blade 5; 油壓 Hyd. 1; 冷卻 Coolant 1/8
	KW	鋸帶 Blade 3.7; 油壓 Hyd.0.75; 冷卻 Coolant 0.1
封箱尺寸 (L X W X H) Shipping Volume	mm	2120 X 2090 X 1600
	ft	6.9 X 6.8 X 5.3
淨重 / 毛重 N.W. / G.W.	kg	1410 / 1640
	lb	3102 / 3608

標準配備 Standard Equipment

工具箱 Tools with tool box	1 只 set
2M(7 ft.) 長滾輪台 Long roller table with vertical rollers	1 台 set
清屑鋼刷輪 Band-cleaning wire brush	1 件 pc
鋸帶 Bandsaw blade	1 條 pc
操作手冊 Instruction manual	1 本 copy

選擇配備 Optional Equipment

1. 自動清屑系統 Automatic chip conveyor.
2. 鋸速無段變速 Variable blade-speed drive.
3. 夾鉗壓力可調 Variable vise pressure system.
4. 鋸切速率調整用增幅閥 Amplifying valve for auto-adjusting cutting feed-rate.
5. 額外之送料台、清屑鋼刷輪、鋸帶、工作燈 Additional spare roller table, wire brush, saw blade, work-area light, etc.
6. GA 型切削長度電腦數值控制 GA Numeric control.

BS-400HAS/GA 全自動油壓臥式帶鋸機

FULL AUTOMATIC HORIZONTAL BANDSAWS

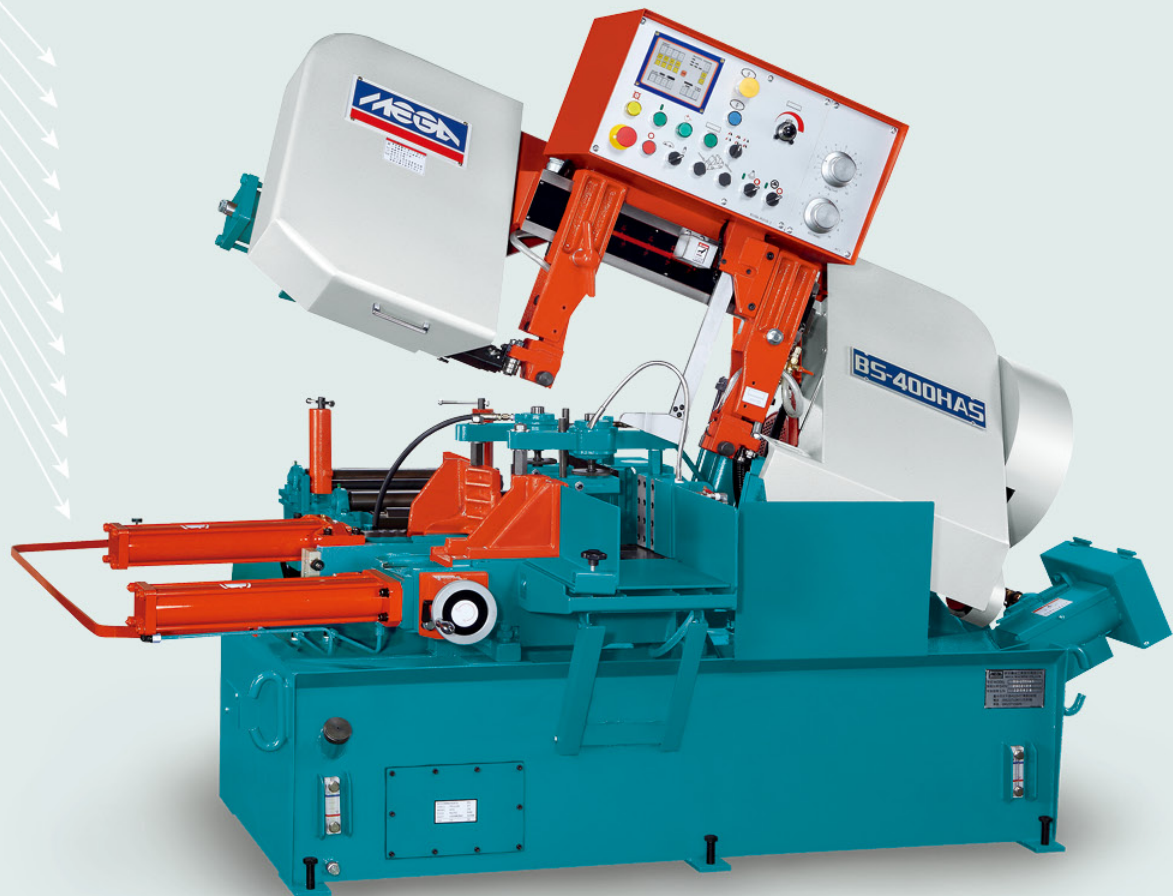

規格表 Specifications

規格 / 機型 SPEC. / MODEL	BS-400 HAS/GA	
鋸切能力 Cutting Capacity	mm	● 400 ■ 400W X 320H
	in	● 16 ■ 16W X 12 1/2H
整把切削 Bundle Cutting	mm	320W X 205H
	in	13W X 8H
鋸帶尺寸 Blade Size	mm	34W X 1.10t X 4115L
	in	1.34W X 0.043t X 162L
鋸帶速度 Blade Speed	M/min	25,32,42,55,70,80 無段變速 Variable Speed 20-80 (選配 Opt.)
	F/min	82,105,138,180,230,260 無段變速 Variable Speed 65-260 (選配 Opt.)
馬達 Motor Output	HP	鋸帶 Blade 5; 油壓 Hyd. 1; 冷卻 Coolant 1/8
	KW	鋸帶 Blade 3.73; 油壓 Hyd.0.75; 冷卻 Coolant 0.1
封箱尺寸 (L X W X H) Shipping Volume	mm	2150 X 2240 X 1770
	ft	7 X 7.3 X 5.8
淨重 / 毛重 N.W. / G.W.	kg	1630 / 1950
	lb	3585 / 4290

標準配備 Standard Equipment

工具箱 Tools with tool box	1 只 set
2M(7 ft.) 長滾輪台 Long roller table with vertical rollers	1 台 set
清屑鋼刷輪 Band-cleaning wire brush	1 件 pc
鋸帶 Bandsaw blade	1 條 pc
操作手冊 Instruction manual	1 本 copy

選擇配備 Optional Equipment

1. 自動清屑系統 Automatic chip conveyor.
2. 鋸速無段變速 Variable blade-speed drive.
3. 夾鉗壓力可調 Variable vise pressure system.
4. 鋸切速率調整用增幅閥 Amplifying valve for auto-adjusting cutting feed-rate.
5. 額外之送料台、清屑鋼刷輪、鋸帶、工作燈 Additional spare roller table, wire brush, saw blade, work-area light, etc.
6. GA 型切削長度電腦數值控制 GA Numeric control.

BS-450HAS/GA 全自動油壓臥式帶鋸機

FULL AUTOMATIC HORIZONTAL BANDSAWS

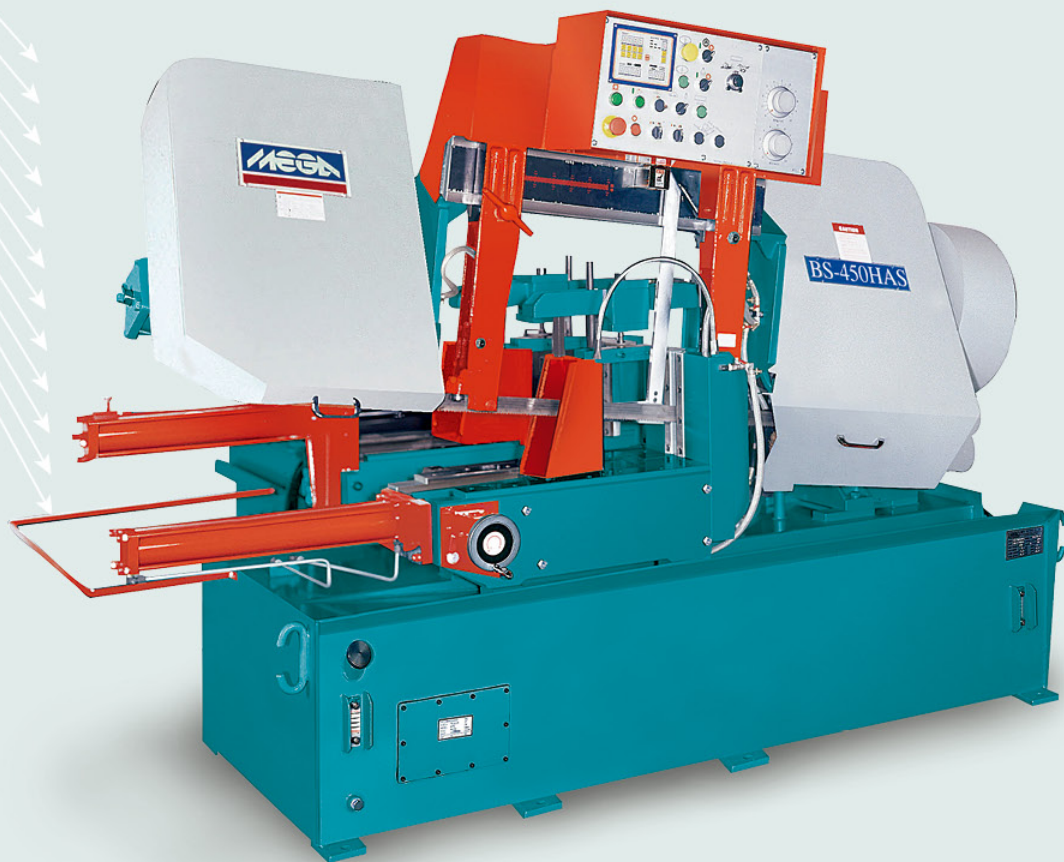

規格表 Specifications

規格 / 機型 SPEC. / MODEL	BS - 450HAS/GA	
鋸切能力 Cutting Capacity	mm	● 460 ■ 460W X 407H
	in	● 18 ■ 18W X 16H
整把切削 Bundle Cutting	mm	360W X 255H
	in	14W X 10H
鋸帶尺寸 Blade Size	mm	41W X 1.30t X 4880L
	in	1.6W X 0.051t X 192L
鋸帶速度 Blade Speed	M/min	25,32,42,55,70,80 無段變速 Variable Speed 20-80 (選配 Opt.)
	F/min	82,105,138,180,230,260 無段變速 Variable Speed 65-260 (選配 Opt.)
馬達 Motor Output	HP	鋸帶 Blade 7.5; 油壓 Hyd.2; 冷卻 Coolant 1/8
	KW	鋸帶 Blade 5.6; 油壓 Hyd.1.5; 冷卻 Coolant 0.1
封箱尺寸 (L X W X H) Shipping Volume	mm	2540 X 2270 X 1920
	ft	8.33 X 7.43 X 6.3
淨重 / 毛重 N.W. / G.W.	kg	3100 / 3500
	lb	6820 / 7700

標準配備 Standard Equipment

工具箱 Tools with tool box	1 只 set
2M(7 ft.) 長滾輪台 Long roller table with vertical rollers	1 台 set
清屑鋼刷輪 Band-cleaning wire brush	1 件 pc
鋸帶 Bandsaw blade	1 條 pc
操作手冊 Instruction manual	1 本 copy

選擇配備 Optional Equipment

1. 自動清屑系統 Automatic chip conveyor.
 2. 鋸速無段變速 Variable blade-speed drive.
 3. 夾鉗壓力可調 Variable vise pressure system.
 4. 鋸切速率調整用增幅閥 Amplifying valve for auto-adjusting cutting feed-rate.
 5. 額外之送料台、清屑鋼刷輪、鋸帶、工作燈 Additional spare roller table, wire brush, saw blade, work-area light, etc.
- GA 型切削長度電腦數值控制 GA Numeric control.

BS-SA 半自動油壓臥式帶鋸機 (手動進料)

SEMI-AUTOMATIC HORIZONTAL BANDSAWS (MANUAL BAR FEED)



中央控制面板

所有機器操作元件集中化到控制面板，方便操作。

CENTRALIZED CONTROL PANEL

All the machine controls are centralized on a control panel, for the operator's convenience.



油壓快速作動夾鉗

夾鉗由齒排連結油壓驅動，容易調整符合材料大小尺寸。

HYDRAULIC QUICK-ACTION VISE

Vises are hydraulic operated. Tooth-rack and push-jaw features. Easily adjusted to accommodate stock size.

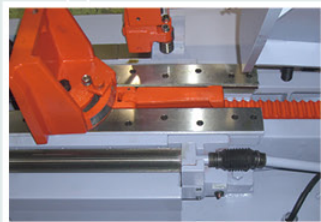

浮動滾輪機構

使用搖桿設定夾鉗及浮動滾輪，當夾鉗開啟時滾輪上升，藉著手輪輕鬆地送料前進。

FLOATING ROLLER FEED MECHANISM

Cylinder lifts stock a little to make feeding smoothly with floating roller.



自動抬頭高度控制 400SA/450SA/1830

只要設定控制鈕，便能自動控制鋸架抬高高度，方便材料的拿取。

AUTOMATIC HEAD ELEVATION CONTROL

Saw frame will raise automatically up to the height that you preset by a dial knob on the control panel, needed to clear the material being cut.

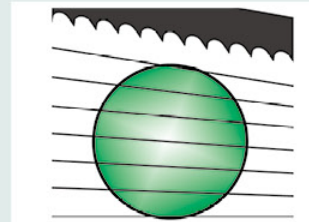

獨立的進給控制

獨立的進給控制系統由溫度及壓力補償所建立確保最大切削效能，進給控制能維持工件穩定切削。

UNIQUE FEED-RATE CONTROL

This unique feed-rate control system with built in temperature and pressure compensation ensures maximum cutting performance. The feed rate control will maintain a constant cutting rate.



動力鋼刷輪

動力鋼刷輪由強力冷卻液噴刷，確保鋸刃切削時無鐵屑。

POWER-DRIVEN SAW-BAND BRUSH

A power-driven saw-band brush, continually flushed by a cutting fluid spout, keeps the blade and saw guides free of chips for smoother cutting. A flush hose is available for washing chips and debris away from the cutting area.



快速螺旋式碳化鎢導鋸

本機全部採用碳化鎢導鋸片來導引鋸帶，使鋸帶能具有剛性和直線精度。而碳化鎢的鬆緊則採用螺旋來操作，不但省力，而且快速，操作者要更換新的鋸帶時使用此一設計可說是輕鬆容易。

QUICK-ADJUSTING CARBIDE SAWBAND GUIDES

For the replacement of the saw blade or the repositioning of the guide arms, two levers are incorporated in the saw guides to allow these operations to be carried out quickly and efficiently.

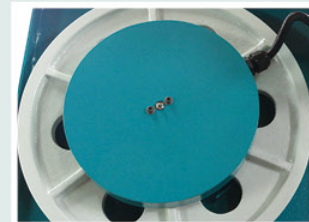

鋸片旋轉偵測系統 (選配)

此一裝置能保護鋸片於過負載切削時免於折損，因為過附載切削，鋸片會卡住於材料中，它能立即偵知停機，而避免繼續下降機台而折斷鋸片。另外，鋸片沒張緊或是意外折斷亦能自動停機。

IDLE WHEEL MOTION DETECTOR (OPTIONAL)

The device not only can protect the saw blade from damage if the blade overloads during cutting, but will also shut off the machine if the blade breaks.

BS-400SA/450SA/1830

半自動油壓臥式帶鋸機 (手動進料)

SEMI-AUTOMATIC HORIZONTAL BANDSAWS (MANUAL BAR FEED)



規格表 Specifications

規格 / 機型 SPEC. / MODEL		BS - 400 SA	BS - 450 SA	BS - 1830
鋸切能力 Cutting Capacity	mm	● 400 ■ 400W X 310H	● 460 ■ 460W X 407H	● 460 ■ 760W X 407H
	in	● 16 ■ 16W X 12H	● 18 ■ 18W X 16H	● 18 ■ 30W X 16H
斜切 Mitre Cutting	mm	280 (At 45°) (選配 Opt.)	320 (At 45°) (選配 Opt.)	N/A
鋸帶尺寸 Blade Size	mm	34W X 1.1t X 4115L	41W X 1.30t X 4670L	41W X 1.30t X 5300L
	in	1.33W X 0.043t X 162L	1.61W X 0.051t X 184L	1.61W X 0.051t X 209L
鋸帶速度 Blade Speed	M/min	25,32,42,55,70,80 無段變速 Variable Speed 20 - 80 (選配 Opt.)		
	F/min	82,105,138,180,230,260 無段變速 Variable Speed 65 - 260 (選配 Opt.)		
馬達 Motor Output	HP	鋸帶 Blade 5 ; 油壓 Hyd.1 ; 冷卻 Coolant 1/8	鋸帶 Blade 7.5 ; 油壓 Hyd.2 ; 冷卻 Coolant 1/8	鋸帶 Blade 7.5 ; 油壓 Hyd. 2 ; 冷卻 Coolant 1/8
	KW	鋸帶 Blade 3.75; 油壓 Hyd.0.75; 冷卻 Coolant 0.1	鋸帶 Blade 5.6; 油壓 Hyd.1.5; 冷卻 Coolant 0.1	鋸帶 Blade 5.6; 油壓 Hyd.1.5 ; 冷卻 Coolant 0.1
封箱尺寸 (L X W X H) Shipping Volume	mm	2210 X 1190 X 1640	2450 X 1270 X 1890	2790 X 1300 X 1830
	ft	7.25 X 3.9 X 5.38	8 X 4.1 X 6.2	9.1 X 4.2 X 6
淨重 / 毛重 N.W. / G.W.	kg	1060 / 1275	1500 / 1750	1650 / 1910
	lb	2330 / 2805	3300 / 3850	3630 / 4205

標準配備 Standard Equipment

工具箱 Tools with tool box	1 只 set
1.5M(5ft.)長滾輪台 Long roller table with vertical rollers	1 台 set
清屑鋼刷輪 Band-cleaning wire brush	1 件 pc
鋸帶 Bandsaw blade	1 條 pc
操作手冊 Instruction manual	1 本 copy

選擇配備 Optional Equipment

1. 自動清屑系統 Automatic chip conveyor.
2. 鋸帶無段變速 Variable blade speed drive.
3. 45° 斜切裝置 Mitre cutting device.
4. 外加滾輪台 Additional spare roller table.

BS-M 半自動角度切削帶鋸機 (動力馬達床台旋轉切削裝置)

SEMI-AUTOMATIC HORIZONTAL-BANDSAWS (POWER TURNING TABLE MITRE CUTTING)

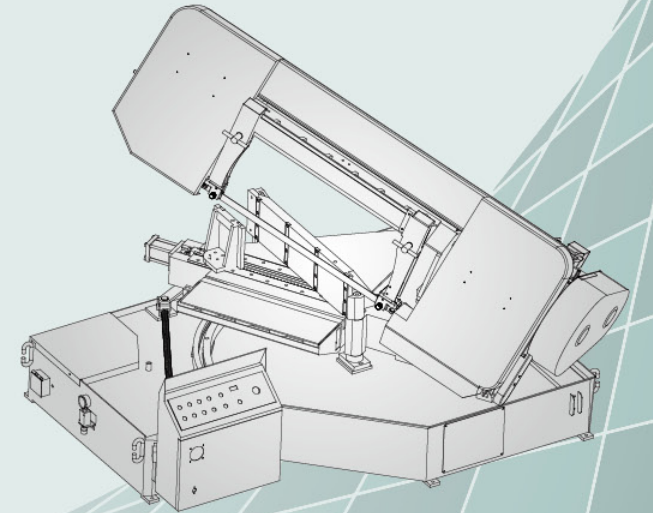
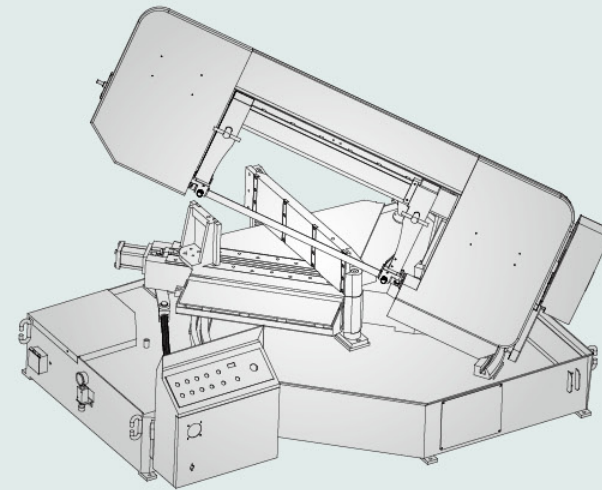
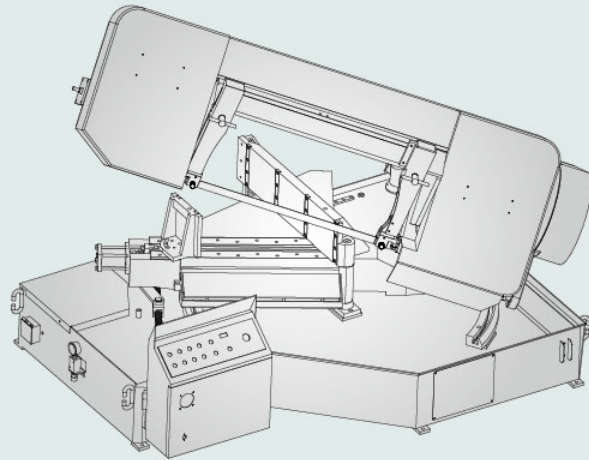
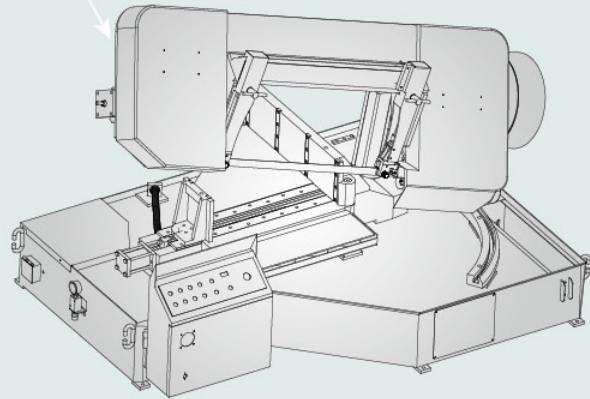
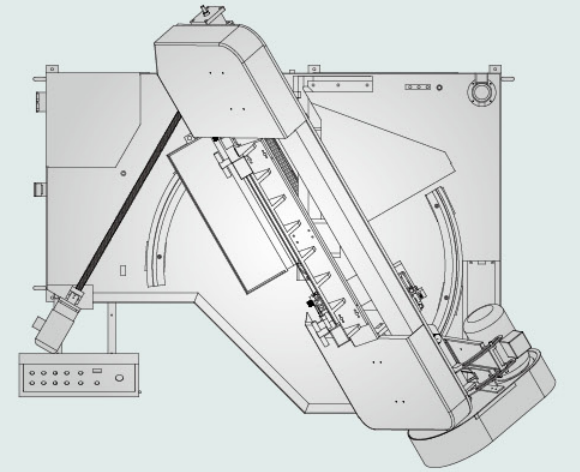
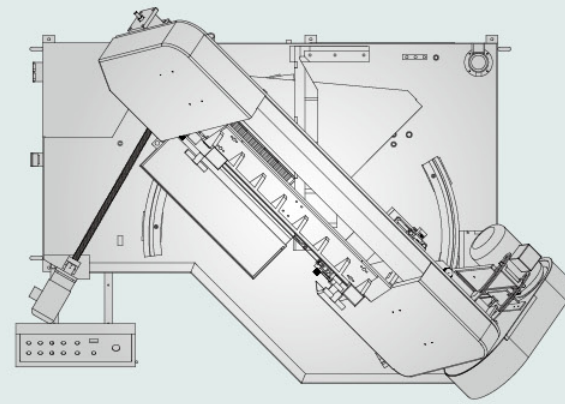
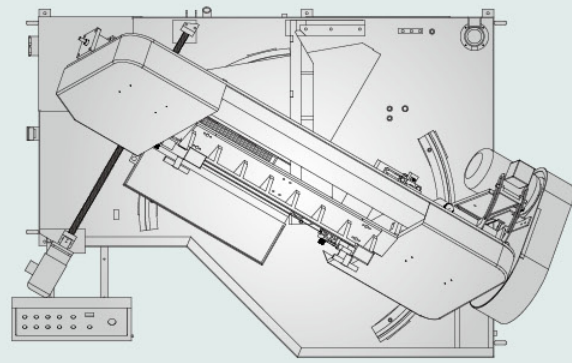
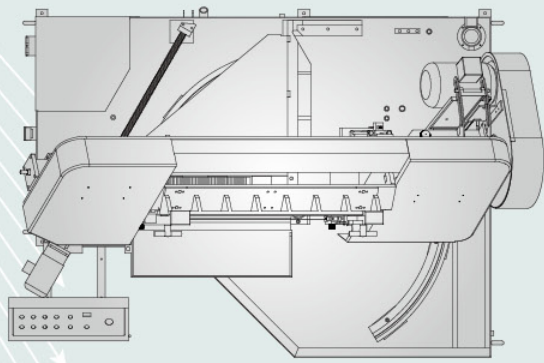

90°   60°   45°   30° 

BS-450M

半自動角度切削帶鋸機 (動力馬達床台旋轉切削裝置)
SEMI-AUTOMATIC HORIZONTAL-BANDSAWS (POWER TURNING TABLE MITRE CUTTING)



規格表 Specifications

規格 / 機型	SPEC. / MODEL	BS - 450 M
鋸切角度 Mitre Cutting At 90°	■ mm	● 320 ■ 320 ◎ 320 □ / H Beam 510W X 320H
鋸切角度 Mitre Cutting At 60°	■ mm	● 300 ■ 300 ◎ 300 □ / H Beam 357W X 320H
鋸切角度 Mitre Cutting At 45°	■ mm	● 250 ■ 250 ◎ 250 □ / H Beam 213W X 320H
鋸切角度 Mitre Cutting At 30°	■ mm	● 83 ■ 83 ◎ 83 □ / H Beam 83W X 320H
鋸帶尺寸 Blade Size	mm	34W X 1.1t X 4115L
	in	1.34W X 0.043t X 162L
鋸帶速度 Blade Speed	M/min	25,32,42,55,70,80, 無段變速 Variable Speed 25 - 80 (選配 Opt.)
	F/min	82,105,138,180,230,260 無段變速 Variable Speed 82 - 260 (選配 Opt.)
馬達 Motor Output	HP	鋸帶 Blade 5, 油壓 Hyd. 1, 冷卻 Coolant 1/8
	KW	鋸帶 Blade 3.7, 油壓 Hyd. 0.75, 冷卻 Coolant 0.1
裝箱尺寸 (L X W X H) Shipping Volume	mm	2370 X 1670 X 1790
	ft	7.7 X 5.4 X 5.8
淨重 / 毛重 N.W. / G.W.	kg	1770 / 1970
	lb	3898 / 4339

標準配備 Standard Equipment

工具箱 Tools with tool box	1 只 set
清屑鋼刷輪 Band-cleaning wire brush	1 件 pc
鋸帶 Bandsaw blade	1 條 pc
操作手冊 Instruction manual	1 本 copy

選擇配備 Optional Equipment

1. 無段式變速 Variable blade-speed drive.
2. 夾鉗壓力可調 Variable vise pressure.
3. 鋸帶偵測 Blade jam/break cutout.
4. 2M 滾輪台 Roller table.

BS-760M

半自動角度切削帶鋸機 (動力馬達床台旋轉切削裝置)
SEMI-AUTOMATIC HORIZONTAL-BANDSAWS (POWER TURNING TABLE MITRE CUTTING)



規格表 Specifications

規格 / 機型	SPEC. / MODEL	BS - 760 M
鋸切角度 Mitre Cutting At 90°	mm	● 460 ■ 460 ◎ 460 □ / H Beam 760W X 400H
鋸切角度 Mitre Cutting At 60°	mm	● 420 ■ 420 ◎ 420 □ / H Beam 590W X 400H
鋸切角度 Mitre Cutting At 45°	mm	● 330 ■ 330 ◎ 330 □ / H Beam 500W X 400H
鋸切角度 Mitre Cutting At 30°	mm	● 220 ■ 220 ◎ 220 □ / H Beam 220W X 400H
鋸帶尺寸 Blade Size	mm in	41W X 1.3t X 5500L 1.61W X 0.051t X 209L
鋸帶速度 Blade Speed	M/min F/min	25,32,42,55,70,80 無段變速 Variable Speed 25 - 28 (選配 Opt.) 82,105,138,180,230,260 無段變速 Variable Speed 82-260 (選配 Opt.)
馬達 Motor Output	HP KW	鋸帶 Blade 7.5, 油壓 Hyd. 2, 冷卻 Coolant 1/4 鋸帶 Blade 5.62, 油壓 Hyd. 1.5, 冷卻 Coolant 0.19
裝箱尺寸 (L X W X H) Shipping Volume	mm ft	2880 X 2020 X 1700 9.4 X 6.6 X 5.6
淨重 / 毛重 N.W. / G.W.	kg lb	2600 / 2900 5727 / 6388

標準配備 Standard Equipment

工具箱 Tools with tool box	1 只 set
清屑鋼刷輪 Band-cleaning wire brush	1 件 pc
鋸帶 Bandsaw blade	1 條 pc
操作手冊 Instruction manual	1 本 copy

選擇配備 Optional Equipment

1. 無段式變速 Variable blade-speed drive.
2. 夾鉗壓力可調 Variable vise pressure.
3. 鋸帶偵測 Blade jam/break cutout.
4. 2M 滾輪台 Roller table.

BS-1000M

半自動角度切削帶鋸機 (動力馬達床台旋轉切削裝置)
SEMI-AUTOMATIC HORIZONTAL-BANDSAWS (POWER TURNING TABLE MITRE CUTTING)



規格表 Specifications

規格 / 機型	SPEC. / MODEL	BS - 1000 M
鋸切角度 Mitre Cutting At 90°	mm	● 500 ■ 500 ◎ 500 □ / H Beam 1000W X 500H
鋸切角度 Mitre Cutting At 60°	mm	● 400 ■ 400 ◎ 500 □ / H Beam 800W X 485H
鋸切角度 Mitre Cutting At 45°	mm	● 350 ■ 350 ◎ 500 □ / H Beam 590W X 475H
鋸切角度 Mitre Cutting At 30°	mm	● 330 ■ 330 ◎ 330 □ / H Beam 330W X 440H
鋸帶尺寸 Blade Size	mm	54W X 1.3t X 7028L
	in	2.12W X 0.051t X 276.69L
鋸帶速度 Blade Speed	M/min	25,32,42,55,70,80 無段變速 Variable Speed 25 - 80 (選配 Opt.)
	F/min	82,105,138,180,230,260 無段變速 Variable Speed 82 - 260 (選配 Opt.)
馬達 Motor Output	HP	鋸帶 Blade 15, 油壓 Hyd. 2, 冷卻 Collant 1/4
	KW	鋸帶 Blade 11.25, 油壓 Hyd. 1.5, 冷卻 Collant 0.19
裝箱尺寸 (L X W X H) Shipping Volume	mm	3700 X 2270 X 2270
	ft	12.1 X 7.4 X 7.4
淨重 / 毛重 N.W. / G.W.	kg	4500 / 5200
	lb	10132 / 11453

標準配備 Standard Equipment

工具箱 Tools with tool box	1 只 set
清屑鋼刷輪 Band-cleaning wire brush	1 件 pc
鋸帶 Bandsaw blade	1 條 pc
操作手冊 Instruction manual	1 本 copy

選擇配備 Optional Equipment

1. 無段式變速 Variable blade-speed drive.
2. 夾鉗壓力可調 Variable vise pressure.
3. 鋸帶偵測 Blade jam/break cutout.
4. 2M 滾輪台 Roller table.

全自動油壓臥式帶鋸機 FULL AUTOMATIC HORIZONTAL BANDSAWS

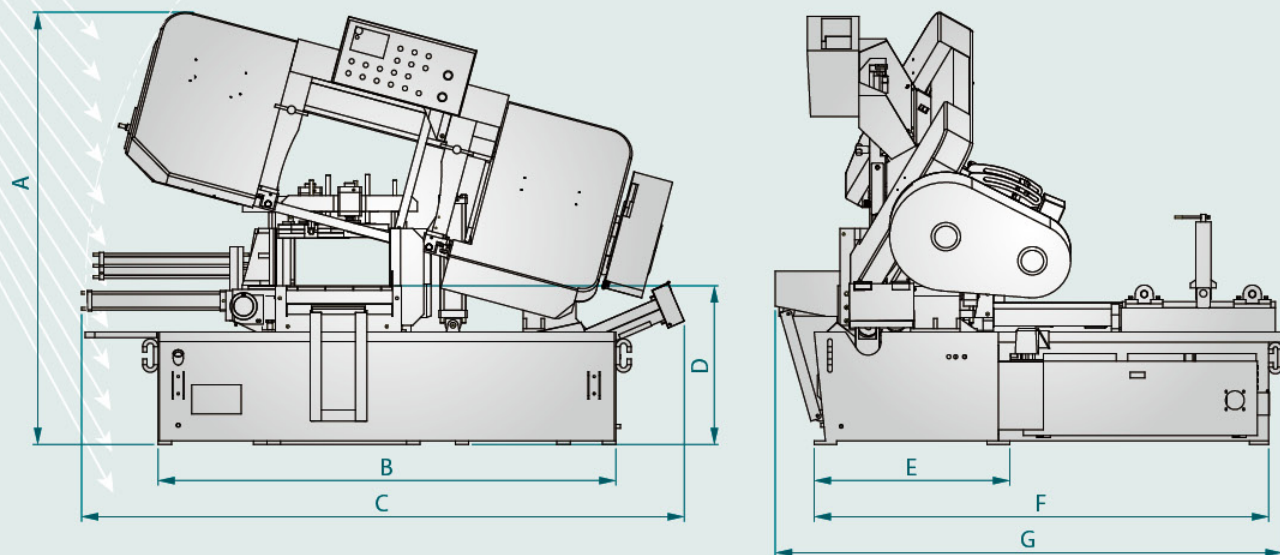

規格 / 機型 SPEC. / MODEL	單位 UNIT	A	B	C	D	E	F	G
BS-250HAS/GA	mm	1653	1550	2190	593	740	1772	1956
	inch	65.08	61.02	86.22	23.35	29.13	69.76	77.01
BS-300HAS/GA	mm	1761	1550	2199	593	740	1772	1956
	inch	69.33	61.02	86.57	23.35	29.13	69.76	77.01
BS-400HAS/GA	mm	2087	1812	2024	642	777	1890	2207
	inch	82.17	71.34	79.69	25.28	30.59	74.41	86.89
BS-450HAS/GA	mm	2305	2033	2676	704.5	868	2018	2251
	inch	90.75	80.04	105.35	27.74	34.17	79.45	88.62

半自動油壓帶鋸機 (手動進料) SEMI-AUTOMATIC HORIZONTAL BANDSAWS (MANUAL BAR FEED)

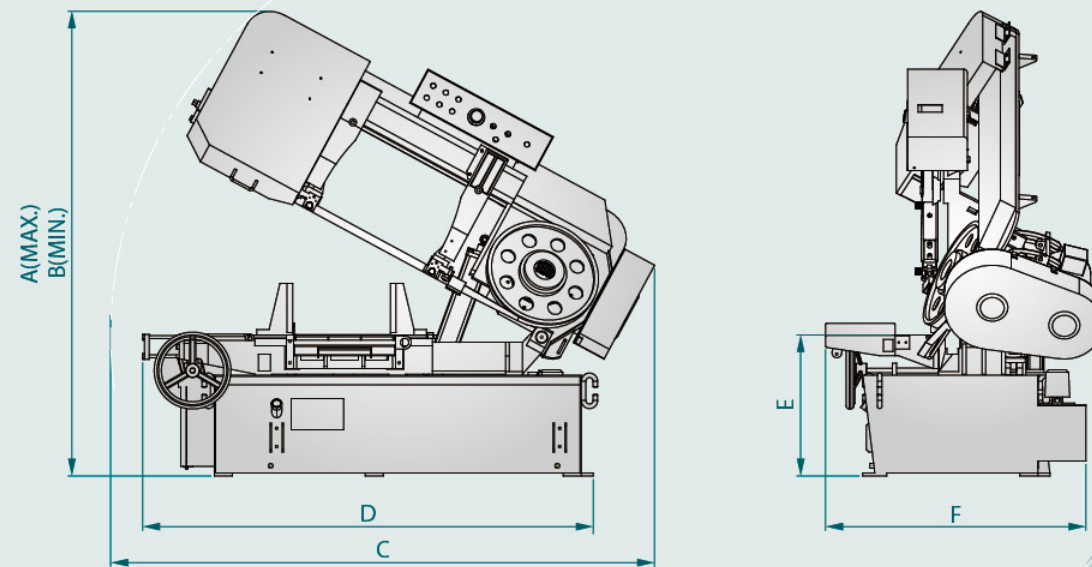

規格 / 機型 SPEC. / MODEL	單位 UNIT	A	B	C	D	E	F
BS-400SA	mm	2030	1700	2085	1320	585	740
	inch	80	67	82	52	23	29
BS-450SA	mm	2285	1805	2390	1600	685	850
	inch	90	71	94	63	27	33
BS-1830	mm	2465	2120	2705	1600	685	850
	inch	97	84	107	63	27	33

半自動角度切削帶鋸機 (動力馬達床台旋轉切削裝置)
SEMI-AUTOMATIC HORIZONTAL-BANDSAWS (POWER TURNING TABLE MITRE CUTTING)

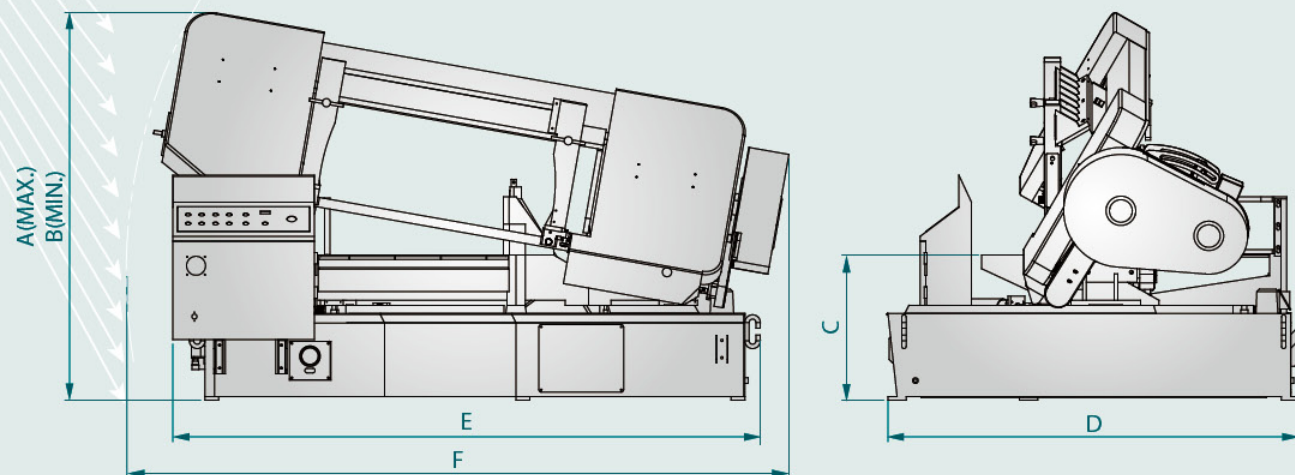

規格 / 機型 SPEC. / MODEL	單位 UNIT	A	B	C	D	E	F
BS-450M	mm	1810	1132	635	1750	1930	2100
	inch	71.3	44.6	25.0	68.9	76.0	82.7
BS-760M	mm	2400	1350	630	2200	2040	2600
	inch	94.5	53.1	24.8	86.6	80.3	102.4

半自動角度切削帶鋸機 (動力馬達床台旋轉切削裝置)
SEMI-AUTOMATIC HORIZONTAL-BANDSAWS (POWER TURNING TABLE MITRE CUTTING)

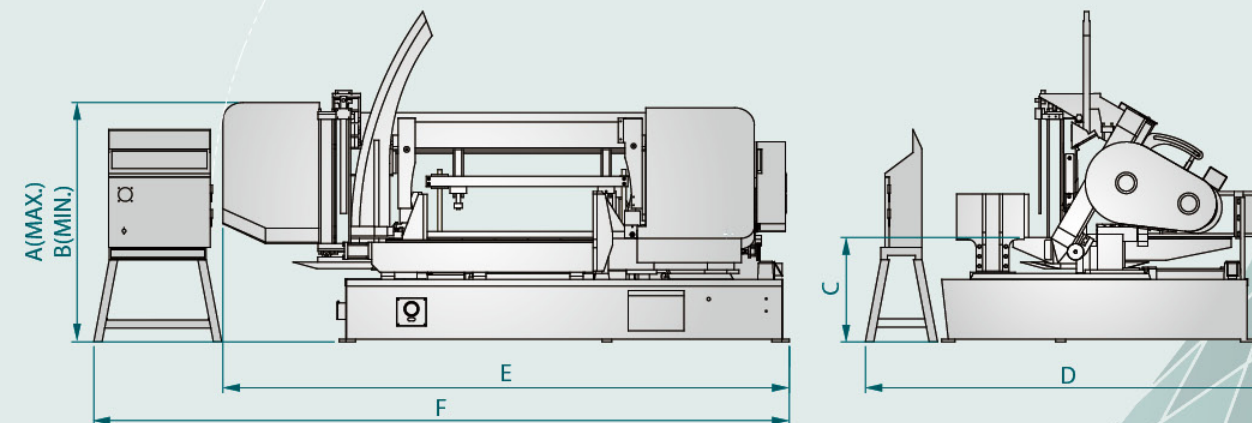

規格 / 機型 SPEC. / MODEL	單位 UNIT	A	B	C	D	E	F
BS-1000M	mm	2293	1475	635	2472	3448	4235
	inch	90.28	58.07	25.0	97.32	135.75	166.73