

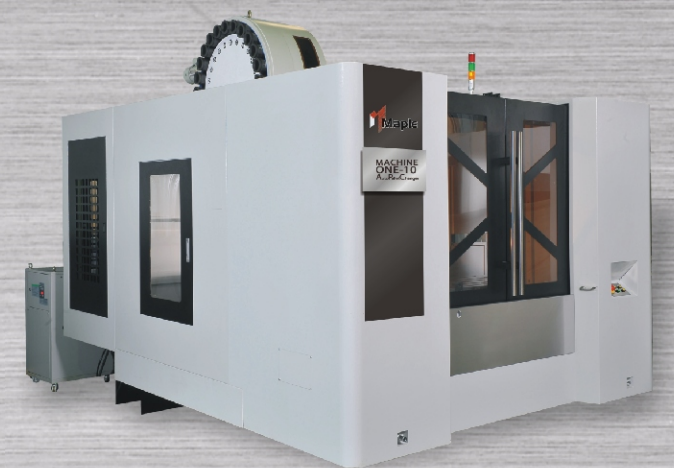

M-One APC Series by Maple



MAPLE TECHNOLOGY CO.,LTD.

No.15 Gonyequ 42nd Rd., Xitun Dist.,
Taichung Industrial Park, Taichung City,
Taiwan R.O.C 40768
Tel:+886-4-23595538 Fax:+886-4-23593439
Website:www.meple-tech.com.tw

INTRODUCING
THE MAPLE
M-One APC Series

High Speed CNC Vertical Auto Pallet Change Machining Center

With globe demand increasing, limited factory floor space, and shortage of labor force.

Many companies have been looking for solutions that can help with these increasing problems.

Look no further, Maple Technology once again has the solution to increase production with the uses of smaller limited factory floor space.

Introduction the M-One APC Series. With the M-One APC Series get 25% to 60% increase in productivity from one machine.

By not having to stop the machine after every machining cycle, this machine can work non-stop while you are changing your work pieces.

Not only can this machine increase your productivity, it can also decrease the usage of your plant floor.

The M-One Series machine only needs an extra 30% of your floor space compare to a standard vertical machining center.

Maple Technology once again brings the M-One APC Series machining center with "endless innovation".



FOUNDATION FOR QUALITY

The Perfect Platform No matter what the project a house, a skyscraper, or a suspension bridge the soundness of the structure is determined by the sturdiness of the foundation. The same principle applies to our APC machining centers. It all starts with the base and column structures. How well the machine cuts is tied to the sturdiness of the basic structure.

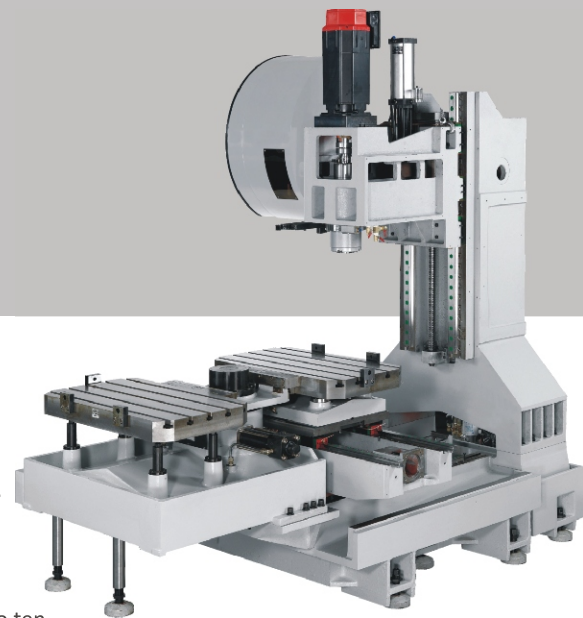

High Quality Industrial Cast-Iron Structure Cast iron provides up to ten times the damping capacity of steel. That's why Maple uses cast iron for all major components. Our castings are reinforced with heavy ribs to resist flex and damp vibrations, and inspected thoroughly before and after machining to ensure they are free of flaws.

Wide-Stance Design Our wide-stance design allow maximum structural loading with efficient use of materials. They provide a rigid and stable machining platform that resists flex, distributes cutting forces effectively, and making the machine more stable regardless of the direction of the cutting force.

Ball screw

M-One models uses high accuracy ballscrews constructed of high quality important materials that have been heat treated to prevent wear from usage. Also, the ballscrews are created with inner tubing. This design reduces noise from ballscrews travel by 20-40% compare to other standard ballscrews.



Linear guideway roller

All M-One series models uses roller type linear guide way. High strength rollers have a great weight load capacity. Furthermore, the roller type guide ways are designed to have unbelievable tilt resistance. With P-grade roller type linear guide ways, perfect flatness is guaranteed from every part machined.

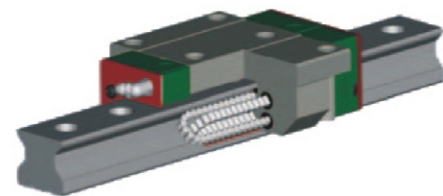

Spindle Features

- Built in (High Speed Equipment)
- Belt Driven (Standard Equipment)
- In-Line (Mid Range Equipment)
- 2-Step Gear Box (Heavy Duty Equipment)



Control Panel



4 way swivel control panel

The M-One APC model machining center features one and only 4 way swivel control panel. By being able to swivel multiple axis, the user can adjust the monitor to the perfect viewing position that the operator desires.



Chip removal back wash

The M-One APC Series does not stop working. Therefore all M-One APC series come with standard chip removal back wash system. With the limited amount of time allowed to clean the machine, the chip removal back wash system will do the cleaning for you.

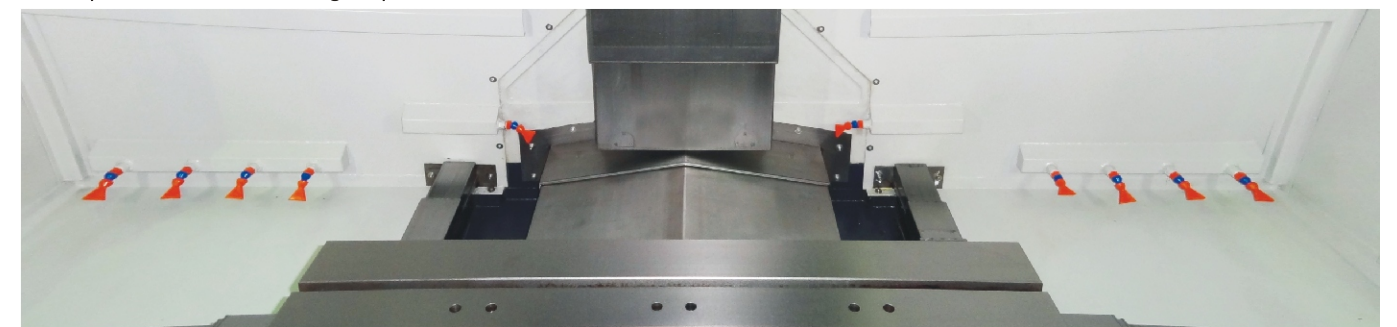

Table change time

When every second counts, a fast table change is very important. We the M-One APC fast table change is what we do. Our table change time from the moment of lift off with complete 180 degree turn only takes less than 7 seconds.



M - One APC Series

Machine Specifications:

| | | M-One6 | M-One8 | M-One10 |
|-----------------------------------|----------|----------------------------------|-----------------------|-----------------------|
| TABLE | | | | |
| Work Table Size | mm | 600 x 400 | 850 x 500 | 1000 x 500 |
| Work range | mm | 600 x 400 | 850 x 500 | 1000 x 500 |
| Number of Pallets | piece | 2 | 2 | 2 |
| T-Slot of tables | mm | 100*14*3 | 100*18*5 | 100*18*5 |
| Table Change Time | Sec. | 5 | 5 | 5 |
| Max Weight on Table | kgs | 200 x 2 | 300 x 2 | 300 x 2 |
| TRAVEL | | | | |
| X Axis | mm | 600 | 850 | 1000 |
| Y Axis | mm | 400 | 500 | 500 |
| Z Axis | mm | 500 | 600 | 600 |
| Spindle Nose to Table(min to max) | mm | 110-610 | 150-750 | 150-750 |
| SPINDLE | | | | |
| Spindle Taper | | ISO40 | ISO40 | ISO40 |
| Spindle Max Speed | r.p.m. | (ISO40)10,000rpm,(ISO50)6,000rpm | | |
| Drive Type | | Belt Driven | | |
| Spindle motor | kw | 5.5 | 7.5 | 11 |
| ATC | | | | |
| Tool Quantity | | 24Tools | 24Tools | 24Tools |
| Tool change type | | Arm Type | Arm Type | Arm Type |
| Max. tool diameter&length | mm | φ80/300 | φ80/300 | φ80/300 |
| Max. tool weight | kgs | 7 | 7 | 7 |
| Handle Type | | ISO40 (BT,CAT,DIN, HSK, SK) | | |
| Tool change time | | T-T:1.8 | T-T:1.8 | T-T:1.8 |
| MOTOR | | | | |
| Servo motor X/Y/Z axis-FANUC | kw | 1.8/1.8/1.8BS | 2.5/2.5/2.5 | 2.5/2.5/2.5 |
| Servo motor X/Y/Z axis-MITSUBISHI | kw | 2.0/2.0/3.0BS | 2.0/2.0/3.5BS | 2.0/2.0/3.5BS |
| 3-Axis cutting feed rate | mm/min | 12000 | 12000 | 12000 |
| 3-Axis rapid feed rate | M/min | 36/36/36 | 24/24/24(36) | 24/24/24(36) |
| OTHER | | | | |
| Machine Size | L*W*H(M) | 2270 x 3400 x 2300 mm | 2810 x 5570 x 3300 mm | 3660 x 5160 x 3300 mm |
| Machine Weight | kgs | 4000 | 6500 | 7500 |

STANDARD ACCESSORIES

| | |
|--|----------------------------------|
| Arm Type Automatic Tool Changer BT-40 (24-tools) | Rigid tapping |
| Fully Enclosed Guard | Tool Box |
| Swiveling Control Box | Leveling Screws & Blocks |
| Low Energy Work Light | Operation Manual |
| LED 3 Color Warning Light | Mechanical Oil Coolant Separator |
| Volumetric Type Automatic Lubricator | Air Gun |
| Coolant and Chip Flushing System | Screw Type Chip Conveyor |
| Auto Power Off | Chip Wash System |

OPTIONAL ACCESSORIES

| |
|--|
| Arm Type Automatic Tool Changer BT40 (32-Tools) |
| Chain Type Automatic Tool Changer BT40 (32/40-Tools) |
| Arm Type Automatic Tool Changer BT50 (24-Tools) |
| Chain Type Automatic Tool Changer BT50 (32-Tools) |
| Coolant Through Spindle (CTS) |
| Transformer |
| Chain Chip Conveyor |
| Linear Scale |
| CNC Rotary Table |
| Automatic Tool Probe |
| Automatic Tool Setter |
| Maple 2-Step Gear Box-BT40 (6000,8000,10000 rpm) |
| Maple 2-Step Gear Box-BT50 (6000,8000 rpm) |

Machine layout

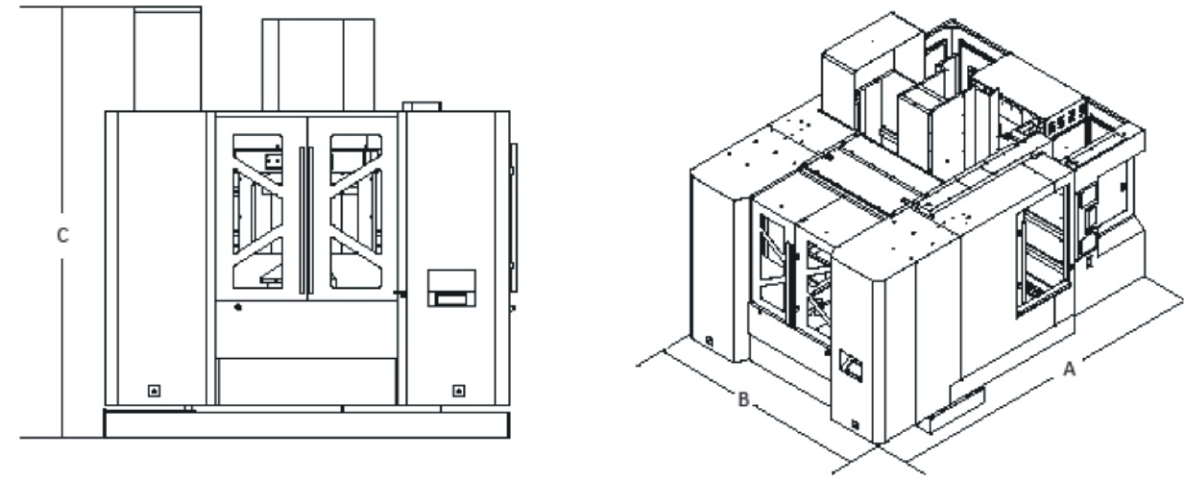

| M-One APC Series Machine Dimensions | | | |
|-------------------------------------|------------|------------|-------------|
| Series | M-One6 APC | M-One8 APC | M-One10 APC |
| Dimension A | 3200 mm | 3700 mm | 3700 mm |
| Dimension B | 2070 mm | 2270 mm | 2656 mm |
| Dimension C | 2720 mm | 2870 mm | 2870 mm |

Machine APC work table size and diagram

