

SPECIAL SPRINGS

氮氣彈簧

依<<彈簧鋼體直徑>>選取

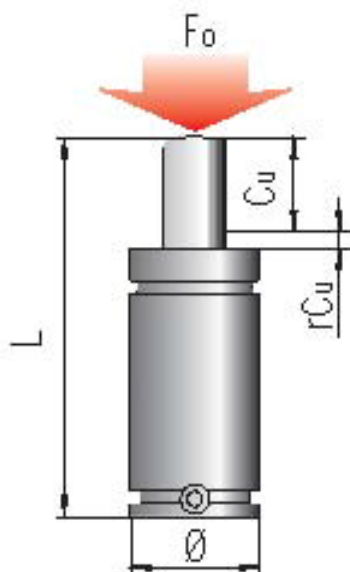

鋼體直徑	系列代號	初壓力	行程	保留安全行程	彈簧總長度
Ø mm		F ₀ daN	C _u mm	rC _u mm	L mm
M16 x 1.5	NE 16 x 1.5	2.8 - 42	10 - 125	1	65 - 295
M16 x 2	NE 16 x 2	2.8 - 42	10 - 125	1	65 - 295
19	M 90	5 - 90	7 - 125	1	56 - 295
19	MS 90	5 - 90	7 - 122	1	62 - 295
19	RV 170	170	7 - 125	1	44 - 285
19	RS 170	170	7 - 122	1	50 - 285
M24 x 1.5	NE 24 x 1.5	11 - 170	10 - 125	1	65 - 295
M24 x 1.5	M 90 TBM	5 - 90	7 - 125	-	56 - 295
M24 x 1.5	M 90 TEM	5 - 90	7 - 125	-	56 - 295
1" - 8 THD	M 90 TBI	5 - 90	7 - 125	-	56 - 295
25	M 200	17 - 200	7 - 125	1	56 - 295
25	MS 200	17 - 200	7 - 122	1	62 - 295
25	ML 300	310	10 - 80	2	75 - 220
25	RV 320	320	7 - 125	1	44 - 285
25	RS 320	320	7 - 122	1	50 - 285
25	KE 400	425	10 - 50	1	70 - 195
32	SC 150	170	10 - 125	2	70 - 300
32	H 300	300	10 - 125	2	70 - 300
32	RV 350	360	10 - 125	2	50 - 280
32	RS 350	360	7 - 122	2	50 - 280
32	ML 500	510	10 - 80	2	75 - 225

鋼體直徑		初壓力	行程	保留安全行程	彈簧總長度
Ø	系列代號	F ₀	Cu	rCu	L
mm		daN	mm	mm	mm
32	KE 750	740	6 - 50	1	63 - 195
38	SC 250	260	10 - 125	2	70 - 300
38	H 500	470	10 - 125	2	70 - 300
38	RV 500	470	10 - 125	2	50 - 280
38	RS 500	470	7 - 122	2	50 - 280
38	ML 1000	980	10 - 80	2	75 - 240
38	KE 1000	1060	6 - 50	1	61 - 230
M38 x 1.5	SCF 250	260	10 - 125	2	70 - 300
M38 x 1.5	HF 500	470	10 - 125	2	70 - 300
45	S 500	470	6 - 125	2	62 - 300
45	SC 500	470	13 - 160	2	110.4 - 405
45	H 700	680	13 - 160	2	110.4 - 405
45	RV 750	740	10 - 125	2	52 - 282
45	RS 750	740	7 - 122	2	52 - 282
45	RF 750	740	10 - 125	2	62 - 292
M45 x 1.5	SCF 500	470	13 - 160	2	110.4 - 405
M45 x 1.5	HF 700	680	13 - 160	2	110.4 - 405
50	S 750	740	6 - 125	3	62 - 300
50	SC 750	740	13 - 300	3	120.4 - 695
50	RV 1000	920	10 - 125	3	58 - 288
50	RS 1000	920	10 - 122	3	64 - 288
50	RF 1000	920	13 - 125	3	74 - 298
50	RV 1200	1060	10 - 125	3	58 - 288
50	RS 1200	1060	10 - 122	3	64 - 288
50	RF 1200	1060	13 - 125	3	74 - 298
50	H 1000	1060	13 - 300	3	120.4 - 695
50	KE 1800	1885	6 - 50	1	66 - 220
50	ML 1800	1925	15 - 80	3	95 - 245
M50 x 1.5	SCF 750	740	13 - 300	3	120.4 - 695
M50 x 1.5	HF 1000	1060	13 - 300	3	120.4 - 695
63	RV 1500	1530	10 - 125	3	64 - 294
63	RS 1500	1530	10 - 122	3	70 - 294
63	RF 1500	1530	13 - 125	3	80 - 304
63	KE 3000	2945	10 - 50	1	85 - 205
63	ML 3000	3180	15 - 80	3	100 - 250

鋼體直徑		初壓力	行程	保留安全行程	彈簧總長度
Ø	系列代號	F ₀	Cu	rCu	L
mm		daN	mm	mm	mm
75	S 1500	1530	25 - 100	3	110 - 260
75	SC 1500	1530	25 - 300	3	160 - 710
75	LS 1500	1590	25 - 300	3	160 - 710
75	H 2400	2385	25 - 300	3	160 - 710
75	LS 2400	2385	25 - 300	3	160 - 710
75	RV 2400	2385	10 - 125	3	65 - 295
75	RS 2400	2385	13 - 122	3	77 - 295
75	RF 2400	2385	16 - 125	3	87 - 305
75	KE 4700	4675	10 - 50	1	80 - 240
75	ML 4700	4925	15 - 80	3	100 - 250
95	LS 3000	2830	25 - 300	3	170 - 720
95	S 3000	2945	25 - 100	3	120 - 270
95	SC 3000	2945	25 - 300	3	170 - 720
95	H 4200	4240	25 - 300	3	170 - 720
95	LS 4200	4240	25 - 300	3	170 - 720
95	RV 4200	4240	16 - 125	3	90 - 308
95	RS 4200	4240	13 - 122	3	90 - 308
95	KE 7500	7540	10 - 50	1	90 - 255
95	ML 7500	7700	15 - 80	3	115 - 260
120	LS 5000	4418	25 - 300	3	190 - 740
120	SC 5000	4980	25 - 300	3	190 - 740
120	H 6600	6630	25 - 300	3	190 - 740
120	LS 6600	6630	25 - 300	3	190 - 740
120	RV 6600	6630	16 - 125	3	100 - 318
120	RS 6600	6630	13 - 122	3	100 - 318
120	KE 12000	11780	10 - 50	1	100 - 260
120	ML 12000	12720	15 - 80	3	115 - 265
150	SC 7500	7540	25 - 300	3	205 - 755
150	LS 7500	7630	25 - 300	3	205 - 755
150	LS 9500	9540	25 - 300	3	205 - 755
150	RV 9500	9540	19 - 125	3	116 - 328
150	RS 9500	9540	16 - 122	3	116 - 328
150	KE 18500	18410	10 - 50	1	110 - 270
195	SC 10000	10600	25 - 300	3	210 - 760
195	H 18500	18400	25 - 300	3	210 - 760

SPECIAL SPRINGS

氮 氣 彈 簧

依<<初壓力>>選取

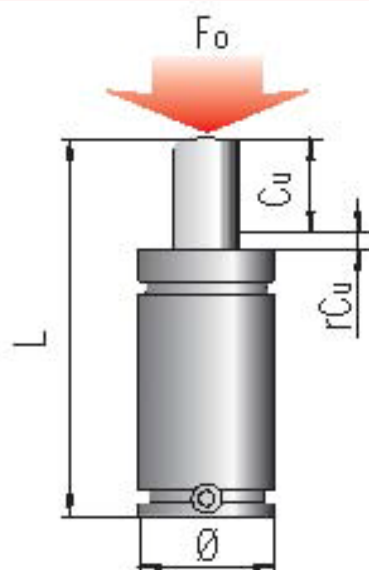

初壓力 F_0 daN	系列代號	鋼體直徑 \emptyset mm	行程 C_u mm	保留安全行程 rC_u mm	彈簧總長度 L mm
2.8 - 42	NE 16 x 1.5	M16 x 1.5	10 - 125	1	65 - 295
2.8 - 42	NE 16 x 2	M16 x 2	10 - 125	1	65 - 295
5 - 90	MS 90	19	7 - 122	1	62 - 295
5 - 90	M 90	19	7 - 125	1	56 - 295
5 - 90	M 90 TBM	M24 x 1.5	7 - 125	-	56 - 295
5 - 90	M 90 TBI	1" - 8 THD	7 - 125	-	56 - 295
5 - 90	M 90 TEM	M24 x 1.5	7 - 125	-	56 - 295
11 - 170	NE 24 x 1.5	M24 x 1.5	10 - 125	1	65 - 295
17 - 200	M 200	25	7 - 125	1	56 - 295
17 - 200	MS 200	25	7 - 122	1	62 - 295
170	RV 170	19	7 - 125	1	44 - 285
170	RS 170	19	7 - 122	1	50 - 285
170	SC 150	32	10 - 125	2	70 - 300
260	SC 250	38	10 - 125	2	70 - 300
260	SCF 250	M38 x 1.5	10 - 125	2	70 - 300
300	H 300	32	10 - 125	2	70 - 300
310	ML 300	25	10 - 80	2	75 - 220
320	RV 320	25	7 - 125	1	44 - 285
320	RS 320	25	7 - 122	1	50 - 285
360	RV 350	32	10 - 125	2	50 - 280
360	RS 350	32	7 - 122	2	50 - 280

初壓力		鋼體直徑	行程	保留安全行程	彈簧總長度
F ₀	系列代號	∅	Cu	rCu	L
daN		mm	mm	mm	mm
425	KE 400	25	10 - 50	1	70 - 195
470	H 500	38	10 - 125	2	70 - 300
470	RV 500	38	10 - 125	2	50 - 280
470	RS 500	38	7 - 122	2	50 - 280
470	HF 500	M38 x 1.5	10 - 125	2	70 - 300
470	S 500	45	6 - 125	2	62 - 300
470	SC 500	45	13 - 160	2	110.4 - 405
470	SCF 500	M45 x 1.5	13 - 160	2	110.4 - 405
510	ML 500	32	10 - 80	2	75 - 225
680	H 700	45	13 - 160	2	110.4 - 405
680	HF 700	M45 x 1.5	13 - 160	2	110.4 - 405
740	KE 750	32	6 - 50	1	63 - 195
740	RV 750	45	10 - 125	2	52 - 282
740	RS 750	45	7 - 122	2	52 - 282
740	RF 750	45	10 - 125	2	62 - 292
740	S 750	50	6 - 125	3	62 - 300
740	SC 750	50	13 - 300	3	120.4 - 695
740	SCF 750	M50 x 1.5	13 - 300	3	120.4 - 695
920	RV 1000	50	10 - 125	3	58 - 288
920	RS 1000	50	10 - 122	3	64 - 288
920	RF 1000	50	13 - 125	3	74 - 298
980	ML 1000	38	10 - 80	2	75 - 240
1060	KE 1000	38	6 - 50	1	61 - 230
1060	RV 1200	50	10 - 125	3	58 - 288
1060	RS 1200	50	10 - 122	3	64 - 288
1060	RF 1200	50	13 - 125	3	74 - 298
1060	H 1000	50	13 - 300	3	120.4 - 695
1060	HF 1000	M50 x 1.5	13 - 300	3	120.4 - 695
1530	RV 1500	63	10 - 125	3	64 - 294
1530	RS 1500	63	10 - 122	3	70 - 294
1530	RF 1500	63	13 - 125	3	80 - 304
1530	S 1500	75	25 - 100	3	110 - 260
1530	SC 1500	75	25 - 300	3	160 - 710
1590	LS 1500	75	25 - 300	3	160 - 710
1885	KE 1800	50	6 - 50	1	66 - 220
1925	ML 1800	50	15 - 80	3	95 - 245

初壓力		鋼體直徑	行程	保留安全行程	彈簧總長度
F ₀	系列代號	∅	Cu	rCu	L
daN		mm	mm	mm	mm
2385	H 2400	75	25 - 300	3	160 - 710
2385	LS 2400	75	25 - 300	3	160 - 710
2385	RV 2400	75	10 - 125	3	65 - 295
2385	RS 2400	75	13 - 122	3	77 - 295
2385	RF 2400	75	16 - 125	3	87 - 305
2830	LS 3000	95	25 - 300	3	170 - 720
2945	KE 3000	63	10 - 50	1	85 - 205
2945	S 3000	95	25 - 100	3	120 - 270
2945	SC 3000	95	25 - 300	3	170 - 720
3180	ML 3000	63	15 - 80	3	100 - 250
4240	H 4200	95	25 - 300	3	170 - 720
4240	LS 4200	95	25 - 300	3	170 - 720
4240	RV 4200	95	16 - 125	3	90 - 308
4240	RS 4200	95	13 - 122	3	90 - 308
4418	LS 5000	120	25 - 300	3	190 - 740
4675	KE 4700	75	10 - 50	1	80 - 240
4925	ML 4700	75	15 - 80	3	100 - 250
4980	SC 5000	120	25 - 300	3	190 - 740
6630	H 6600	120	25 - 300	3	190 - 740
6630	LS 6600	120	25 - 300	3	190 - 740
6630	RV 6600	120	16 - 125	3	100 - 318
6630	RS 6600	120	13 - 122	3	100 - 318
7540	KE 7500	95	10 - 50	1	90 - 255
7540	SC 7500	150	25 - 300	3	205 - 755
7630	LS 7500	150	25 - 300	3	205 - 755
7700	ML 7500	95	15 - 80	3	115 - 260
9540	LS 9500	150	25 - 300	3	205 - 755
9540	RV 9500	150	19 - 125	3	116 - 328
9540	RS 9500	150	16 - 122	3	116 - 328
10600	SC 10000	195	25 - 300	3	210 - 760
11780	KE 12000	120	10 - 50	1	100 - 260
12720	ML 12000	120	15 - 80	3	115 - 265
18400	H 18500	195	25 - 300	3	210 - 760
18410	KE 18500	150	10 - 50	1	110 - 270