



Anniversary Years
Towards a new future



Quick/Safe/Strong/Powerful

SL-656A Capacity: 4.0tons

THIN TYPE WHEEL ALIGNMENT LIFT



SGS

CE

www.carleo.com.tw



● Safety Locks Device



● Extension Plate



● Fine View

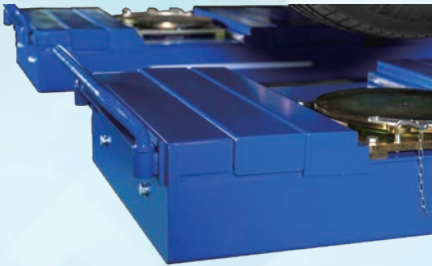

● Front Wheel Stopper

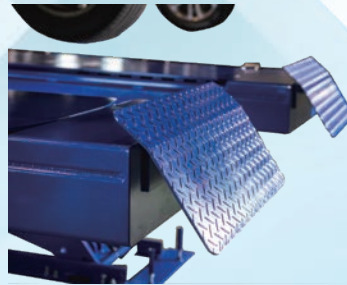

● Rear wheel stopper



● Lock Pin

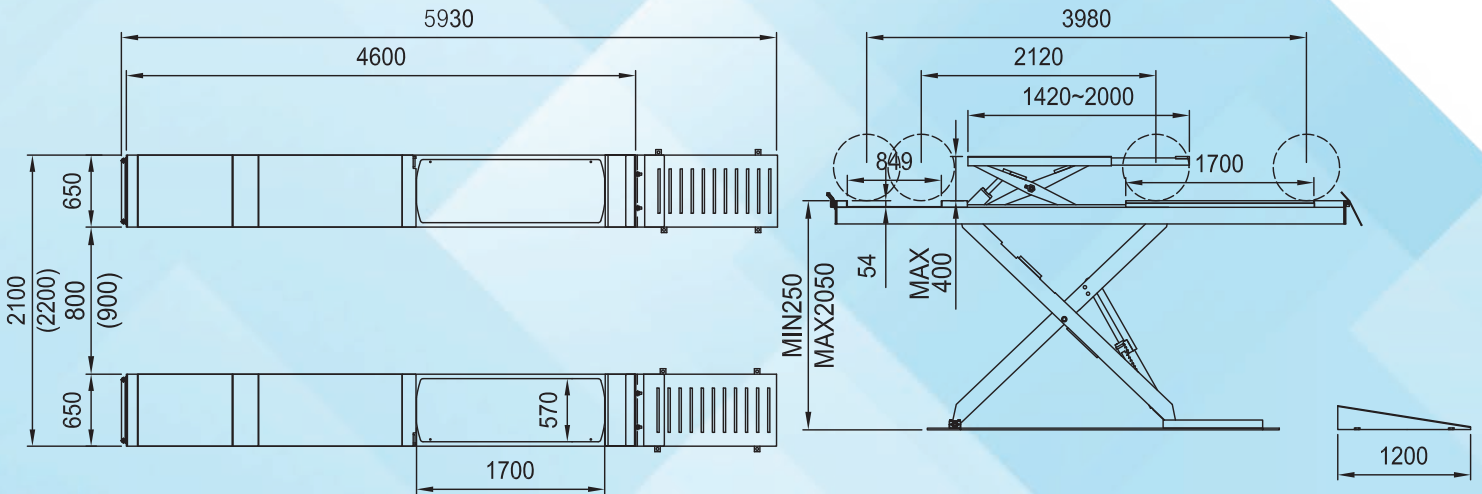

MODEL	MAX LOADING WEIGHT	LIFTING HEIGHT	HORSEPOWER	VOLTAGE	AIR PRESSURE	LIFTING TIME	OPERATION	CONTROL
SL-656A	Upper 3000Kg Lower 4000Kg	Upper 400 m/m Lower 1800 m/m	2HP	AC 220 50HZ AC 380 60HZ	5~8kg/cm ²	Upper about 13 sec Lower about 45 sec	Hydraulic	Electric

CARLEO GROUP

Ming Lurn Precision Machine Co.,LTD
Hsieh Lurn Precision Machine Co.,LTD

TEL:+886-4-2699-6655 FAX:+886-4-2699-0939
E-mail: lift@carleo.com.tw ◆ http:// www.carleo.com.tw

Head Factory : No.66,Lane 2,Sec.2, Shatian Rd, Dadu District,
Taichung, 43244 Taiwan
Taichung Factory : No.2,30th Rd.,Industrial Park,
Taichung, 40768 Taiwan