

VERTICAL TURRET MILLING MACHINE

EUMEGA BED TYPE MILLING MACHINE
CNC BED TYPE MILLING MACHINE
VERTICAL MILLING CENTER

VERTICAL TURRET MILLING MACHINE

BED TYPE MILLING MACHINE
CNC BED TYPE MILLING MACHINE
VERTICAL MILLING CENTER



VERTICAL TURRET MILLING MACHINE
VERTICAL MILLING CENTER
CNC BED TYPE MILLING MACHINE
BED TYPE MILLING MACHINE

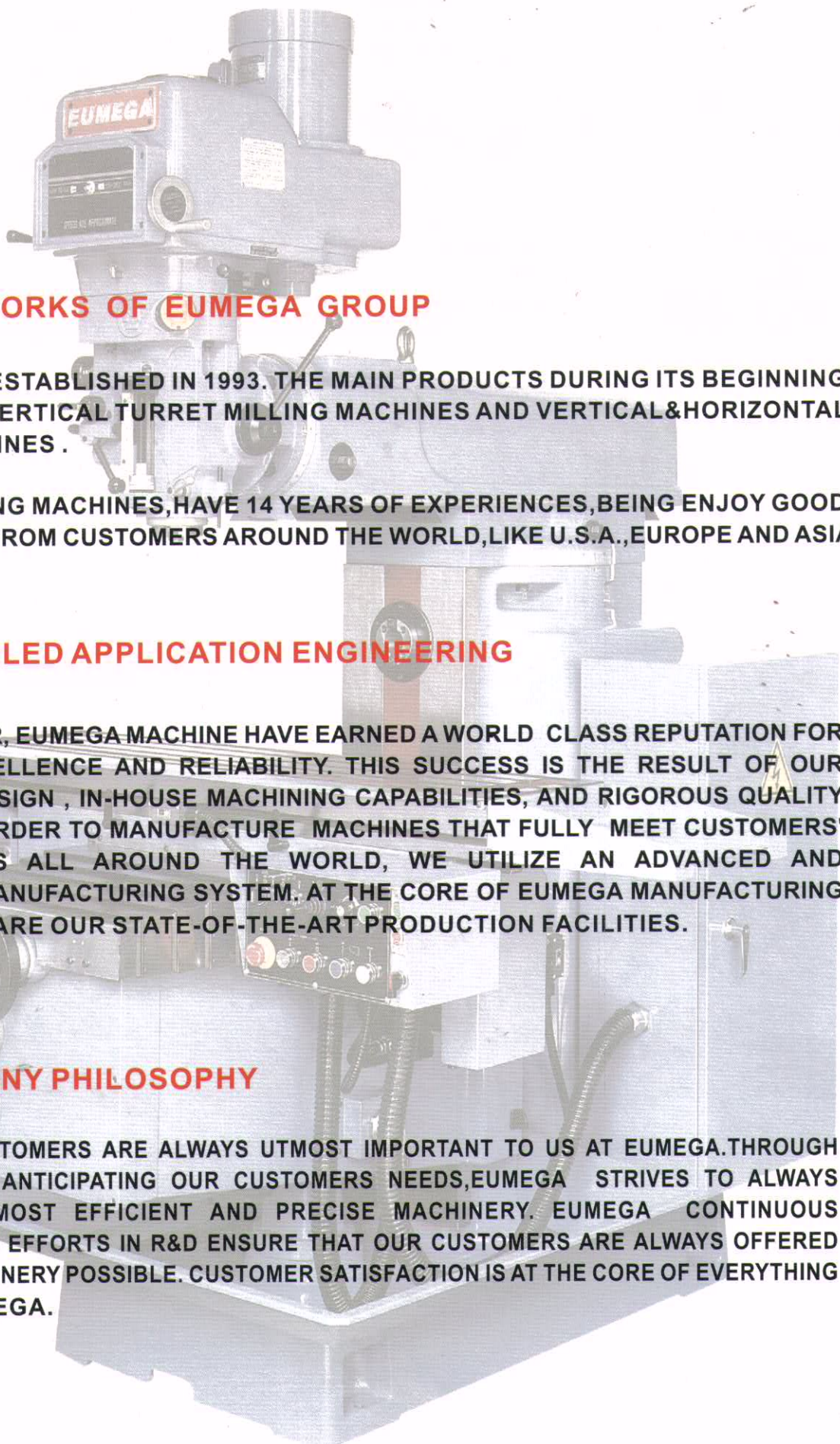

MACHINE WORKS OF EUMEGA GROUP

EUMEGA WAS ESTABLISHED IN 1993. THE MAIN PRODUCTS DURING ITS BEGINNING STAGE WERE VERTICAL TURRET MILLING MACHINES AND VERTICAL&HORIZONTAL MILLING MACHINES .

EUMEGA MILLING MACHINES, HAVE 14 YEARS OF EXPERIENCES, BEING ENJOY GOOD REPUTATIONS FROM CUSTOMERS AROUND THE WORLD, LIKE U.S.A., EUROPE AND ASIA ETC.

UNPARALLELED APPLICATION ENGINEERING

OVER THE YEAR, EUMEGA MACHINE HAVE EARNED A WORLD CLASS REPUTATION FOR PRODUCT EXCELLENCE AND RELIABILITY. THIS SUCCESS IS THE RESULT OF OUR INNOVATIVE DESIGN , IN-HOUSE MACHINING CAPABILITIES, AND RIGOROUS QUALITY CONTROL. IN ORDER TO MANUFACTURE MACHINES THAT FULLY MEET CUSTOMERS' REQUIREMENTS ALL AROUND THE WORLD, WE UTILIZE AN ADVANCED AND INTEGRATED MANUFACTURING SYSTEM. AT THE CORE OF EUMEGA MANUFACTURING CAPABILITIES ARE OUR STATE-OF-THE-ART PRODUCTION FACILITIES.

OUR COMPANY PHILOSOPHY

SATISFYING CUSTOMERS ARE ALWAYS UTMOST IMPORTANT TO US AT EUMEGA. THROUGH LISTENING AND ANTICIPATING OUR CUSTOMERS NEEDS, EUMEGA STRIVES TO ALWAYS PROVIDE THE MOST EFFICIENT AND PRECISE MACHINERY. EUMEGA CONTINUOUS BREAKTHROUGH EFFORTS IN R&D ENSURE THAT OUR CUSTOMERS ARE ALWAYS OFFERED THE BEST MACHINERY POSSIBLE. CUSTOMER SATISFACTION IS AT THE CORE OF EVERYTHING WE DO AT EUMEGA.

BED TYPE MILLING MACHINE
CNC BED TYPE MILLING MACHINE
VERTICAL MILLING CENTER

EUMEGA MACHINERY WORKS CO., LTD

Photo shows may include some options

規格表 Specifications

單位 UNIT: INCH(MM)

機型 MODEL	MDV-2	MD-2
工作台尺寸 Table Size	9x42 in (229x1067 mm) 9x49 in (229x1245 mm) OPT	
T型槽(寬度x數量x間距) T-SLOTS(WxNOXD)	5/8x3x2 1/2 in (16 * 3 * 63.5 mm)	
左右行程 Longitudinal Travel	手動 Maunal	30 in (762 mm)
	自動 Power Feed	26.5 in (673 mm)
前後行程 Cross Travel	12 in (305 mm)	
上下行程 Vertical Knee	16 in (406 mm)	
伸臂行程 Ram Travel	12 in (305 mm)	
主軸錐度 Spindle Taper	R8 or ISO #30 (ISO #40 OPT)	
主軸升降套行程 Spindle Quill Travel	5 in (127 mm)	
主軸馬達 Spindle Motor	2.2KW (3HP)	1.5KW (2HP)
變速方式 Change Of Speed	無段變速 Variable Speed	8段變速 8 Step Speed
主軸迴轉速度 Spindle Speed R.P.M.	60-4200 rpm	80-2720 rpm
主軸每轉進刀速率 Quill Power Feed Rate	0.0015,0.003,0.006 in (0.04,0.08,0.15 mm)	
頭部旋轉角度 Headstock Swivel&Incline	R & L 90° F & B 45°	
機械淨重 Machine Net Weight	1000 kgs	

*本公司保有變更設計之權利，如有更改不另行通知。
 Specifications subject to change without prior notice.
 * "OPT"指特殊選購配件。
 "OPT" means optional accessories.

MDV-2

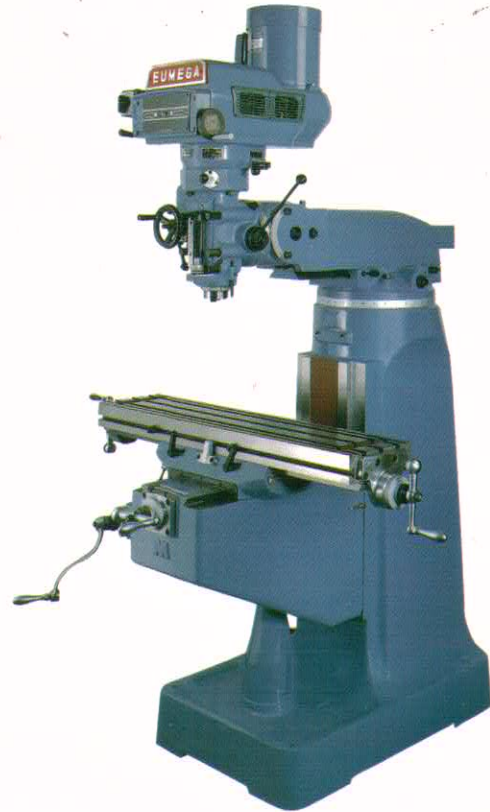

規格表 Specifications

單位 UNIT: INCH(MM)

機型 MODEL	MDV-3	MD-3
工作台尺寸 Table Size	10x50 in (254x1270 mm) 10x54 in (254x1371 mm) OPT	
T型槽(寬度x數量x間距) T-SLOTS(WxNOXD)	5/8x3x2 1/2 in (16 * 3 * 63.5mm)	
左右行程 Longitudinal Travel	手動 Maunal	36 in (914 mm)
	自動 Power Feed	32.5 in (825 mm)
前後行程 Cross Travel	15.75 in (400 mm)	
上下行程 Vertical Knee Travel	16 in (406 mm)	
伸臂行程 Ram Travel	24 in (610 mm)	
主軸錐度 Spindle Taper	R8 or ISO #30 (ISO #40 OPT)	
主軸升降套行程 Spindle Quill Travel	5 in (127 mm)	
主軸馬達 Spindle Motor	2.2KW (3HP)	1.5KW (2HP)
變速方式 Change Of Speed	無段變速 Variable Speed	8段變速 8 Step Speed
主軸迴轉速度 Spindle Speed R.P.M.	60-4200 rpm	80-2720rpm
主軸每轉進刀速率 Quill Power Feed Rate	0.0015,0.003,0.006 in (0.04,0.08,0.15 mm)	
頭部旋轉角度 Headstock Swivel&Incline	R & L 90° F & B 45°	
機械淨重 Machine Net Weight	1200 kgs	

*本公司保有變更設計之權利，如有更改不另行通知。
 Specifications subject to change without prior notice.
 * "OPT"指特殊選購配件。
 "OPT" means optional accessories.

MDV-3

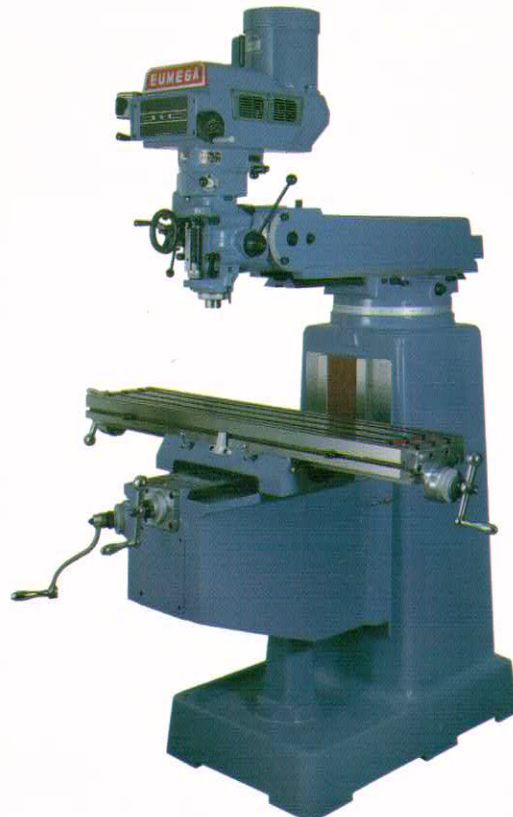

BED TYPE MILLING MACHINE
 CNC BED TYPE MILLING MACHINE
 VERTICAL MILLING CENTER

EUMEGA MACHINERY WORKS CO., LTD

Photo shows may include some options.

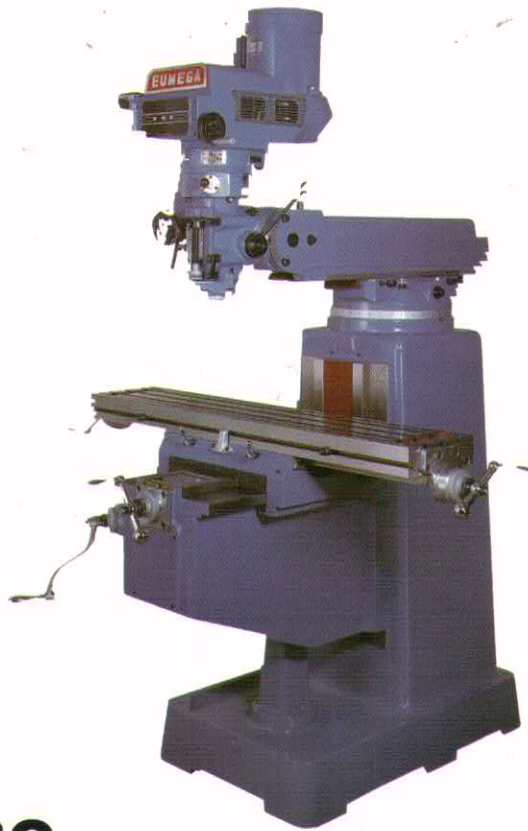

規格表 Specifications

單位 UNIT: INCH(MM)

機型 MODEL	MDV-3Q	MD-3Q
工作台尺寸 Table Size	10x50 in (254x1270 mm) 10x54 in (254x1371 mm) OPT 11x52 in (279x1320 mm) OPT	
T型槽 (寬度x數量x間距) T-SLOTS(WxNOXD)	5/8x3x2 1/2 in (16 * 3 * 63.5 mm)	
左右行程 Longitudinal Travel	手動 Maunal	36 in (914 mm)
	自動 Power Feed	32.5 in (825 mm)
前後行程 Cross Travel	15.75 in (400 mm)	
上下行程 Vertical Knee Travel	16 in (406 mm)	
伸臂行程 Ram Travel	24 in (610 mm)	
主軸升降套行程 Spindle Quill Travel	5 in (127 mm)	
主軸錐度 Spindle Taper	R8 or ISO #30 or (ISO #40 OPT)	
主軸馬達 Spindle Motor	2.2KW (3HP)	1.5KW (2HP)
變速方式 Change Of Speed	無段變速 Variable Speed	8段變速 8 Step Speed
主軸迴轉速度 Spindle Speed R.P.M.	60-4200rpm	80-2720rpm
主軸每轉進刀速率 Quill Power Feed Rate	0.0015,0.003,0.006 in (0.04,0.08,0.15 mm)	
頭部旋轉角度 Headstock Swivel&Incline	R & L 90° F & B 45°	
機械淨重 Machine Net Weight	1200 kgs	

*本公司保有變更設計之權利，如有更改不另行通知。
 Specifications subject to change without prior notice.
 * "OPT"指特殊選購配件。
 "OPT" means optional accessories.

MDV-3Q

規格表 Specifications

單位 UNIT: INCH(MM)

機型 MODEL	MDV-4	MD-4
工作台尺寸 Table Size	10x50 in (254x1270 mm) 10x54 in (254x1371 mm) OPT 11x52 in (279x1320 mm) OPT	
T型槽 (寬度x數量x間距) T-SLOTS(WxNOXD)	5/8x3x2 1/2 in (16 * 3 * 63.5 mm)	
左右行程 Longitudinal Travel	手動 Maunal	36 in (914 mm)
	自動 Power Feed	32 1/2 in (825 mm)
前後行程 Cross Travel	15.75 in (400 mm)	
上下行程 Vertical Knee Travel	16 in (406 mm)	
伸臂行程 Ram Travel	24 in (610 mm)	
主軸錐度 Spindle Taper	R8 or ISO #30 or (ISO #40 OPT)	
主軸升降套行程 Spindle Quill Travel	5 in (127 mm)	
主軸馬達 Spindle Motor	2.2KW (3HP)	1.5KW (2HP)
變速方式 Change Of Speed	無段變速 Variable Speed	8段變速 8 Step Speed
主軸迴轉速度 Spindle Speed R.P.M.	60-4200 rpm	80-2720 rpm
主軸每轉進刀速率 Quill Power Feed Rate	0.0015,0.003,0.006 in (0.04,0.08,0.15 mm)	
頭部旋轉角度 Headstock Swivel&Incline	R & L 90° F & B 45°	
機械淨重 Machine Net Weight	1350 kgs	

*本公司保有變更設計之權利，如有更改不另行通知。
 Specifications subject to change without prior notice.
 * "OPT"指特殊選購配件。
 "OPT" means optional accessories.

MDV-4

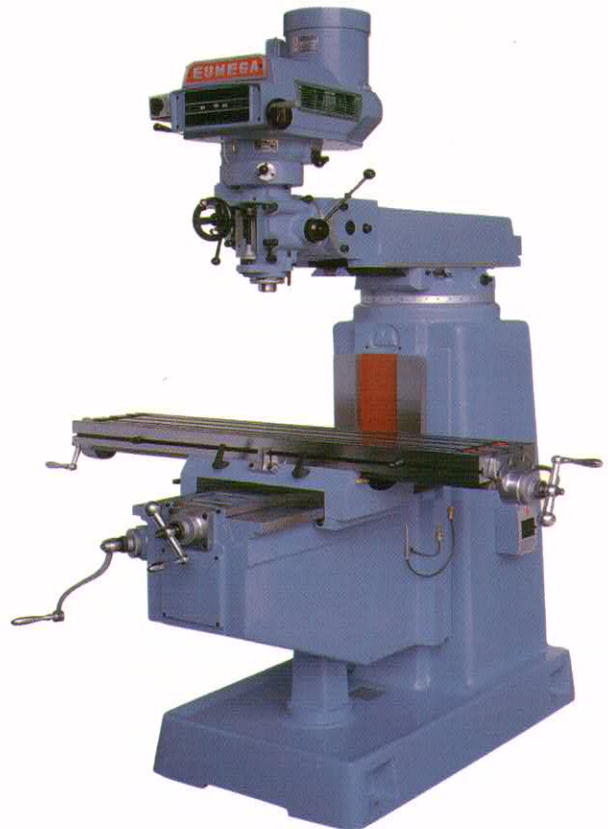

BED TYPE MILLING MACHINE
 CNC BED TYPE MILLING MACHINE
 VERTICAL MILLING CENTER

EUMEGA MACHINERY WORKS CO., LTD

Photo shows may include some options.

規格表 Specifications

單位 UNIT: INCH(MM)

機型 MODEL	MDV-4S	MD-4S
工作台尺寸 Table Size	10x50 in (254x1270 mm) 10x54 in (254x1371 in) OPT 11x52 in (279x1320 mm) OPT	
T型槽(寬度x數量x間距) T-SLOTS(WxNOXD)	5/8x3x2 2/1 in (16" 3" 63.5mm)	
左右行程 Longitudinal Travel	手動 Manual	36 in (914 mm)
	自動 Power Feed	32.5 in (825 mm)
前後行程 Cross Travel	16 in (400 mm)	
上下行程 Vertical Knee Travel	16 in (406 mm)	
伸臂行程 Ram Travel	24 in (610 mm)	
主軸錐度 Spindle Taper	ISO #40	
主軸升降套行程 Spindle Quill Travel	5 in (127mm)	
主軸馬達 Spindle Motor	3.75KW (5HP)	2.2KW (3HP)
變速方式 Change Of Speed	無段變速 Variable Speed	10段變速 10 Step Speed
主軸迴轉速度 Spindle Speed R.P.M.	70~3900rpm	73~3925 rpm
主軸每轉進刀速率 Quill Power Feed Rate	0.0015, 0.003, 0.006 in (0.04, 0.08, 0.15 mm)	
頭部旋轉角度 Headstock Swivel&Incl	R & L 90°、F & B 45°	
機械淨重 Machine Net Weight	1350 kgs	

*本公司保有變更設計之權利，如有更改不另行通知。

Specifications subject to change without prior notice.

*"OPT"指特殊選購配件。

"OPT" means optional accessories.

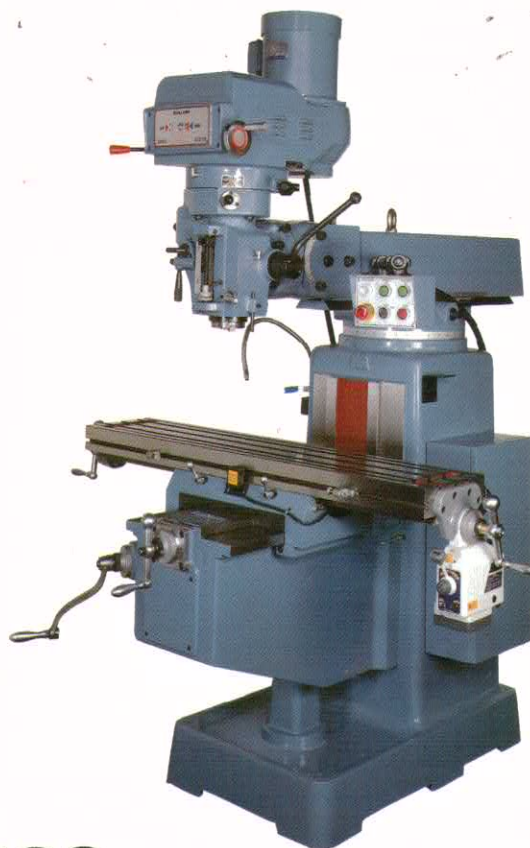

MDV-3QS

規格表 Specifications

單位 UNIT: INCH(MM)

機型 MODEL	MDV-4.5	MD-4.5
工作台尺寸 Table Size	10x50 in (254x1270 mm) 10x54 in (254x1371 in) OPT 11x52 in (279x1320 mm) OPT	
T型槽(寬度x數量x間距) T-SLOTS(WxNOXD)	5/8x3x2 2/1 in (16" 3" 63.5mm)	
左右行程 Longitudinal Travel	手動 Manual	36 in (914 mm)
	自動 Power Feed	32.5 in (825 mm)
前後行程 Cross Travel	16 in (406 mm)	
上下行程 Vertical Knee Travel	18 in (450 mm)	
伸臂行程 Ram Travel	24 in (610 mm)	
主軸錐度 Spindle Taper	ISO #40	
主軸升降套行程 Spindle Quill Travel	5.5 in (140 mm)	
主軸馬達 Spindle Motor	3.75KW (5HP)	2.2KW (3HP)
變速方式 Change Of Speed	無段變速 Variable Speed	10段變速 10 Step Speed
主軸迴轉速度 Spindle Speed R.P.M.	80-3800 rpm	80-3450 rpm
主軸每轉進刀速率 Quill Power Feed Rate	0.0015, 0.003, 0.006 in (0.04, 0.08, 0.15 mm)	
頭部旋轉角度 Headstock Swivel&Incl	R & L 90°	
機械淨重 Machine Net Weight	1700 kgs	

*本公司保有變更設計之權利，如有更改不另行通知。

Specifications subject to change without prior notice.

*"OPT"指特殊選購配件。

"OPT" means optional accessories.

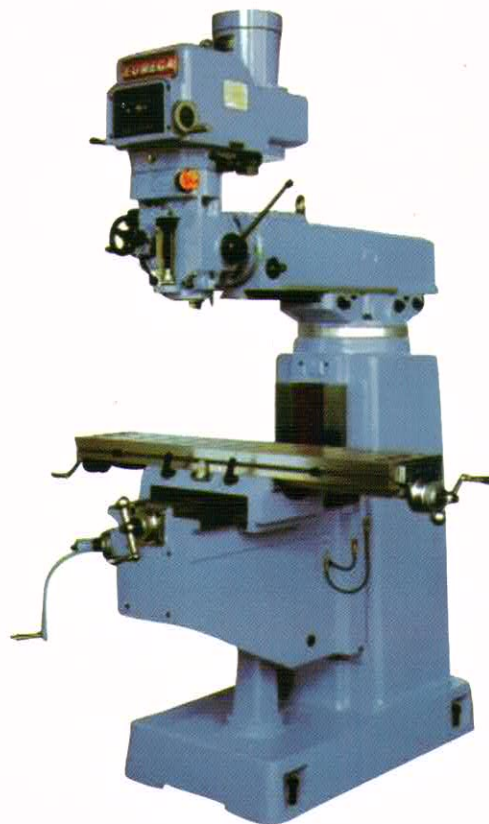

MDV-4.5

BED TYPE MILLING MACHINE
 CNC BED TYPE MILLING MACHINE
 VERTICAL MILLING CENTER

EUMEGA MACHINERY WORKS CO., LTD

Photo shows may include some options.

規格表 Specifications

單位 UNIT: INCH(MM)

機型 MODEL	MDV-5SR	MD-5SR
工作台尺寸 Table Size	12x50 in (305x1270 mm) 12x60 in (305x1524 mm) OPT	
T型槽(寬度x數量x間距) T-SLOTS(WxNOXD)	18x3x63.5mm	
左右行程 Longitudinal Travel	31.5 in (800mm) 39.4 in (1000 mm) OPT	
前後行程 Cross Travel	18.89 in (480 mm)	
上下行程 Vertical Knee Travel	20 in (520 mm)	
伸臂行程 Ram Travel	24 in (610 mm)	
主軸錐度 Spindle Taper	ISO #40	
主軸升降行程 Spindle Quill Travel	5.5 in (140 mm)	
主軸馬達 Spindle Motor	3.7KW (5HP)	2.2KW (3HP)
變速方式 Change Of Speed	無段變速 Variable Speed	10段變速 10 Step Speed
主軸迴轉速度 Spindle Speed R.P.M.	70-3800rpm	80-3450rpm
主軸每轉進刀速率 Quill Power Feed Rate	0.0015,0.003,0.006 in (0.04,0.08,0.15 mm)	
頭部旋轉角度 Headstock Swivel&Incl	R & L 90°	
機械淨重 Machine Net Weight	2200 kgs	

*本公司保有變更設計之權利，如有更改不另行通知。
 Specifications subject to change without prior notice.
 * "OPT"指特殊選購配件。
 "OPT" means optional accessories.

MDV-5SR

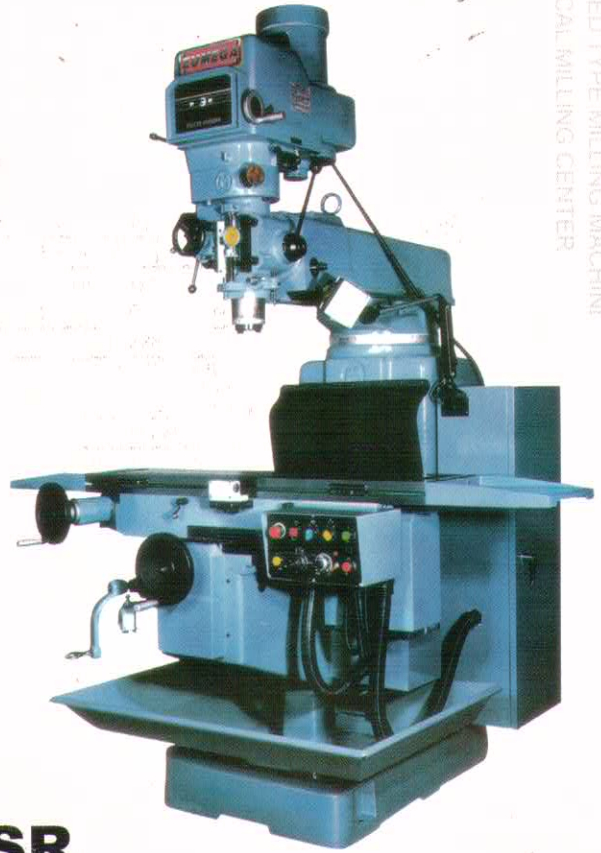

規格表 Specifications

單位 UNIT: INCH(MM)

機型 MODEL	MDV-6SR	MD-6SR
工作台尺寸 Table Size	12x50 in (305x1270 mm) 12x60 in (305x1524 mm) OPT	
T型槽(寬度x數量x間距) T-SLOTS(WxNOXD)	18x3x63.5mm	
左右行程 Longitudinal Travel	31.5 in (800 mm) 39.3 in (1000 mm) OPT 47.2 in (1200 mm) OPT	
前後行程 Cross Travel	18 in (460 mm)	
上下行程 Vertical Knee Travel	19.69 in (500 mm)	
伸臂行程 Ram Travel	24 in (610 mm)	
主軸錐度 Spindle Taper	ISO #40	
主軸升降行程 Spindle Quill Travel	5.5 in (140 mm)	
主軸馬達 Spindle Motor	3.7KW (5HP)	2.2KW (3HP)
變速方式 Change Of Speed	無段變速 Variable Speed	10段變速 10 Step Speed
主軸迴轉速度 Spindle Speed R.P.M.	70-3800rpm	80-3450rpm
主軸每轉進刀速率 Quill Power Feed Rate	0.0015,0.003,0.006 in (0.04,0.08,0.15 mm)	
頭部旋轉角度 Headstock Swivel&Incl	R & L 90°	
機械淨重 Machine Net Weight	2600 kgs	

*本公司保有變更設計之權利，如有更改不另行通知。
 Specifications subject to change without prior notice.
 * "OPT"指特殊選購配件。
 "OPT" means optional accessories.

MDV-6SR

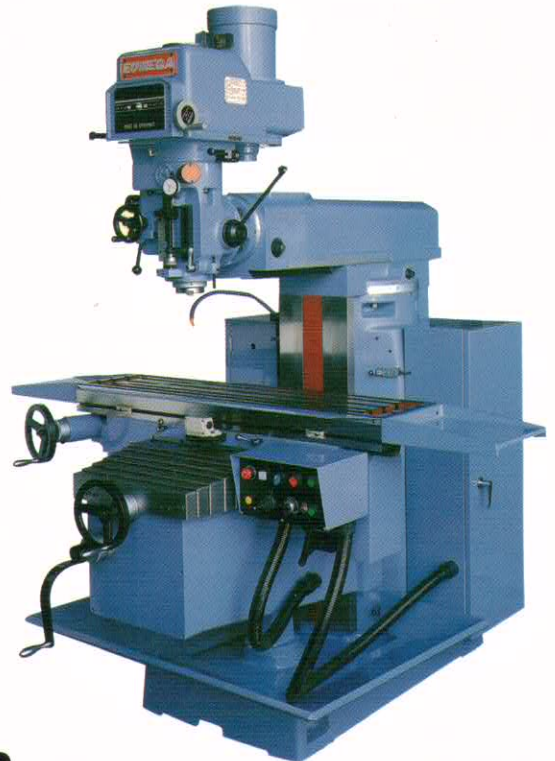

BED TYPE MILLING MACHINE
 CNC BED TYPE MILLING MACHINE
 VERTICAL MILLING CENTER

EUMEGA MACHINERY WORKS CO., LTD

Photo shows may include some options.

規格表 Specifications

單位 UNIT: INCH(MM)

機型 MODEL	MDV-6SRH	MD-6SRH
工作台尺寸 Table Size	12x50 in (305x1270 mm) 12x60 in (305x1524 mm) OPT	
T型槽(寬度x數量x間距) T-SLOTS(WxNOXD)	18x3x63.5mm	
左右行程 Longitudinal Travel	31.5 in (800 mm) 39.4 in (1000 mm) OPT 47.2 in (1200 mm) OPT	
前後行程 Cross Travel	18 in (460 mm)	
上下行程 Vertical Knee Travel	19.69 in (500 mm)	
伸臂行程 Ram Travel	24 in (610 mm)	
主軸錐度 Spindle Taper	ISO #40	
主軸升降套行程 Spindle Quill Travel	5.5 in (140 mm)	
主軸馬達 Spindle Motor	3.75KW (5HP)	2.2KW (3HP)
變速方式 Change Of Speed	無段變速 Variable Speed	10段變速 10 Step Speed
主軸迴轉速度 Spindle Speed R.P.M.	70-3800rpm	80-3450rpm
主軸每轉進刀速率 Quill Power Feed Rate	0.0015,0.003,0.006 in (0.04,0.08,0.15 mm)	
頭部旋轉角度 Headstock Swivel&Incl	R & L 90°	
機械淨重 Machine Net Weight	2600 kgs	

*本公司保有變更設計之權利，如有更改不另行通知。
 Specifications subject to change without prior notice.
 * "OPT"指特殊選購配件。
 "OPT" means optional accessories.

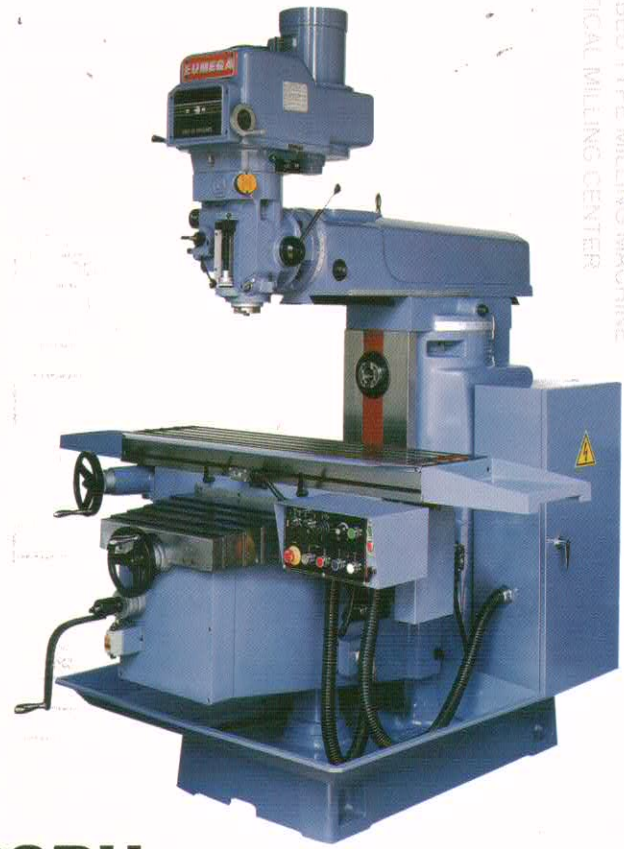

MDV-6SRH

規格表 Specifications

單位 UNIT: INCH(MM)

機型 MODEL	MDBI-6SRH	MDB-6SRH
工作台尺寸 Table Size	12x50 in (305x1270 mm) 12x60 in (305x1524 mm) OPT	
T型槽(寬度x數量x間距) T-SLOTS(WxNOXD)	18x3x63.5mm	
左右行程 Longitudinal Travel	31.5 in (800 mm) 39.3 in (1000 mm) OPT 47.2 in (1200 mm) OPT	
前後行程 Cross Travel	18.9 in (460 mm)	
上下行程 Vertical Knee Travel	19.69 in (500 mm)	
伸臂行程 Ram Travel	24 in (610 mm)	
主軸錐度 Spindle Taper	ISO #40	
主軸升降套行程 Spindle Quill Travel	5.5 in (140 mm)	
主軸馬達 Spindle Motor	3.7KW (5HP)	2.2KW (3HP)
變速方式 Change Of Speed	無段變速 Variable Speed	16段變速 16 Step Speed
主軸迴轉速度 Spindle Speed R.P.M.	60-3600rpm	60-3600rpm
主軸每轉進刀速率 Quill Power Feed Rate	0.0015,0.003,0.006 in (0.04,0.08,0.15 mm)	
頭部旋轉角度 Headstock Swivel&Incl	R & L 90°	
機械淨重 Machine Net Weight	2600 kgs	

*本公司保有變更設計之權利，如有更改不另行通知。
 Specifications subject to change without prior notice.
 * "OPT"指特殊選購配件。
 "OPT" means optional accessories.

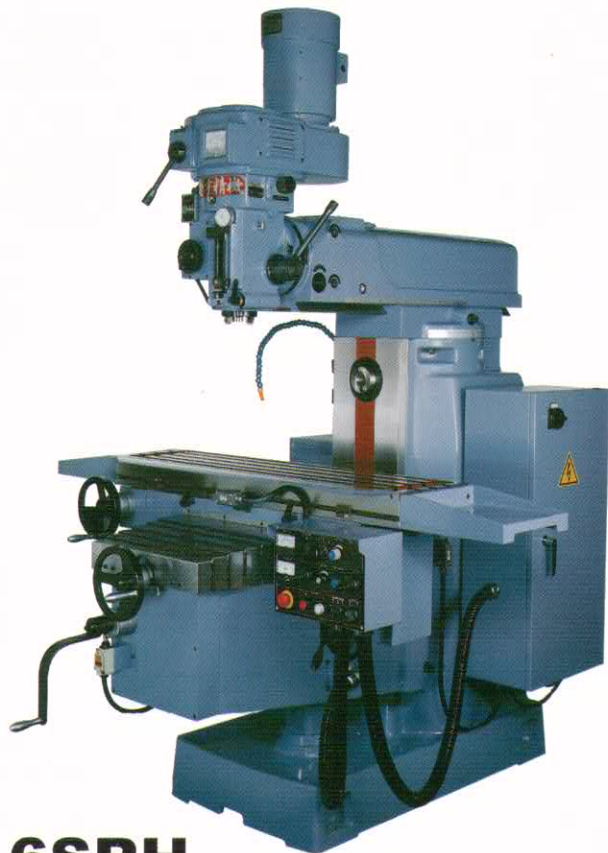

MDBI-6SRH

BED TYPE MILLING MACHINE
 CNC BED TYPE MILLING MACHINE
 VERTICAL MILLING CENTER

EUMEGA MACHINERY WORKS CO., LTD

Photo shows may include some options.

規格表 Specifications

單位 UNIT: INCH(MM)

機型 MODEL	KM (V)800 CNC FRAME	
工作台尺寸 Table Size	12x50 in (305x1270 mm) 12x60 in (305x1524 mm) OPT	
T型槽(寬度x數量x間距) T-SLOTS(WxNOXD)	18x3x63.5mm	
左右行程 Longitudinal Travel	31.5 in (800mm) 39.4 in (1000mm) OPT	
前後行程 Cross Travel	15.7 in (400 mm)	
上下行程 Vertical Knee Travel	16.9 in (430 mm)	
伸臂行程 Ram Travel	24 in (610 mm)	
主軸錐度 Spindle Taper	ISO #40	
主軸升降套行程 Spindle Quill Travel	5.5 in (140 mm)	
主軸馬達 Spindle Motor	3.7KW (5HP)	2.2KW (3HP)
變速方式 Change Of Speed	無段變速 Variable Speed	10段變速 10 Step Speed
主軸迴轉速度 Spindle Speed R.P.M.	70-3800 rpm	80-3500 rpm
機械淨重 Machine Net Weight	2000 kgs	

*本公司保有變更設計之權利，如有更改不另行通知。
 Specifications subject to change without prior notice.
 * "OPT"指特殊選購配件。
 "OPT" means optional accessories.

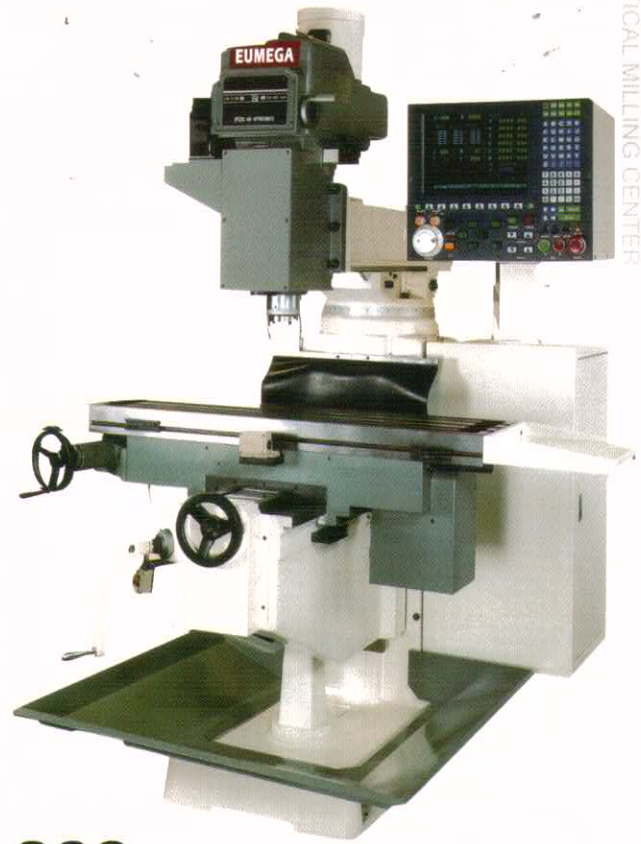

KMV-800

規格表 Specifications

單位 UNIT: INCH(MM)

機型 MODEL	BDV-6	BD-6
工作台尺寸 Table Size	12x60 in (305x1524 mm)	
T型槽(寬度x數量x間距) T-SLOTS(WxNOXD)	5/8x3x2 1/2in(16x3x63.5mm)	
左右行程 Longitudinal Travel	手動 Maunal	41.33(1050 mm)
	自動 Power Feed	39.4 in (1000 mm)
前後行程 Cross Travel	19.7 in (500 mm)	
上下行程 Vertical Knee Travel	23.62 in (600 mm)	
主軸錐度 Spindle Taper	ISO # 40	
主軸升降套行程 Spindle Quill Travel	5.5 in (140 mm)	
主軸馬達 Spindle Motor	3.75KW (5HP)	2.2KW (3HP)
變速方式 Change Of Speed	無段變速 Vaibale Speed	10段變速 10 Step Speed
主軸迴轉速度 Spindle Speed R.P.M.	80-3800rpm	80-3450rpm
主軸每轉進刀速率 Quill Power Feed Rate	0.0015,0.03,0.06 in (0.04,0.08,0.15 mm)	
頭部旋轉角度 Headstock Swivel&Incl	R & L 90°	
機械淨重 Machine Net Weight	2700 kgs	

*本公司保有變更設計之權利，如有更改不另行通知。
 Specifications subject to change without prior notice.
 * "OPT"指特殊選購配件。
 "OPT" means optional accessories.



BDV-6

BED TYPE MILLING MACHINE
 CNC BED TYPE MILLING MACHINE
 VERTICAL MILLING CENTER

EUMEGA MACHINERY WORKS CO., LTD

Photo shows may include some options.

MD(V)-2,MD(V)-3,MD(V)-3Q,MD(V)-4 外觀尺寸圖

VERTICAL TURRET MILLING MACHINE
 BED TYPE MILLING MACHINE
 CNC BED TYPE MILLING MACHINE
 VERTICAL MILLING CENTER

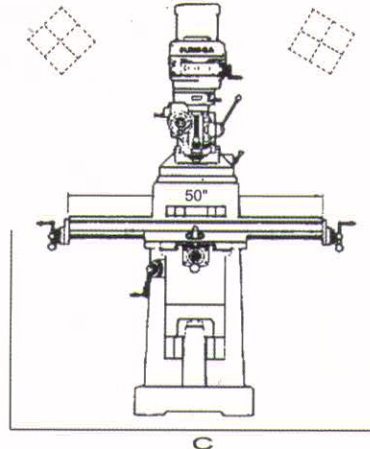
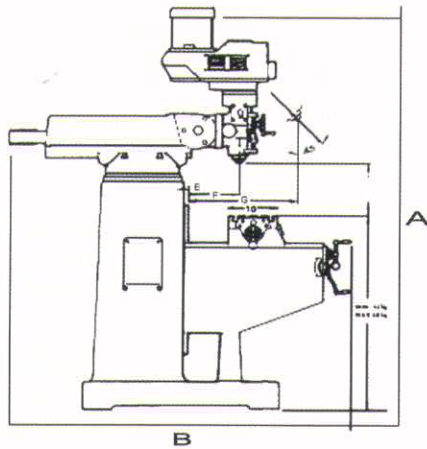

*本公司保有變更設計之權利，如有更改不另行通知。Specifications subject to change without prior notice.

UNIT:MM

MODEL	MDV-2	MDV-3	MDV-3Q	MDV-4
A	2075	2134	2134	2102
B	1600	2007	2007	2007
C	1440	2642	2642	2642
D	50~457	50~457	50~457	50~457
E	0~254	0~508	0~508	0~508
F	102~476	102~711	102~711	102~711
G	241~540	241~765	241~765	241~765
H	810~1215	810~1215	810~1215	810~1215

MD(V)-4.5,MD(V)-5SR,KM(V)-800 外觀尺寸圖

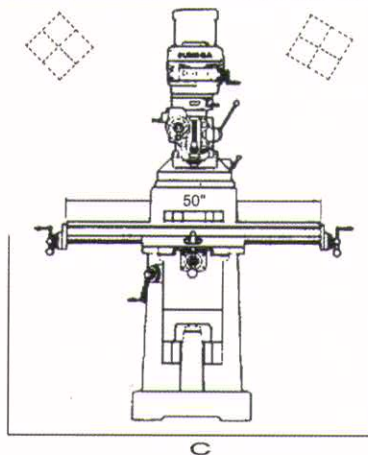
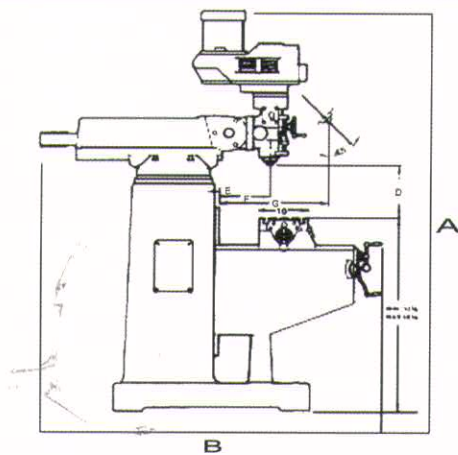

*本公司保有變更設計之權利，如有更改不另行通知。Specifications subject to change without prior notice. UNIT:MM

MODEL	MDV-4.5	MDV-5SR	KMV-800
A	2260	2450	2540
B	2007	2007	2007
C	2642	3175	2455
D	50~45	50~457	50~457
E	0~508	0~508	0~508
F	102~711	102~711	102~711
G	241~765	241~765	241~765
H	810~1215	810~1215	810~1215

BED TYPE MILLING MACHINE
 CNC BED TYPE MILLING MACHINE
 VERTICAL MILLING CENTER

EUMEGA MACHINERY WORKS CO., LTD

Photo shows may include some options.

BED TYPE MILLING MACHINE
 CNC BED TYPE MILLING MACHINE
 VERTICAL MILLING CENTER
 VERTICAL TURRET MILLING MACHINE

MDV-6SR(H) 外觀尺寸圖

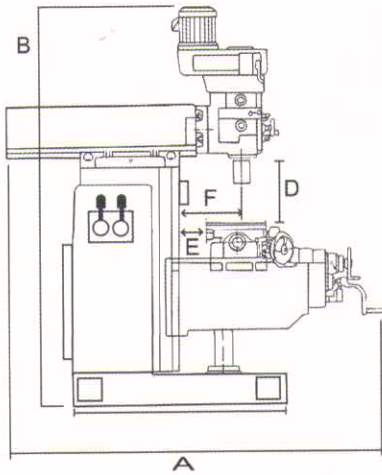

Unit:MM

A:	1950
B":	2400~2450
C:	1200
D:	130~575
E:	25~480
F:	180~710
G:	650
H:	2000
I:	360

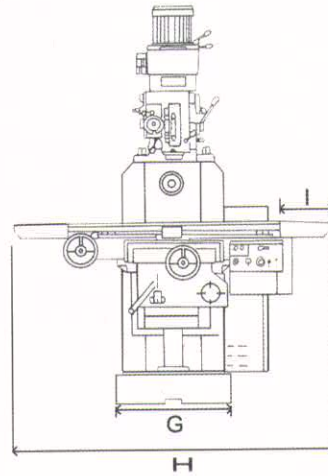

*本公司保有變更設計之權利，如有更改不另行通知。Specifications subject to change without prior notice.

BDV-6 外觀尺寸圖

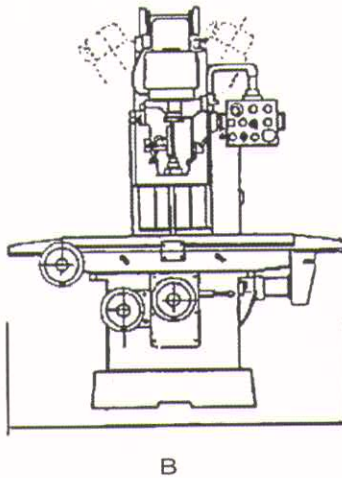

Unit:MM

A:	1780
B":	2360
C:	2170
D:	65~710
E:	480
F:	1200
G:	60~560
H:	2515

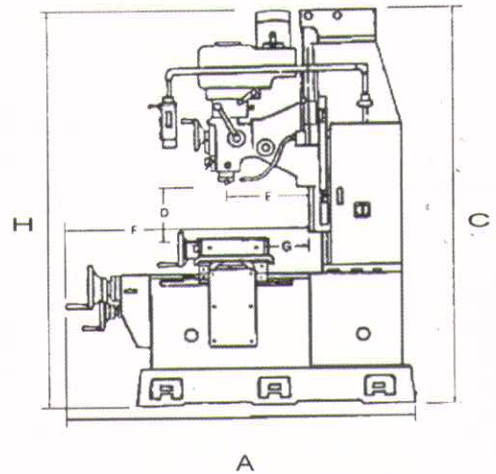

*本公司保有變更設計之權利，如有更改不另行通知。Specifications subject to change without prior notice.

◎ SR 系列標準配件 SR Series Standard Accessories

X&Y軸滾珠螺桿	Ball Screw For X&Y Axis	上下快送	Rapid Up/Down Motor
X&Y軸伺服馬達	Servo Motor For X&Y Axis	後檔渣皮	Rubber Way Cover For Rear
電器箱與控制面板	Electric Box With Controller Panel	工具箱	Tool Box With Tools
自動潤滑	Automatic Lubrication	零件與操作手冊	Parts & Operation Manual
前鐵護蓋	Front Steel Way Cover	拉桿	Manual Drawbar

◎ 一般標準配件 General Standard Accessories

手動潤滑	One Shot Hand Lubrication	工具箱、拉桿	Tool Box With Tools、Manual Drawbar
前後檔渣皮	Rubber Way Cover For F&R	零件與操作手冊	Parts & Operation Manual

◎ 特殊選購配件 Optional Accessories

橫銑主軸MD(V)-6SR	Horizontal Spindle For MD(V)-6SR	XYZ軸自動進刀	Table Power Feed For XYZ Axis
立主軸變頻馬達	Inverter Vertical Spindle Motor	電器箱與控制面板	Electric Box With Controller Panel
收水盤	Chip Tray	石英燈	Work Light
沖水系統	Coolant System	萬能夾具組	Clamping Kit Set
氣動拉桿	Air Power Drawbar	銑床夾頭	Milling Chucks
自動潤滑	Automatic Lubrication	虎鉗	Vise

BED TYPE MILLING MACHINE
 CNC BED TYPE MILLING MACHINE
 VERTICAL MILLING CENTER

EUMEGA MACHINERY WORKS CO., LTD

Photo shows may include some options.

特殊配件

Optional Accessories

VERTICAL TURRET MILLING MACHINE
 BED TYPE MILLING MACHINE
 CNC BED TYPE MILLING MACHINE
 VERTICAL MILLING CENTER



2.3.4有段頭
STEP SPEED HEAD



2.3.4無段頭
VARIABLE SPEED HEAD

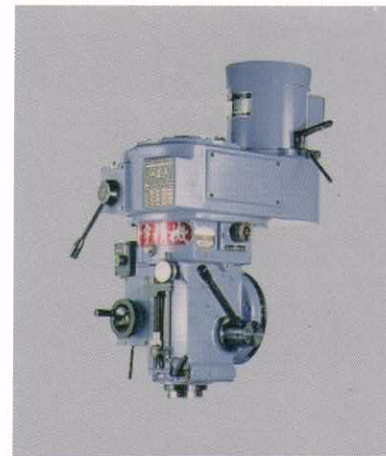

強力有段頭 (變頻)
STEP SPEED & INVERTER HEAD
CIRCULAPION LUBRICANT SYSTEM.



4.5,5,5SR,6SR有段頭
STEP SPEED HEAD



4.5,5,5SR,6SR無段頭
VARIABLE SPEED HEAD



自動進刀機
POWER FEED



X軸齒輪式自動進刀
GEAR TYPE POWER FEED FOR X AXIS



Y軸齒輪式自動進刀
GEAR TYPE POWER FEED FOR Y AXIS



Z軸齒輪式自動進刀
GEAR TYPE POWER FEED FOR Z AXIS

BED TYPE MILLING MACHINE
CNC BED TYPE MILLING MACHINE
VERTICAL MILLING CENTER

EUMEGA MACHINERY WORKS CO., LTD

Photo shows may include some options.

VERTICAL TURRET MILLING MACHINE

BED TYPE MILLING MACHINE

CNC BED TYPE MILLING MACHINE

VERTICAL MILLING CENTER

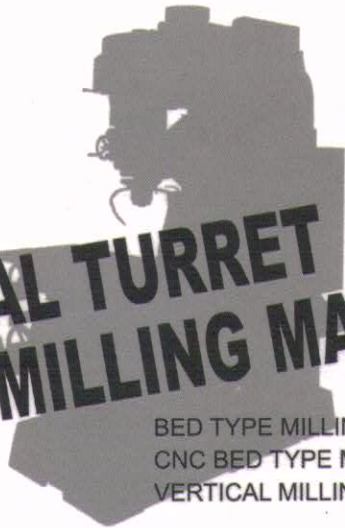

**VERTICAL TURRET
MILLING MACHINE**

BED TYPE MILLING MACHINE

CNC BED TYPE MILLING MACHINE

VERTICAL MILLING CENTER

EUMEGA
PRECISION MILLS

金宇精機廠股份有限公司

EUMEGA MACHINERY WORKS CO., LTD

桃園縣 325 龍潭鄉 龍源路 30 巷 38 號
No. 38, Lane 30, Longyuan Road, Longtan
Township, Taoyuan County, 325 Taiwan R.O.C.
TEL: 886-3-411-6618 FAX: 886-3-411-6088
E-mail: eumega@ms15.hinet.net

Distributor

--