



金 宇 精 機

EUMEGA MACHINERY WORKS CO., LTD

Accuracy

Superior Quality

High Performance

High Efficiency



Vertical Turret Milling Machine
Vertical & Horizontal Milling Machine



MDV-2 & MD-2

單位UNIT: INCH (MM)

工作台尺寸 Table Size	9x42 (229x1067) OR 9x49 (229 x 1245) OPT	
T型槽 T-Slots (Wx NOxD)	5/8x3x2 (16x3x63)	
三軸行程 Travel for XYZ	30x12x16 (762x305x406)	
主軸行程 Spindle Quill Travel	5 (127)	
伸臂行程 Ram Travel	12 (305)	
主軸馬達 Spindle Motor	3HP	
主軸錐度 Spindle Taper	R8 OR ISO30	
變速方式	有段 MD	8段變速 8 Step Speed
Change of Speed	無段 MDV	無段變速 Variable Speed
主軸迴轉速度	有段 MD	80-2720 RPM
Spindle Speed R.P.M.	無段 MDV	60-4200 RPM
頭部旋轉角度 Headstock Swivel & Incline	R & L 90° F & B 45°	
淨重 Net Weight	1000 KGS	

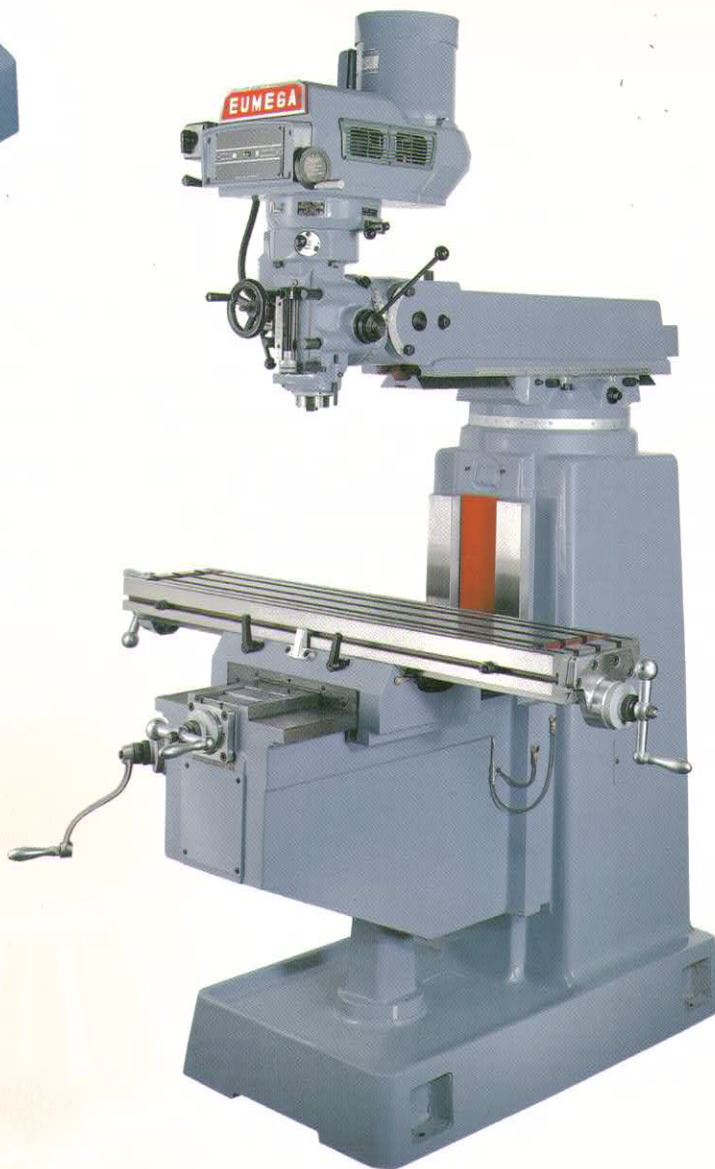

MDV-4 & MD-4

單位UNIT: INCH (MM)

工作台尺寸 Table Size	10x50 (254x1270) OR (254x1371) OR (279x1320) OPT	
T型槽 T-Slots (Wx NOxD)	5/8x3x2 (16x3x63)	
三軸行程 Travel for XYZ	36x15.75x16 (914x400x406)	
主軸行程 Spindle Quill Travel	5 (127)	
伸臂行程 Ram Travel	24 (610)	
主軸馬達 Spindle Motor	3HP	
主軸錐度 Spindle Taper	R8 OR ISO30	
變速方式	有段 MD	8段變速 8 Step Speed
Change of Speed	無段 MDV	無段變速 Variable Speed
主軸迴轉速度	有段 MD	80-2720 RPM
Spindle Speed R.P.M.	無段 MDV	60-4200 RPM
頭部旋轉角度 Headstock Swivel & Incline	R & L 90° F & B 45°	
淨重 Net Weight	1350 KGS	

MDV-3 & MD-3

單位UNIT: INCH (MM)

工作台尺寸 Table Size	10x50 (254x1270) OR (254x1371) OR (279x1320) OPT	
T型槽 T-Slots(W x NOx D)	5/8x3x2 (16x3x63)	
三軸行程 Travel for XYZ	36x15.75x16 (914x400x406)	
主軸行程 Spindle Quill Travel	5 (127)	
伸臂行程 Ram Travel	24 (610)	
主軸馬達 Spindle Motor	3HP	
主軸錐度 Spindle Taper	R8 OR ISO30	
變速方式 Change of Speed	有段 MD	8段變速 8 Step Speed
	無段 MDV	無段變速 Variable Speed
主軸迴轉速度 Spindle Speed R.P.M.	有段 MD	80-2720 RPM
	無段 MDV	60-4200 RPM
頭部旋轉角度 Headstock Swivel & Incline	R & L 90° F & B 45°	
淨重 Net Weight	1200 KGS	

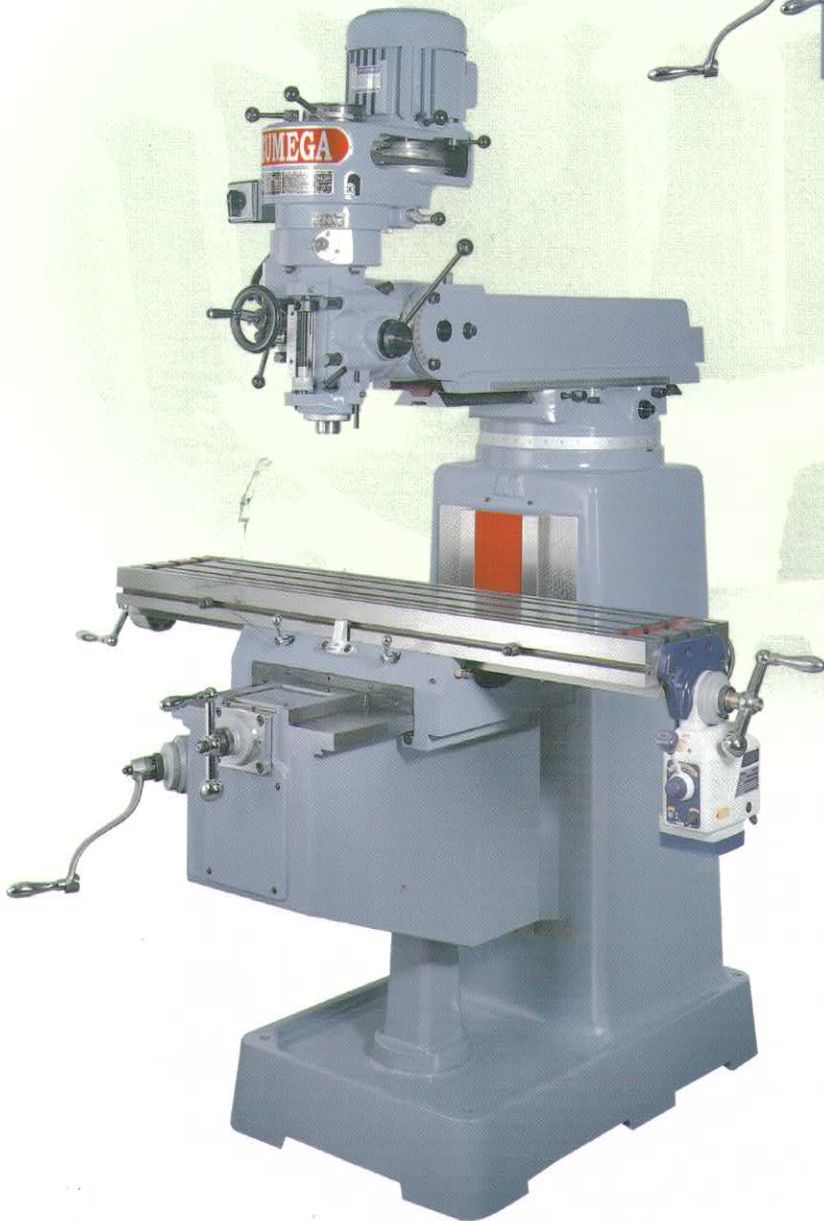
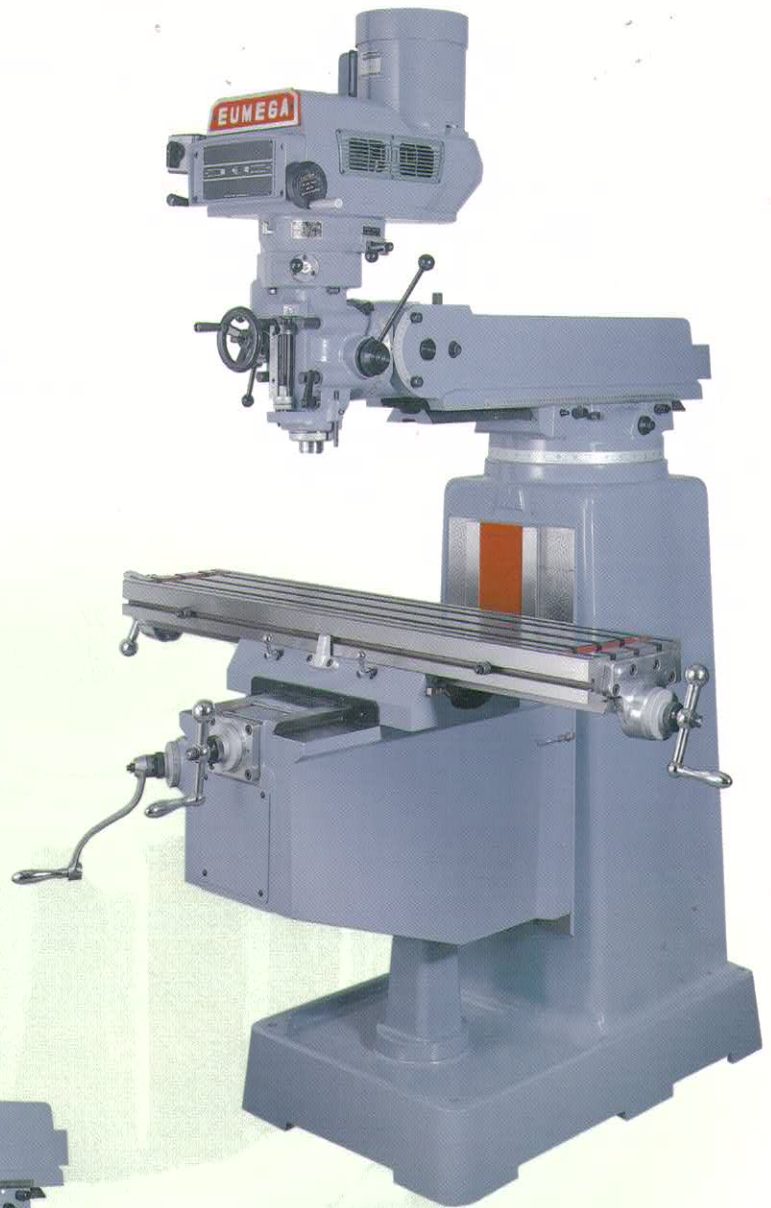

MD-3Q & MDV-3Q

單位UNIT: INCH (MM)

工作台尺寸 Table Size	10x50 (254x1270) OR (254x1371) OR (279x1320) OPT	
T型槽 T-Slots(W x NOx D)	5/8x3x2 (16x3x63)	
三軸行程 Travel for XYZ	36x15.75x16 (914x400x406)	
主軸行程 Spindle Quill Travel	5 (127)	
伸臂行程 Ram Travel	24 (610)	
主軸馬達 Spindle Motor	3HP	
主軸錐度 Spindle Taper	R8 OR ISO30	
變速方式 Change of Speed	有段 MD	8段變速 8 Step Speed
	無段 MDV	無段變速 Variable Speed
主軸迴轉速度 Spindle Speed R.P.M.	有段 MD	80-2720 RPM
	無段 MDV	60-4200 RPM
頭部旋轉角度 Headstock Swivel & Incline	R & L 90° F & B 45°	
淨重 Net Weight	1200 KGS	

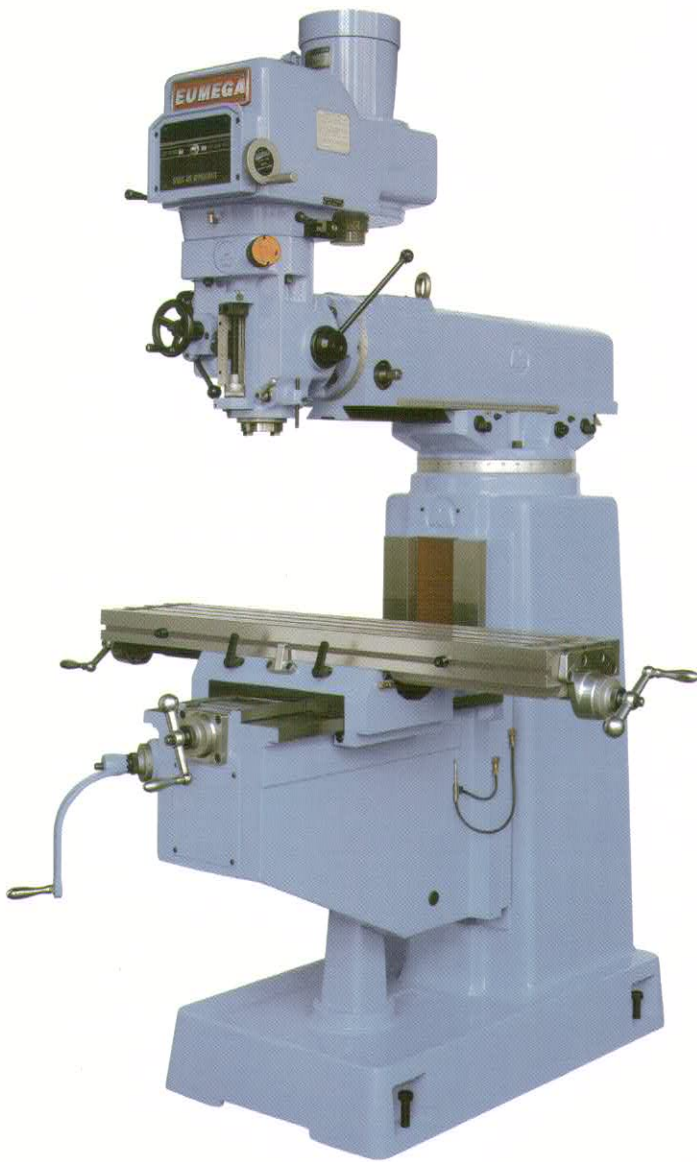

MDV-4.5

單位UNIT: INCH (MM)

工作台尺寸 Table Size	10x50 (254x1270) OR (254x1371) OR (279x1320) OPT
T型槽 T-Slots(W x NO x D)	5/8x3x2 (16x3x63)
三軸行程 Travel for XYZ	36x16x18 (914x406x450)
主軸行程 Spindle Quill Travel	5.51 (140)
伸臂行程 Ram Travel	24 (610)
主軸馬達 Spindle Motor	5HP
主軸錐度 Spindle Taper	ISO 40
變速方式 Change of Speed	無段變速 Variable Speed
主軸迴轉速度 Spindle Speed R.P.M.	80-3800 RPM
頭部旋轉角度 Headstock Swivel & Incline	R & L 90°
淨重 Net Weight	1700 KGS

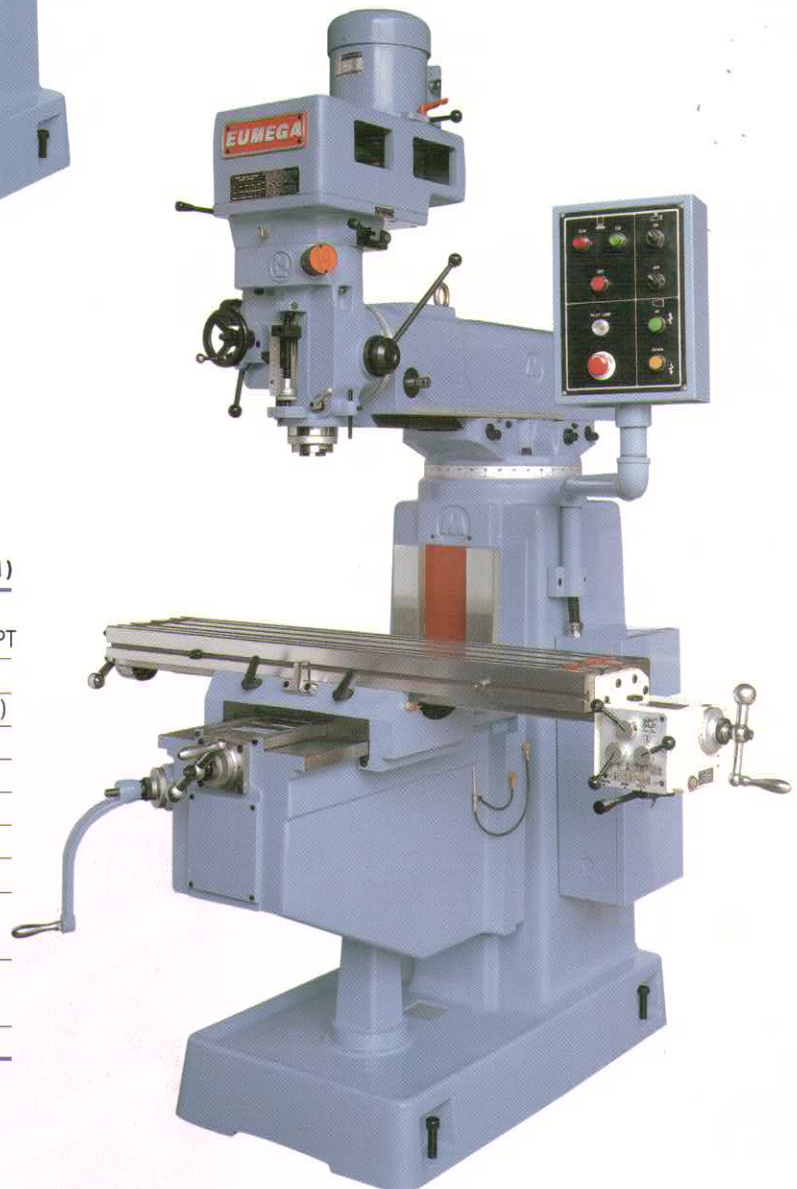

MD-4.5

單位UNIT: INCH (MM)

工作台尺寸 Table Size	10x50 (254x1270) OR (254x1371) OR (279x1320) OPT
T型槽 T-Slots(W x NO x D)	5/8x3x2 (16x3x63)
三軸行程 Travel for XYZ	36x16x18 (914x406x450)
主軸行程 Spindle Quill Travel	5.51 (140)
伸臂行程 Ram Travel	24 (610)
主軸馬達 Spindle Motor	3HP
主軸錐度 Spindle Taper	ISO 40
變速方式 Change of Speed	10段變速 10 Step Speed
主軸迴轉速度 Spindle Speed R.P.M.	80-3450 RPM
頭部旋轉角度 Headstock Swivel & Incline	R & L 90°
淨重 Net Weight	1700 KGS



● MDV-6SRH & MD-6SRH

砲塔式立橫兩用銑床



● MDB-6SRH & MDBI-6SRH

變頻式強力無段頭

Variable Inverter Head

頭部循環式潤滑系統

Head Circulation Lubricant System

The above 6SR model is also available for MD(V/B/BI)-6SR (No Horizontal spindle) 以上機種亦適用於MD (V/B/BI)-6SR(不裝配橫銑主軸)

規格表 Specifications

單位UNIT:MM (INCH)

機型 Model	MD-6SR(H) / MDV-6SR(H)	
工作台尺寸 Table Size	305 x 1270 (12 x 50)	
鞍座寬度 Saddle Width	965 (38)	
T型槽(寬度x數量x間距) T-Slots(WxNOxD)	16x3x63 (5/8x3x2)	
左右行程 Longitudinal Travel	800 (31.5)	
前後行程 Cross Travel	460 (18)	
上下行程 Vertical Knee Travel	500 (19.69)	
伸臂行程 Ram Travel	24 (610)	
X & Y 軸伺服馬達 X & Y Axis Servo Motor	1HP	
X & Y 軸進給速率 X & Y Axis Feed Rate	0~1000 MM-MIN	
上下快速馬達 Knee Rapid Up/Down Motor	3/4 HP	
上下進給速率 Knee Feed Rate	800 MM/MIN	
頭部旋轉角度 Headstock Swivel & Incline	R & L 90°	
立銑主軸 VERTICAL SPINDLE		
主軸錐度 Spindle Taper	ISO 40	
主軸馬達 Spindle Motor	有段 MD	3 HP
	無段 MDV	5 HP
主軸升降套行程 Spindle Quill Travel	140 (5.5)	
主軸迴轉速度 Spindle Speed R.P.M.	有段 MD	80~3450 RPM (10段變速 10 Step Speed)
	無段 MDV	70~3500 RPM (無段變速 Variable Speed)
主軸每轉進刀速率 Quill Power Feed Rate	0.04, 0.08, 0.15 (0.0015, 0.003, 0.006) REV	
橫銑主軸 HORIZONTAL SPINDLE		
橫主軸錐度 Spindle Taper	ISO 40	
橫主軸馬達 Spindle Motor	3 HP	
橫主軸迴轉速度 Spindle Speed R.P.M.	80~1355 RPM (8段變速 / 8 Step Speed)	
橫銑主軸中心至工作台面 Distance From Spindle Center To Table Surface	-70~375	
橫銑主軸中心至伸出臂底面距離 Distance From Spindle Center To Bottom Of Arm	220	
淨重 Net Weight	2600KGS	

- 本公司保有變更設計之權利，如有更改不另行通知。 specifications subject to change without prior notice.
- "OPT"指特殊選購配件。"OPT" means optional accessories.
- 本目錄之照片含有某些選購配件。All of photos show some option.

◎ SR 系列標準配件 SR Series Standard Accessories			
X & Y 軸滾珠螺桿	Ball Screw For X&Y Axis	上下快送	Rapid Up/Down Motor
X & Y 軸伺服馬達	Servo Motor For X&Y Axis	後檔渣皮	Rubber Way Cover For Rear
電器箱與控制面板	Electric Box With Controller Panel	工具箱	Tool Box With Tools
自動潤滑	Automatic Lubrication	零件與操作手冊	Parts & Operation Manual
前鐵護蓋	Front Steel Way Cover	拉桿	Manual Drawbar
◎ 一般標準配件 General Standard Accessories			
手動潤滑器	One Shot Hand Lubrication	工具箱、拉桿	Tool Box With Tools、Manual Drawbar
前後檔渣皮	Rubber Way Cover For F&R	零件與操作手冊	Parts & Operation Manual
◎ 特殊選購配件 Optional Accessories			
橫銑主軸 MD(V)-6SR	Horizontal Spindle For MD(V)-6SR	XYZ 軸自動進刀	Table Power Feed For XYZ Axis
立主軸變頻馬達	Inverter Vertical Spindle Motor	電器箱與控制面板	Electric Box With Controller Panel
收水盤	Chip Tray	石英燈	Work Light
沖水系統	Coolant System	萬能來具組	Clamping Kit Set
氣動拉桿	Air Power Drawbar	銑床夾頭	Milling Chucks
自動潤滑	Automatic Lubrication	虎鉗	Vise



金宇精機廠股份有限公司

EUMEGA MACHINERY WORKS CO., LTD.

台北縣新莊市三和路一之三號

1-3, SAN HO ROAD, HSIN CHUANG CITY, TAIPEI HSIEN, 242 TAIWAN, R.O.C

TEL:886-2-2907-1358 FAX:886-2-2907-1326 E-mail:eumega@ms15.hinet.net