



# *CNC Vertical Turret Milling Machine*

## **KM-800L**

**CNC數值  
控制式銑床**





# 規格表 Specifications

單位 UNIT : MM ( INCH )

機型 Model	KM-800L
工作台尺寸 Table size	12"×50" ( 305×1270mm), 12"×60" ( 305×1524mm) opt
T型槽(寬度×數量×間距) T-Slots(W×NO×D)	5/8"×3"×2 1/2" (18x3x63.5mm)
三軸行程 Travel for XYZ	131.5"×15.9"×17.7" (800x406x450mm) 39.5" x15.9"×17.7" (1000 x406x450mm)opt 47.2" x15.9"×17.7" (1200 x406x450mm)opt
主軸行程Z軸 Spindle Travel For Z Axis	7.9" (200mm)
伸臂行程 Ram Travel	24" (610mm)
主軸馬達 Variable Spindle Motor	5 HP
主軸錐度 Spindle Taper	ISO 40 Quill
主軸轉速 Variable Speed R.P.M.	0-4000 RPM
頭部旋角度 Headstock Swivel & Incline	R & L 450
機械淨重 Machine Net Weight	2200KGS

## 外觀尺寸圖 Distance

- 本公司對產品不斷研究改進，因此保有隨時更改設計、規格、尺寸及機械結構之權利，如蒙惠顧時，請確認是否有變更。
- Specifications subject to change without priop notice.

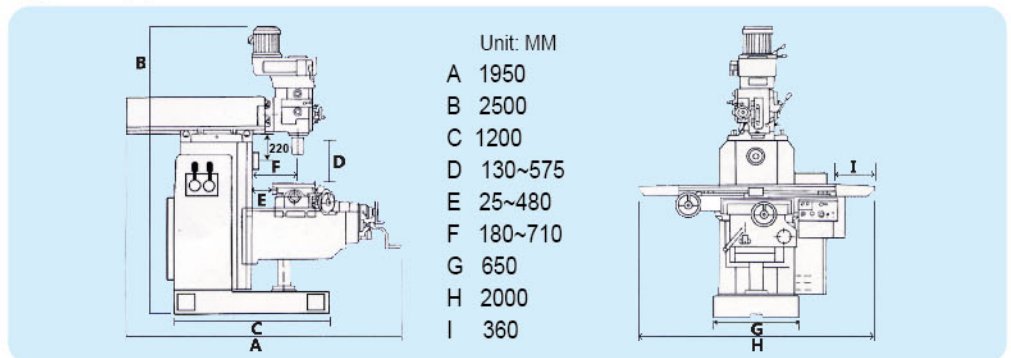

### 標準配件：

- X & Y軸滾珠螺桿
- X & Y軸伺服馬達
- 電氣箱與控制面板
- 自動潤滑
- 上下快送
- 前鐵護蓋
- 後檔渣皮
- 工具箱、拉桿
- 零件與操作手冊
- 氣動拉桿
- 石英燈

### Standard Accessories:

- Ball screw for X & Y axis
- Servo motor for X & Y axis
- Electric box with controller panel
- Automatic lubrication
- Rapid up / down motor
- Front steel way cover
- Rubber way cover for rear
- Tool box with tools, Manual drawbar
- Parts & operation manual
- Air power drawbar
- Work light

### 選購配件：

- 收水盤
- 沖水系統
- 萬能夾具組
- 虎鉗
- 銑床夾頭

### Optional Accessories:

- Chip tray
- Coolant system
- Clamping kit set
- Vise
- Milling chuck



金宇精機廠股份有限公司  
EUMEGA MACHINERY WORKS CO., LTD.

<http://www.eumega.com.tw> E-MAIL: [eumega@ms15.hinet.net](mailto:eumega@ms15.hinet.net)

桃園縣龍潭鄉龍源路30巷38號 TEL: 886-3-4116618 FAX: 886-3-4116088  
NO.38, LANE 30, LONGYUAN ROAD, LONGTAN TOWNSHIP, TAOYUAN COUNTY, 325 TAIWAN R.O.C.

