



# Vertical Turret Milling Machine

**X & Y & Z axis travel:**

**MDI-3Q**

**X & Y & Z 行程：**

**X軸：914 mm**

**Y軸：400 mm**

**Z軸：406 mm**



# 規格表 Specifications

單位 unit : inch (mm)

機型 Model	MDI-3Q
工作台尺寸 Table Size	10×50 (245×1270) 或 or 10×54 (254×1371) OPT
T型槽(寬度×數量×間距) T-Slots (WxNOxD)	5/8 x 3 x 2 1/2 x (16x3x63.5)
左右行程 Longitudinal Travel	36 (914) 32.5 (825)
前後行程 Cross Travel	15.75 (400)
上下行程 Vertical Knee Travel	16 (406)
伸臂行程 Spindle Quill Travel	24 (610)
主軸錐度 Spindle Taper	R8 OR ISO30 OR ISO40 (OPTIONAL)
主軸馬達 Spindle Motor	2.2kw (3HP)
主軸升降套行程 Speed Quill Travel	5 (127)
變速方式 Change of Speed	電子式無段變速 INVERTER SPEED
主軸迴轉速度 Spindle Speed R.P.M.	0~4200
主軸每轉進刀速率 Quill Power Feed Rate	0.0015, 0.003, 0.006/(0.04, 0.08, 0.15)REV
機台淨重 Machine Net Weight	1200 KGS (2640 LBS)

## 外觀尺寸圖 Distance

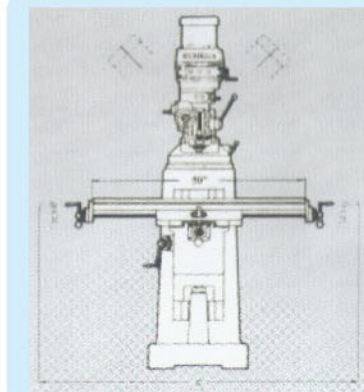

Unit: Inch(MM)

A overall height	84(2134)
B overall width	79(2000)
C overall width	104(2642)
D min. -max.	2-18(50-457)
E min. -max.	0-20(0-508)
F min. -max.	4-28 3/4(102-711)
G min. -max.	9 1/2-30 1/8(241-765)

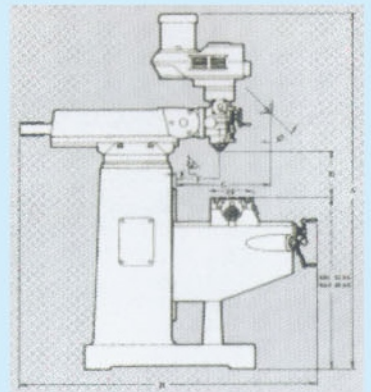

- 本公司對產品不斷研究改進，因此保有隨時更改設計、規格、尺寸及機械結構之權利，如蒙惠顧時，請確認是否有變更。
- Specifications subject to change without priop notice.
- Q: 表示Y軸為方型滑道
- Q: Square priop notice.
- MD-3(Q)亦可特殊選購16段變速
- Optional: 16 Step speeds is ovaivable for MD-3(Q)

### 標準配件：

- 零件與操作手冊
- 工具箱
- 拉桿
- 手動潤滑器
- 前後擋渣皮

### Standard Accessories:

- Parts & operation manual
- Tool Box with Tools
- Manual Drawbar
- One Shot Hand Lubrication
- Rubber Way Cover for Front & Rear

### 選購配件：

- X, Y, Z軸自動進刀
- 電氣箱與控制面板
- 沖水系統
- 石英燈
- 氣動鎖刀
- 收水盤

### Optional Accessories:

- Tabel Power (X, Y, Z)
- Electric Box with Controller Panel
- Coolant Pump
- Work Light
- Air Power Drawbar
- Base Chip Tray