

# SC 3-JAW SCROLL CHUCKS

## 普通型三爪夾頭

尺寸圖 » Dimensions

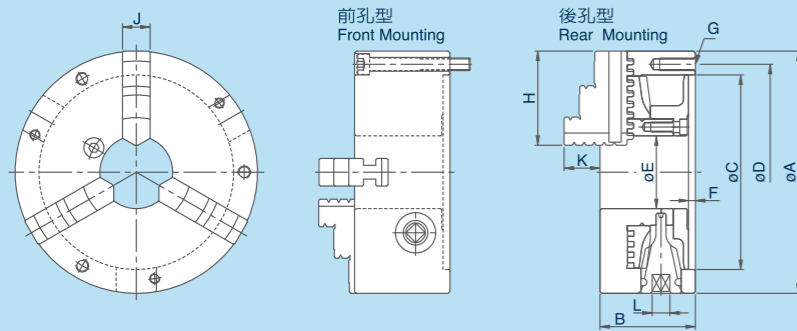

規格表 » Specifications

單位/UNIT:mm

型式/規格 MODEL /SPEC.	A	B	C	D	E	F	G	H	J	K	L	最高迴轉速 Max.Speed r.p.m.(min <sup>-1</sup> )	把握範圍 外徑把握 O.D.Clamping	Max. Gripping Diameter 內徑把握 I.D.Clamping	淨重 Weight (kg)
SC-03	85	45	60	73	16	3.5	3-M6x1P	35	11	15	7	2500	ø2-ø70	ø24-ø64	1.5
SC-04	112	58	80	95	24	4.5	3-M8x1.25P	42	14	17	8	2500	ø3-ø90	ø32-ø84	3.3
SC-05	132	60	100	115	32	4.5	3-M8x1.25P	50	16	20	8	2500	ø3-ø110	ø35-ø100	4.6
SC-06	167	66	130	147	45	5	3-M10x1.5P	65	19	23	10	2000	ø4-ø160	ø48-ø150	7.9
SC-07	193	76	155	172	58	5	3-M10x1.5P	75	22	28	11	2000	ø4-ø180	ø56-ø170	12.0
SC-08	203	76	160	176	58	5	3-M10x1.5P	75	22	28	11	2000	ø4-ø180	ø56-ø170	13.3
SC-09	233	84	190	210	70	5.5	3-M12x1.75P	85	24	34.5	12	2000	ø5-ø220	ø62-ø210	19.3
SC-10	273	86	230	250	89	5.5	3-M12x1.75P	98	28	39	12	1800	ø6-ø260	ø70-ø250	26.2
SC-12	310	96	260	285	105	7	3-M12x1.75P	110	30	45	14	1800	ø10-ø300	ø86-ø290	37.6
SC-14	355	112	300	328	127	7	6-M12x1.75P	132	35	50	15	1500	ø12-ø350	ø96-ø320	57.2
SC-16	405	122	345	375	160	8	6-M14x2P	146	40	56	15	1500	ø14-ø400	ø100-ø380	80.7

# PS 4-JAW SCROLL CHUCKS

## 連動型四爪夾頭

尺寸圖 » Dimensions

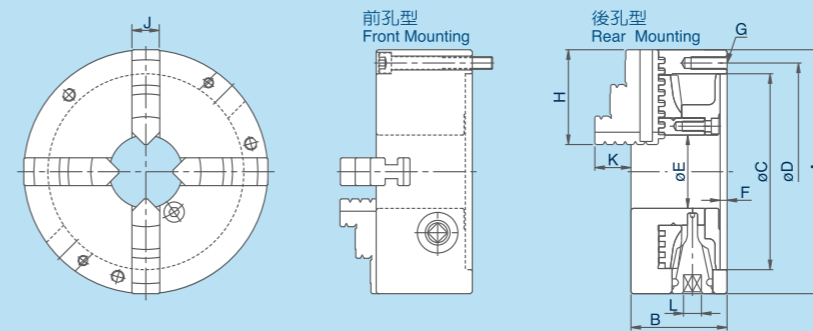

規格表 » Specifications

單位/UNIT:mm

型式/規格 MODEL /SPEC.	A	B	C	D	E	F	G	H	J	K	L	最高迴轉速 Max.Speed r.p.m.(min <sup>-1</sup> )	把握範圍 外徑把握 O.D.Clamping	Max. Gripping Diameter 內徑把握 I.D.Clamping	淨重 Weight (kg)
PS-07	193	76	155	172	58	5	3-M10x1.5P	75	22	28	11	2000	ø4-ø180	ø56-ø170	12.1
PS-09	233	84	190	210	70	5.5	3-M12x1.75P	85	24	34.5	12	2000	ø5-ø220	ø62-ø210	19.4
PS-12	310	96	260	285	105	7	3-M12x1.75P	110	30	45	14	1800	ø10-ø300	ø86-ø290	38.1
PS-16	405	122	345	375	160	8	6-M14x2P	146	40	56	15	1500	ø14-ø400	ø100-ø380	82.4

# AS 6-JAW AWL TYPE CHUCKS

## 錐型六爪夾頭

尺寸圖 » Dimensions

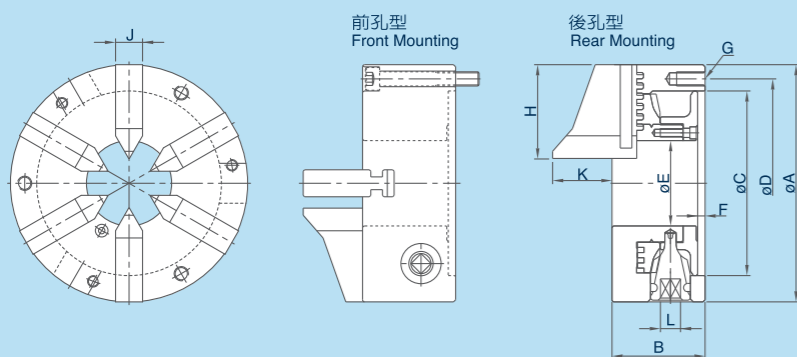

規格表 » Specifications

單位/UNIT:mm

型式/規格 MODEL /SPEC.	A	B	C	D	E	F	G	H	J	K	L	最高迴轉速 Max.Speed r.p.m.(min <sup>-1</sup> )	把握範圍 外徑把握 O.D.Clamping	Max. Gripping Diameter 內徑把握 I.D.Clamping	淨重 Weight (kg)
AS-04	112	58	80	95	32	4.5	3-M8x1.25P	45	14	46	8	1200	ø2-ø32		3.8
AS-06	167	65	130	147	60	5.0	3-M10x1.5P	66	19	43	10	1200	ø3-ø60		8.2

# AE 8-JAW AWL TYPE CHUCKS

## 錐型八爪夾頭

尺寸圖 » Dimensions

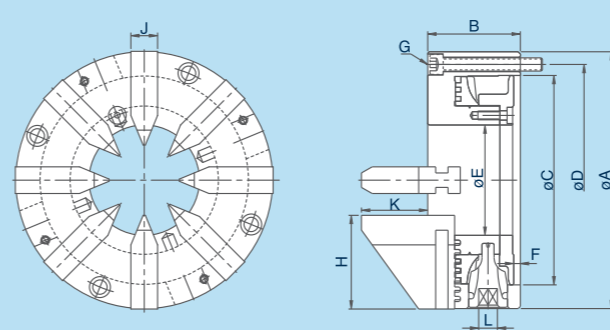

規格表 » Specifications

單位/UNIT:mm

型式/規格 MODEL /SPEC.	A	B	C	D	E	F	G	H	J	K	L	最高迴轉速 Max.Speed r.p.m.(min <sup>-1</sup> )	把握範圍 外徑把握 O.D.Clamping	Max. Gripping Diameter 內徑把握 I.D.Clamping	淨重 Weight (kg)
AE-09	233	84	190	210	100	5.5	4-M12x1.75P	85	24	60	12	1000	ø7-ø100		21

# SK 3-JAW POWERFUL TYPE SCROLL CHUCKS

## 強力型三爪夾頭 SKB:大孔徑 Larger Through Hole

尺寸圖 > Dimensions

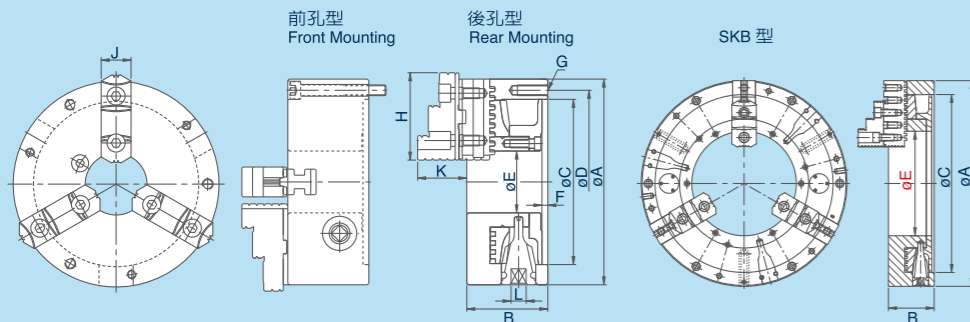

規格表 > Specifications

單位/UNIT:mm

型式/規格 MODEL / SPEC.	A	B	C	D	E	F	G	H	J	K	L	最高迴轉速 Max.Speed r.p.m.(min <sup>-1</sup> )	把握範圍 Max. Gripping Diameter 外徑把握 O.D.Clamping	內徑把握 I.D.Clamping	淨重 Weight (kg)
SK-04	112	58	80	95	24	4.5	3-M8x1.25P	47	19	31.5	8	2500	ø3-ø100	ø35-ø93	3.45
SK-05	132	60	100	115	32	4.5	3-M8x1.25P	57	24	36	8	2500	ø3-ø123	ø43-ø122	5.0
SK-06	167	66	130	147	45	5	3-M10x1.5P	68	26	39	10	2000	ø8-ø160	ø55-ø150	8.6
SK-07	193	76	155	172	58	5	3-M10x1.5P	82	28	43	11	2000	ø8-ø180	ø62-ø170	12.8
SK-08	203	76	160	176	58	5	3-M10x1.5P	82	28	43	11	2000	ø8-ø180	ø62-ø170	14.1
SK-09	233	84	190	210	70	5.5	3-M12x1.75P	93	32	50	12	2000	ø11-ø220	ø70-ø210	20.4
SK-10	273	86	230	250	89	5.5	3-M12x1.75P	102	35	54.5	12	1800	ø12-ø260	ø80-ø250	26.7
SK-12	310	96	260	285	105	7	3-M12x1.75P	118	40	56	14	1800	ø15-ø300	ø90-ø290	39.3
SK-14	355	112	300	328	127	7	6-M12x1.75P	139	45	70.5	15	1500	ø25-ø350	ø110-ø320	60.7
SK-16	405	122	345	375	160	8	6-M14x2P	150	50	75	15	1500	ø30-ø400	ø110-ø380	82.3
SK-20	500	140	420	458	205	5.5	6-M16x2P	140	55	84	19	1000	ø25-ø480	ø125-ø460	145.5
SK-25	630	140	545	586	275	6.5	6-M16x2P	140	70	92	19	850	ø80-ø630	ø198-ø601	221.3
SKB-25	630	140	545	586	320	6.5	6-M16x2P	140	70	92	19	850	ø160-ø630	ø274-ø646	208.5

# PSK 4-JAW POWERFUL TYPE SCROLL CHUCKS

## 強力連動型四爪夾頭 PSKB:大孔徑 Larger Through Hole

尺寸圖 > Dimensions

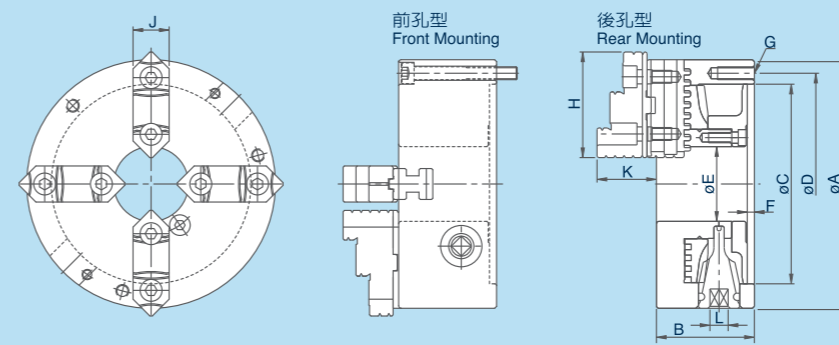

規格表 > Specifications

單位/UNIT:mm

型式/規格 MODEL / SPEC.	A	B	C	D	E	F	G	H	J	K	L	最高迴轉速 Max.Speed r.p.m.(min <sup>-1</sup> )	把握範圍 Max. Gripping Diameter 外徑把握 O.D.Clamping	內徑把握 I.D.Clamping	淨重 Weight (kg)
PSK-07	193	76	155	172	58	5	3-M10x1.5P	82	28	43	11	2000	ø8-ø180	ø62-ø170	12.7
PSK-09	233	84	190	210	70	5.5	3-M12x1.75P	93	32	50	12	2000	ø11-ø220	ø70-ø210	20.8
PSK-12	310	96	260	285	105	7	3-M12x1.75P	118	40	56	14	1800	ø15-ø300	ø90-ø290	43
PSK-16	405	122	345	375	160	8	6-M14x2P	150	50	75	15	1500	ø30-ø400	ø110-ø380	86.7
PSK-20	500	140	420	458	205	5.5	6-M16x2P	140	55	84	19	1000	ø25-ø480	ø125-ø460	149
PSKB-25	630	140	545	586	320	6.5	6-M16x2P	140	70	92	19	850	ø160-ø630	ø274-ø646	215

# A1(A2) 3-JAW A1(A2) TYPE CHUCKS

## 直裝型三爪夾頭

尺寸圖 > Dimensions

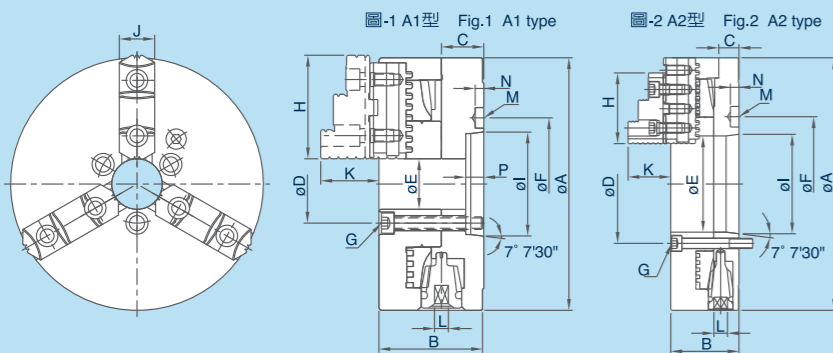

規格表 > Specifications

單位/UNIT:mm

型式/規格 MODEL / SPEC.	A	B	C	D	E	F	G	H	I	J	K	L	P	M	N	參考圖 Reference Drawing	最高迴轉速 Max.Speed r.p.m.(min <sup>-1</sup> )	把握範圍 Max. Gripping Diameter 外徑把握 O.D.Clamping	內徑把握 I.D.Clamping	淨重 Weight (kg)
A15-08"	200	83	33.5	61.9	40	ø104.8	3-M10x1.5P	82	82.563	28	43	11	14.29	ø16.3	6.8	圖-1 fig.1	2000	ø8-ø180	ø62-ø170	17.4
A16-08"	200	83	33.5	82.6	56	ø133.4	3-M12x1.75P	82	106.375	28	43	11	15.88	ø19.3	6.8	圖-1 fig.1	2000	ø8-ø180	ø62-ø170	18
A16-10"	255	91.5	36.5	82.6	56	ø133.4	3-M12x1.75P	93	106.375	32	50	12	15.88	ø19.3	6.8	圖-1 fig.1	1800	ø11-ø240	ø70-ø230	30.6
A211-20"	500	135	40	235	190.5	ø235	6-M20x2.5P	140	196.869	55	84	19	--	ø29.4	10.7	圖-2 fig.2	1000	ø25-ø480	ø125-ø460	161.5

# D1 3-JAW D1 TYPE CHUCKS

## 直裝型三爪夾頭

尺寸圖 > Dimensions

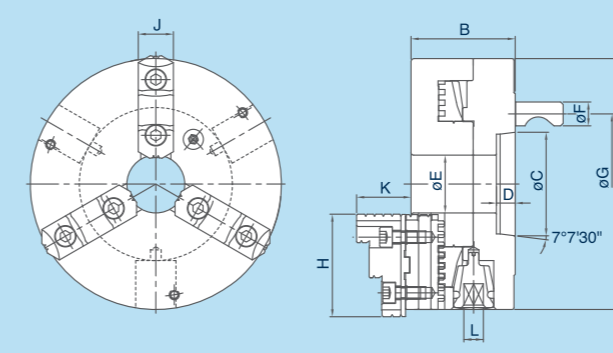

規格表 > Specifications

單位/UNIT:mm

型式/規格 MODEL / SPEC.	A	B	C	D	E	F	G	H	J	K	L	最高迴轉速 Max.Speed r.p.m.(min <sup>-1</sup> )	把握範圍 Max. Gripping Diameter 外徑把握 O.D.Clamping	內徑把握 I.D.Clamping	淨重 Weight (kg)
D15-08"	200	83	82.563	15	46	19	104.8	82	28	43	11	2000	ø8-ø180	ø62-ø170	17.8
D16-08"	200	83	106.375	16	58	22.2	133.4	82	28	43	11	2000	ø8-ø180	ø62-ø170	17.3
D16-10"	255	94	106.375	16	76	22.2	133.4	93	32	50	12	1800	ø11-ø240	ø70-ø230	31.3
D18-10"	255	94	139.719	18	76	25.4	171.4	93	32	50	12	1800	ø11-ø240	ø70-ø230	30.9
D18-12"	310	105	139.719	18	103	25.4	171.4	118	40	56	14	1800	ø15-ø300	ø90-ø290	51.1
D111-20"	500	135	196.869	--	190.5	30.2	235	140	55	84	19	1000	ø25-ø480	ø125-ø460	165.5