



蒲菲科技有限公司
PERFECT TECHNOLOGY CO., LTD.

2019



PRODUCT CATALOG

ABOUT US

Perfect technology Co.,Ltd is established in 1995 .We are original manufacturer and trade company. Our company had been 18 years experience in produce kinds of CNC Mechanical tool. For example Z Axis Setter, Clamping Force Gauge, Tool Holders, collet and Edge Finder etc. Famous of the best quality and competitive prices, package and rapid delivery. Therefore, we can fully satisfy your demand and have a numerous of customer. We have a good partnership with all over the world. Sweden, Portugal, Norway, Turkey, South Korea, Japan ,China, Vietnam, Malaysia and Thailand etc. Apart from our own Brand products, we also provide OEM service and accept customer's special orders. We will supply much better products with diversified design and professional service. We sincerely welcome the company from all over the world to cooperate with us of long-term.

Directory

Z Axis Setter Type	Pages	Edge Finder Type	Pages
NZH-50	1	ME-610 / ME-1020 / ME-420	11
NZM-50	2	ME-P1+P2 / WH-P1+P2	11
NZP-100	3	Ceramic Edge Finder	Pages
Patent Z-axis Instructions for use	4	WH-1020 / WH-1020A	10
NZD-100	5	WH-420 / WH420L/WH-1010	10
ZDE-50	6	XXR Clamping Force Gauge	12
ZDE-100	7	XXRG Clamping Force Gauge	13
ZOP-50/NZOP-50	8	HSK63A Clamping Force Gauge	14
Electronic Edge Finder	Pages	Clamping Force Gauge Instructions for use	15
OP-20/OP-32	9	55HG-BT Test Bar	16



Patented Z-axis setter

NZH-50



Model:NZH-50A
Model:NZH-50B

Height:50.00 +/-0.005mm
Weight:1.3kg
Dimension:50x63x63mm
Outer package size:100x94x81/mm



The patented Z-axis setter has been calibrated at the factory.
The lower stroke is 1mm, which is more convenient for customers.
Correction adjustment see page 4



NZH-50A
Bottom has magnets



NZH-50B
Bottom doesn't have magnets

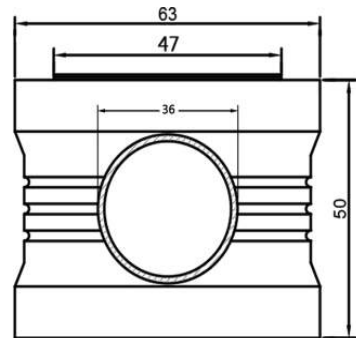
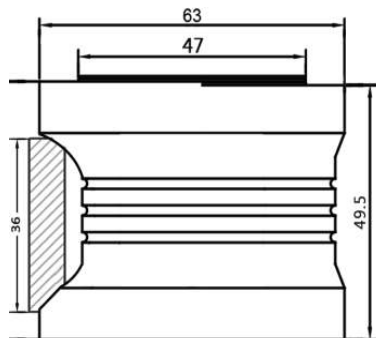

Patented Z-axis setter



NZM-50



Model:NZM-50A
Model:NZM-50B

Height:50.00 + -0.005mm
Weight:0.7kg
Dimension:50x48x48mm
Outer package size:100x94x71mm

The patented Z-axis setter has been calibrated at the factory.
The lower stroke is 1mm, which is more convenient for customers.
Correction adjustment see page 4



NZH-50A
Bottom has magnets



NZH-50B
Bottom doesn't have magnets

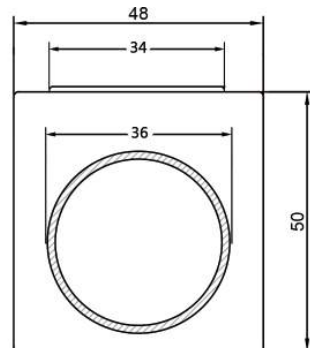
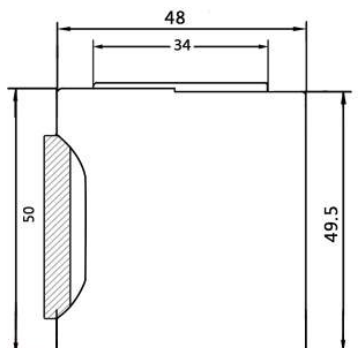



Patented Z-axis setter

NZP-100



Model:NZP-100A
Model:NZP-100B

Height:100.00 +/-0.005mm
Weight:1.7kg
Dimension:100x48x48mm
Outer package size:130x100x71mm

The patented Z-axis setter has been calibrated at the factory.
The lower stroke is 1mm, which is more convenient for customers.
Correction adjustment see page 4



NZP-100A
Bottom has magnets



NZP-100B
Bottom doesn't have magnets

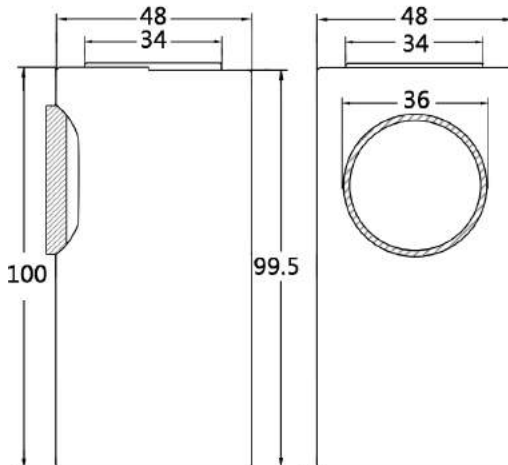

Instruction Manual of patented Z Axis Setter



NZH-50

NZM-50

NZP-100



1. Rotate the dial and make zero to the top.



2. Place the parallel bar on the Z-axis setter and press it.



3. Fix the pointer to zero with 2.5mm hex wrench.



4. Flip to the bottom of device, adjust the pointer to zero with 4mm hex wrench.



The method of resetting and cleaning:

The device might be stuck due to damage caused during the shipping. Once the top of the device was stuck, please use the 4mm (or less) rods and have a nudge into the hole a few times.



Patented Z-axis setter

NZD-100

Model:NZD-100A

Height:100.00 +/-0.005mm

Weight:1.8kg

Dimension:62x50x100mm

Outer package size:130x100x71/mm



The patented Z-axis setter has been calibrated at the factory.
The lower stroke is 1mm, which is more convenient for customers.

Fig 1. If the pointer is not at zero, press the parallel block on the standard surface to check if the pointer is zeroed.

Fig 2. Calibrate with a 2.5 hex wrench to zero the pointer

Fig 3. Use a 4mm hex wrench to adjust the touch plate if the touch plate is not at zero or you want to adjust it's height.



圖1



圖2



圖3

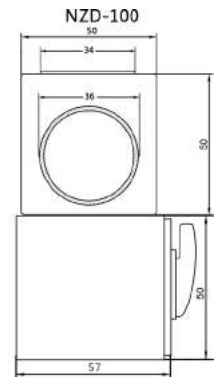
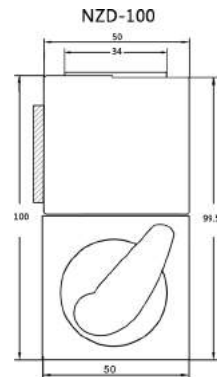

微小徑專用 Z軸設定器



ZDE-50

Model:ZDE-50A

Model:ZDE-50B

Height:50.00 +-0.005mm

Weight:0.8kg

Dimension:40x50x50mm

Outer package size:100x94x71/mm

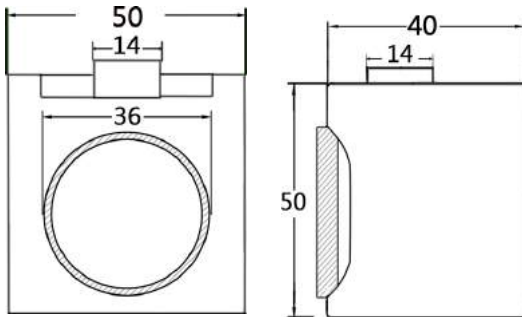

Fig1



Fig2



Fig3



Fig4

1. Place the parallel bar on the Z-axis setter and press it.

2. Rotate the dial and make zero to the pointer.

3 Take away parallel bar.

4. Put the z-axis setter on the workpieces, then push the cutter forward slowly until it reaches to 0, which is the right position .

CE

微小徑專用 Z 軸設定器

ZDE-100

Height:100.00 +/-0.005mm
Weight:1.75kg
Dimension:50x57x100mm
Outer package size:130x100x71mm

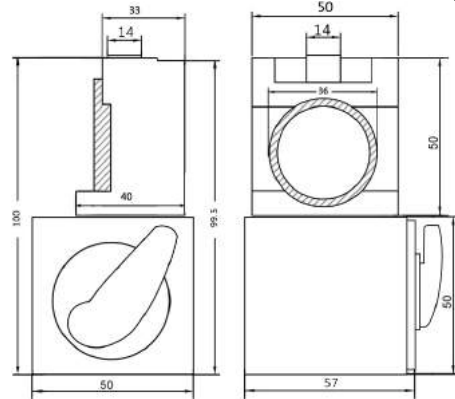

CE

ZDE-100B

Height:100.00 +/-0.005mm
Weight:1.75kg
Dimension:50x48x100mm
Outer package size:130x100x71mm
Bottom doesn't have magnets

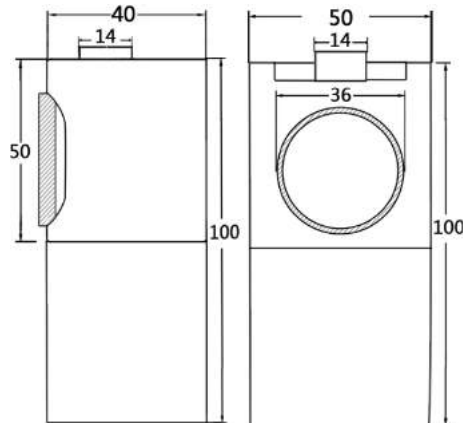

光電式 Z軸設定器



Model:ZOP-50

Machines need to be conductive before use.

Height:50.00 \pm -0.005mm
Weight:0.7kg
Dimension:50x54x54mm
Outer package size:100x94x71mm
Batteries: LR44/A76/G13 x 2PCS

Model:NZOP-50

Machines are not conductive can also be used.

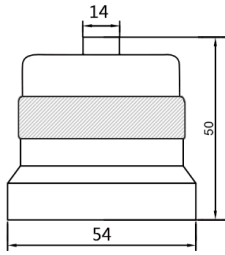

Bottom have magnetic



Internal conductor



This photoelectric Z-axis setter is a high-precision product, and the accuracy of the vernier caliper detection is not applicable.



(Fig:1)



(Fig:2)



(Fig:3)

1. Turn the handwheel (in μm) forward to the device and contact it slowly.Slowly contact the device (light up) (Fig:1)
 2. Move backward (light out) (Fig:2) The point of light-out is the correct position, you need to repeat above two steps several times in order to get the accuracy.
 3. Side detection: use the top of milling cutter to contact the bottom.
- Make sure the batteries have power before using.



Electronic - Edge Finder

Probe accuracy: 10mm / $\pm 0.005\text{mm}$

OP-20 weight:0.20kg

OP-32 weight:0.43kg



OP-20

light



OP-20B

light+sound



OP-32

light



OP-32B

light+sound

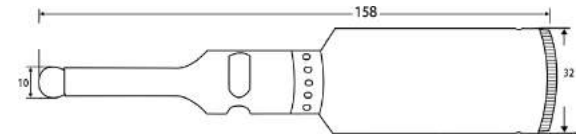
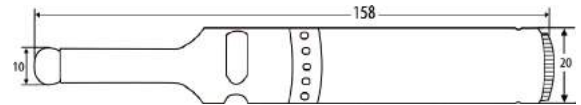

Battery : 23A 12V

1. The entire object has makes rust prevention processing, will place for a long time will not rust.
2. It's not suitably used for rotary

Usage:

FIG1. Use photoelectric edge finder handwheel please tune into the μm advance processing object

FIG2. Touching object illuminated flip rotation return,

FIG3. Not bright point is to be sought in the reference position.

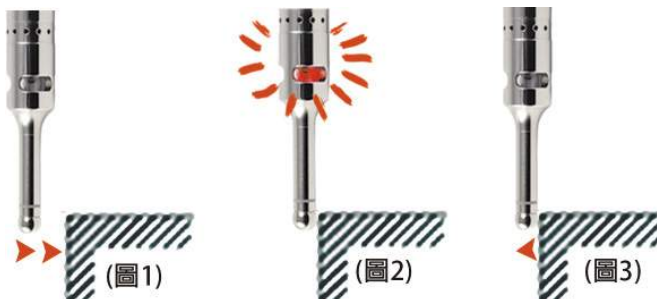

CERAMIC EDGE FINDER



Zirconia Features:

Non-magnetic, toughness good and wear-resistant, not rust, long life, It is equivalent to diamonds

Probe accuracy: $\pm 0.005\text{mm}$

WH-1010

weight:0.036kg



WH-1020A

weight:0.052kg

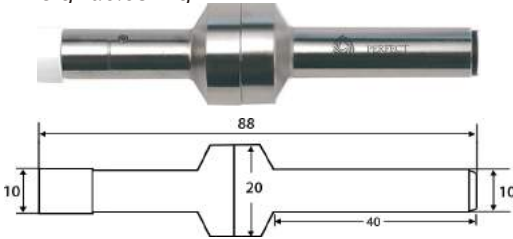

WH-1020

weight:0.052ka

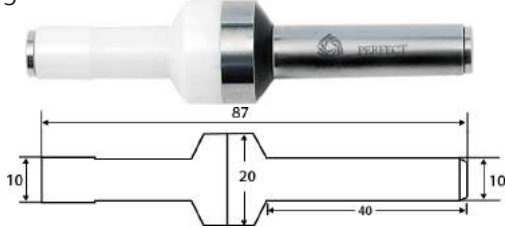

WH-420

weight:0.056kg

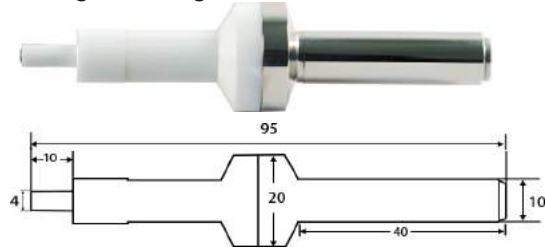

WH-420L

weight:0.056kg

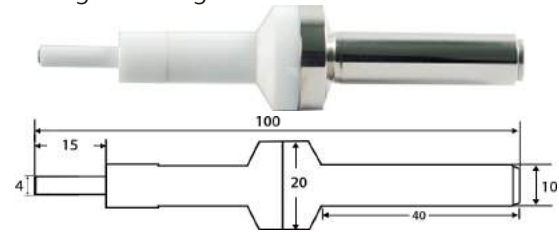

Our company use the great zirconia for ceramic raw materials. It's totally different from the other poor quality ceramic. Although it looks similar, but the life is a big difference.

You have to wisely to choose !

"A" is Perfect Technology's zirconia ceramic features: pure white, high hardness and toughness.

"B" is poor quality ceramic easily crack and color close to yellow

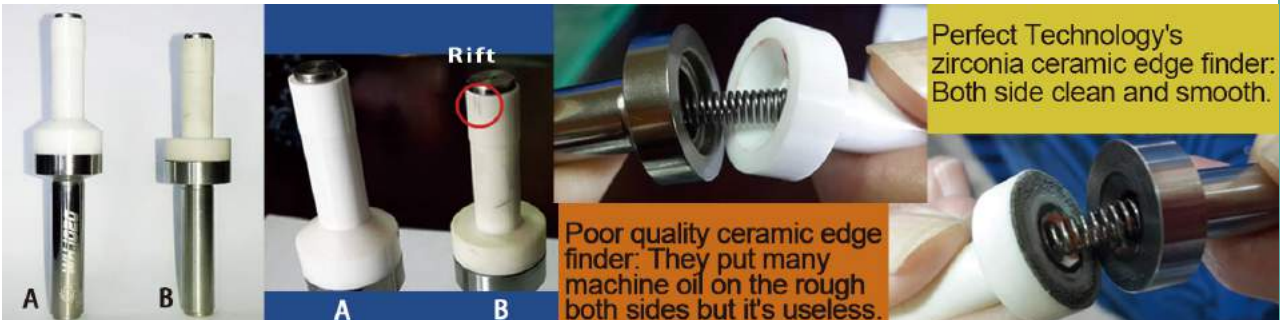

Perfect Technology's zirconia ceramic edge finder: Both side clean and smooth.

Poor quality ceramic edge finder: They put many machine oil on the rough both sides but it's useless.



EDGE FINDER

ME-610

weight:0.036kg

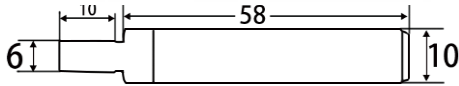

Probe accuracy: $\pm 0.005\text{mm}$
HRC58~60

ME-1020

weight:0.052kg

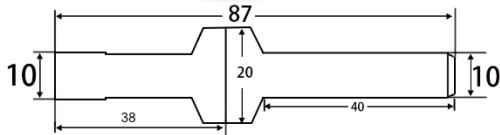

ME-420

weight:0.052kg

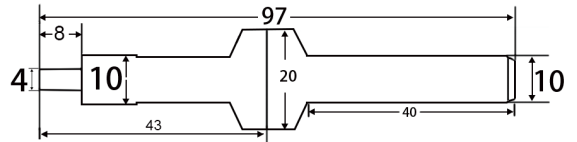

EDGE FINDER



ME-P1

weight:0.075kg

Probe accuracy: $\pm 0.005\text{mm}$
HRC58~60



ME-P2

weight:0.044kg



ME-P2C

weight:0.044kg



WH-P1

weight:0.075kg



WH-P2

weight:0.044kg

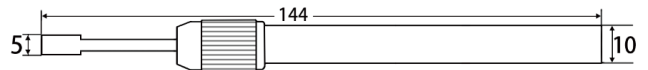

ME-P1

WH-P1

ME-P2

WH-P2



ME-P2C

WH-P2C



A hydraulic spindle Rally



XXR-BT30

Model	d1	d2	Measuring range	weight kg
BT30-45°	7	11	0~60kg tolerance ±0.1KG	4.3KG
BT30-60°	7	11		
BT30-90°	7	11		
JIS6339-30	8	12	0~150kg tolerance ±2.5KG	
ISO30	9	13		
DIN30	9	13		
SK30	9	13		

30 dynamometer meter can be selected 0~60kg or 0~150kg, the larger the gauge number, the larger the tolerance
In order to provide better service, the 30 rally meter has two options to install.

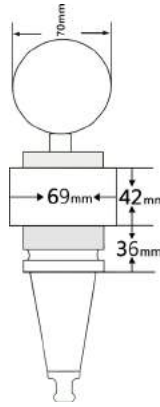

XXR-BT40

Model	d1	d2	Measuring range	weight kg
BT40-45°	10	15	0~150kg tolerance ±2.5KG	4.4KG
BT40-60°	10	15		
BT40-90°	10	15		
CAT40*45°	10	15		
CAT40*60°	10	15		
CAT40*90°	10	15		
ISO40-A	14	19		
ISO40-B	13	19		
MAZAK-40	12	19		
JIS6339-40	14	19		
DIN40	14	19		
SK40	10	15		

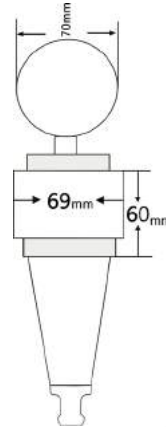

XXR-BT50

Model	d1	d2	Measuring range	weight kg
BT50-45°	17	23	0~350kg tolerance ±5.5KG	6.8KG
BT50-60°	17	23		
BT50-90°	17	23		
CAT50*45°	17	23		
CAT50*60°	17	23		
CAT50*90°	17	23		
ISO50	21	28		
MAZAK-50	21	29		
JIS6339-50	21	28		
DIN50	21	28		
SK50	17	23		

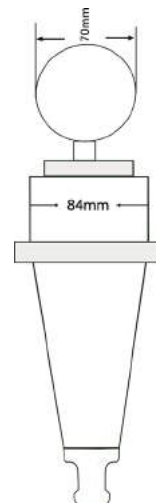

Digital Spindle Force Dynamometer

XXRG-BT30

Model	d1	d2	Measuring range	weight kg
BT30-45°	7	11	0~70bar tolerance ±0.5KG	4.3KG
BT30-60°	7	11		
BT30-90°	7	11		
JIS6339-30	8	12	0~100bar tolerance ±1.0KG	
ISO30	9	13		
ISO30-R3	8	12		
DIN30	9	13		
SK30	9	13		

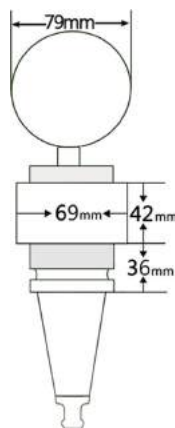

XXRG-BT40

Model	d1	d2	Measuring range	weight kg
BT40-45°	10	15	0~250bar tolerance ±2.0KG	4.4KG
BT40-60°	10	15		
BT40-90°	10	15		
CAT40*45°	10	15		
CAT40*60°	10	15		
CAT40*90°	10	15		
ISO40-A	14	19		
ISO40-B	13	19		
MAZAK-40	12	19		
JIS6339-40	14	19		
DIN40	14	19		
SK40	10	15		

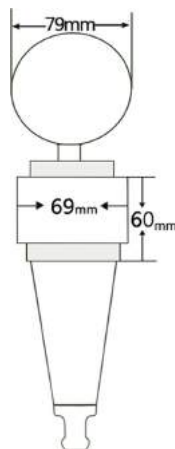

XXRG-BT50

Model	d1	d2	Measuring range	weight kg
BT50-45°	17	23	0~400bar tolerance ±3.5KG	6.8KG
BT50-60°	17	23		
BT50-90°	17	23		
CAT50*45°	17	23		
CAT50*60°	17	23		
CAT50*90°	17	23		
ISO50	21	28		
MAZAK-50	21	29		
JIS6339-50	21	28		
DIN50	21	28		
SK50	17	23		

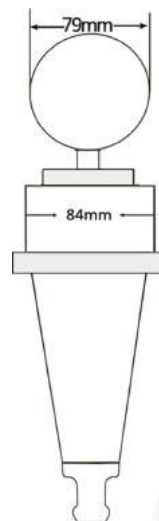

1 bar=1.02kg/cm²

Spindle Force Dynamometer



XXR-HSK63A



XXRG-HSK63A

Model	Measuring range	weight kg
XXR-HSK63A	0~150kg tolerance±2.5KG	5.3KG
XXRG-HSK63A	0~250bar tolerance±2.0KG	5.3KG

1 bar=1.02kg/cm²



Instruction Manual Spindle Force Dynamometer

a: Check if the pre-pressure is in the available condition before using.
Inspection methods:

1. Pointer is not at zero, and there is left pre-pressure
2. Manually check the pressure gauge and if the body turns if so, it means there is left pre-pressure. Otherwise, if don't, that means there is no pre-pressure.



Please confirm that the pointer is pointing to greater than 0

b: Method of reloading pre-pressure of dynamometer

1. Remove the screw B.
2. Loosen the pull stud A and loosen it again.
3. Push the pull stud A inwards (so that the oil level is reduced).
4. Fill R68 hydraulic fluid from hole B and then tighten the screw B.
5. Tighten the pull stud A. In the same time, Pointer C will be moving upward. As the pull stud A is fully tightened, the proper pressure indication will be between 10 to 30kg. If it is over 30kg, loosen Screw B and let the indication be 10 to 30kg

c: Method of dynamometer dial indicator reading

1. The inner area of the dynamometer 10.00875 mm², so when the indication times 10 is the correct pulling force.
2. An unit of dynamometer equals to 10kg
3. The digital dynamometer uses the Newton as 1 unit. (1kg = 9.8 N)

d: Method of pull stud replacement

1. Use the adjustable wrench to clamp the seat of "D"
2. Turn the A lever ("D" to hold)
3. Replace the new lever A and lock it again.
4. Check the preload again, if the preload is normal, you can continue to use it.

Conversion:

$$1 \text{ kg/cm}^2 = 10\text{kg} = 100 \text{ N}$$

$$\text{E.g: } 25\text{kg/cm}^2 = 250\text{kg} = 25000 \text{ N} = 25\text{KN}$$



Method of pull stud replacement



Screw thread 1/4PT

Instruction Manual Digital Spindle Force Dynamometer

a: Pull force count explicit return to zero setting method

1. Turn the A rod to a loose turn so that it has no pressure.
2. Turn on (ON/OFF button) and press and hold (Light/P-H button)
3. Enter the mode setting, there will be a flashing number, press (REST button) Set to "9", press (Light/P-H) to enter standby time Press (REST) to set to "5", then press (Light/P-H) twice. Will be automatically set to zero,
4. Press (ON/OFF) again to select the unit.
5. Tighten the A-pull rod again. At this time, the pressure value will go up. Please stay at the most appropriate pre-pressure value indicating that it should be between 5kg.



2.



3.

PS. To change the settings again, you have to wait for the shutdown before you can make settings.

b: pull force counting explicit fueling method

1. First remove the plug from the B
2. Turn the "A" Pull studs to loose
3. Push the A rod inward again (to make the oil chamber oil level retract)
4. Fill the R68 hydraulic oil from the B hole and lock the rear plug.
5. "A" Pull studs can be pressurized to about 5KG.

c: Method of pull stud replacement

1. Use the adjustable wrench to clamp the seat of "D"
2. Turn the "A" Pull studs ("D" to hold)
3. Replace the new Pull studs "A" and lock it again.
4. "A" Pull studs can be pressurized to about 5KG.



1 bar=1.02kg/cm²

The digital spindle tensiometer has been corrected to zero before leaving the factory. Do not press REST again. If you want to press REST, you need to turn Pull studs "A" studs to loose.

The above value is based on the PMC spindle dynamometer specification of Taiwan Precision Machinery R&D Center.

Test Bar

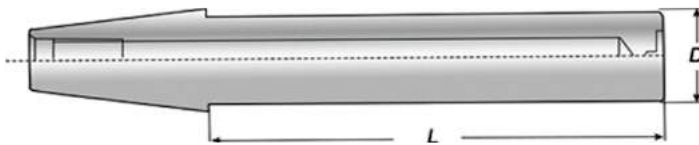

Test arbor is used to measure the runout of machine spindle. Taper Contant > 85%

Order no	D	L	Roundness	Concentricity	Package weight
55HG-BT30	30	250	< 0.003	<0.005	3.5
55HG-BT40	40	300			4.7
55HG-BT50	50	300			6.5

www.perfect-cnc.com



蒲菲科技有限公司
PERFECT TECHNOLOGY CO., LTD.

 台中市大甲區大智街169號
No.169, Dazhi St., Dajia Dist., Taichung City 437, Taiwan

 886-426865253

 886-4-26882279

 s26865253

 info@perfect-cnc.com