

OVERLOAD PROTECTOR
超負荷保護裝置



SANDSUN ISO 9001 CE

MANAGING PHILOSOPHY

Moderate & Reliable Aggressive & Creative
Demanding for Perfection Constant Operation

QUALITY POLICY

Quality Stability Customer Satisfaction

經營理念

穩健踏實 精進創新 止於至善 永續經營

品質政策

品質穩定 客戶肯定

山田順精機股份有限公司

SANDSUN PRECISION MACHINERY CO., LTD.

台灣省彰化縣大村鄉中山路三段57巷7號
NO.7, LANE 57, SEC 3, CHUNG-SHAN RD., DAH-TSUEN,
CHANG-HWA, TAIWAN.

E-mail: sa2@sandsun.com.tw (台灣)

sa3@sandsun.com.tw (abroad)

sa4@sandsun.com.tw (abroad)

TEL: +886-4-8536688 FAX: +886-4-8536699

山田順精密機械(蘇州)有限公司

SANDSUN PRECISION MACHINERY (SUZHOU) CO., LTD.

江蘇省蘇州市吳中區角直鎮楓庄路
FENGZHUANG ROAD, LUZHI TOWN, WUZHONG DISTRICT,
SUZHOU CITY, JIANGSU, CHINA
E-mail: sandsun_sz@126.com
TEL: 0512-66026635 FAX: 0512-66026637

東莞服務處

東莞市虎門鎮東風管理區東北村新區二路
TEL: 0769-85569867 FAX: 0769-85569867



2014.02 DESIGNED BY SANDSUN 886-4-2296-5269

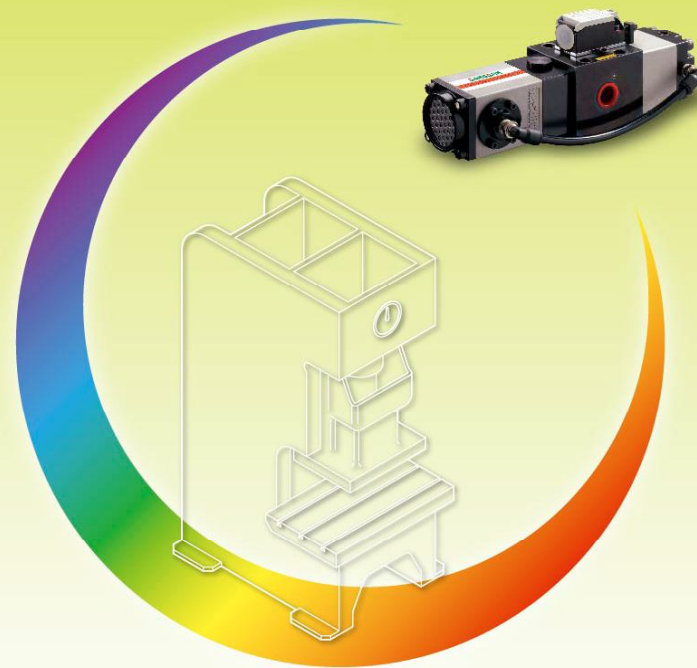

OVERLOAD PROTECTOR 超負荷保護裝置 系列產品



VA06



VA08、12



VA20



VS06



VS08、10、12



VA-763



VS-763C



VA20-1-PB-1-20L



VA20-2-PC-2-45L

Function

- Overload Protector is equipped in Press machine to check hydraulic pressure of cylinder inside the slider.
- If happen overload, the hydraulic pressure of cylinder will be released immediately within 3/1000 seconds.
- When happen overload, in order to protect the press and die, the press will stop working immediately after receiving the signal from limit switch.
- After happen overload, the air will drive hydraulic pump to supply normal working pressure immediately and the press can work normally.
- It has pressure control valve inside of overload protector, which can adjust hydraulic pressure automatically and eliminate the impact of rising pressure (which cause by oil temperature rise) in pressing process.
- May select different types of components and control units base on the different types and specifications of press machines.

功能

- 超負荷保護裝置安裝使用於沖床上，用以檢知滑塊油壓缸內部的超負荷油壓壓力。
- 當超負荷情形發生時，油壓壓力能在千分之三秒內迅速被洩放。
- 當超負荷發生時，微動開關產生電氣訊號，通知沖床緊急停止運轉，以保護沖床和模具。
- 超負荷發生之後，由空氣驅動油壓泵浦，快速補足油壓缸的正常工作壓力，使沖床能立即正常操作。
- 超負荷保護裝置內部具有恆壓控制閥，能自動調節油壓壓力，可消除沖床在沖壓過程中，因油溫上升時，而產生壓力上升所受的影響。
- 可依不同沖床型式、規格，搭配所需零組件及控制單元。

Model selection 型式選用：V 1 2 3 4 - 5 6 7 - 8

1	Control type 控制方式	A : Air type / 氣壓式 S : Spring type / 彈簧式				
2	Suitable for capacity of press 適用沖床噸數	Under 200 tons	06 : Small type / 微小型 08 : Standard type / 標準型 10 : Large flow type / 大流量型			
		200-600 tons	12 : Standard type / 標準型			
3	Ratio of pump discharge pressure 泵浦吐出壓力倍數	Model/型式	06	08	10	12
		None or A	22 Ratio	22 Ratio	22 Ratio	22 Ratio
		M	35 Ratio	32 Ratio	32 Ratio	34 Ratio
4	Design No. 設計變更碼	Empty : First edition / 空白 : 第一版 A-Z : Revise edition / A-Z : 變更碼				
5	Ratio of overload pressure 超負荷壓力倍數	5 : x 50 Ratio 7 : x 70 Ratio 9 : x 90 Ratio				
6	Limit switch type(Page 9) 微動開關型式(參P9)	2 : NO type 6 : NC type				
7	Volume of oil tank(Liter) 油箱容積	0 : None 1 : 1.2L 3 : 4L 5 : 8L				
8	Pressure setting value(kgf/cm ²) 超負荷壓力設定值	VA Model : None VS Model : ex. 3 0 0 is 300kgf/cm ²				

- Model selection for over 600 tons press machine, please refer to Page 7.
- Model selection of control unit, please refer to Page 6.
- Ratios in column 3 5 is indicated the air pressure ratios.
- Hydraulic oil : ISO-VG-32 or equivalent
- 600T 以上沖床型式選用請參閱 P7
- 含控制單元之型式選用請參閱 P6
- 3 5 之倍數為輸入空氣壓力之倍數
- 使用液壓油 : ISO-VG-32

For Press under 200 tons / 200 噸以下沖床適用

Model : VA 06、08

06 Small type / 微小型

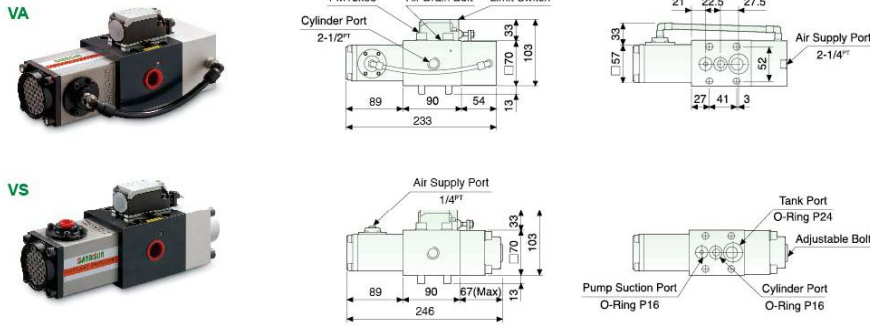

Model/型式	Releasing flow rate 洩放流量(cm³/sec)	Area of orifice 制流孔面積(cm²)	Pressure setting method 壓力設定方式	Pressure setting range 設定範圍(kgf/cm²)	Air supply 空氣壓力(kgf/cm²)
Air type	VA06□□-5□0	15500	Air pressure x 50 ratio	150-250	3-5
	VA06□□-7□0	13000	Air pressure x 70 ratio	210-350	
	VA06□□-9□0	11500	Air pressure x 90 ratio	270-450	
Spring type	VS06□□-5□0	15500	Spring Adjustment	150-250	
	VS06□□-7□0	13000		210-350	
	VS06□□-9□0	11500		270-450	

- Air consumption/空氣消耗量 : 0.37 Nm³/min
- Max noise/最大音量 : 83 dB

08 Standard type / 標準型

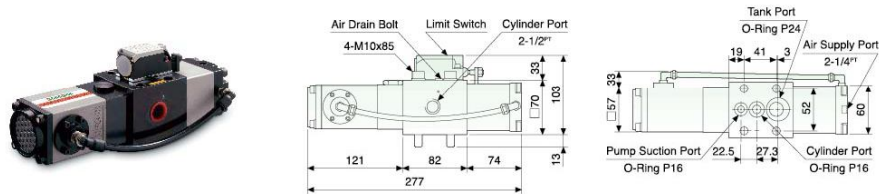

Model/型式	Releasing flow rate 洩放流量(cm³/sec)	Area of orifice 制流孔面積(cm²)	Pressure setting method 壓力設定方式	Pressure setting range 設定範圍(kgf/cm²)	Air supply 空氣壓力(kgf/cm²)
Air type	VA08□□-5□0	15500	Air pressure x 50 ratio	150-250	3-5
	VA08□□-7□0	13000	Air pressure x 70 ratio	210-350	
	VA08□□-9□0	11500	Air pressure x 90 ratio	270-450	

- Air consumption/空氣消耗量 : 0.27 Nm³/min
- Max noise/最大音量 : 77 dB

For Press under 200 tons / 200 噸以下沖床適用

Model : VS 08、10

08 Standard type / 標準型

10 Large Flow type / 大流量型

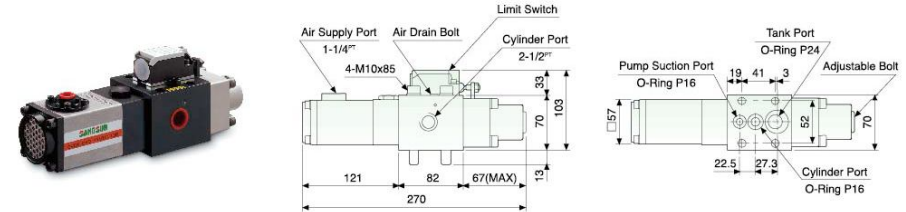

Model/型式	Releasing flow rate 洩放流量(cm³/sec)	Area of orifice 制流孔面積(cm²)	Pressure setting method 壓力設定方式	Pressure setting range 設定範圍(kgf/cm²)	Air supply 空氣壓力(kgf/cm²)
Spring type	VS08□□-5□0	15500	Spring Adjustment	150-250	3-5
	VS08□□-7□0	13000		210-350	
	VS08□□-9□0	11500		270-450	
	VS10□□-7□0	18000		210-335	
	VS10□□-9□0	14500		270-450	

- Air consumption/空氣消耗量 : 0.27 Nm³/min
- Max noise/最大音量 : 77 dB

Include Oil Tank / 含油箱

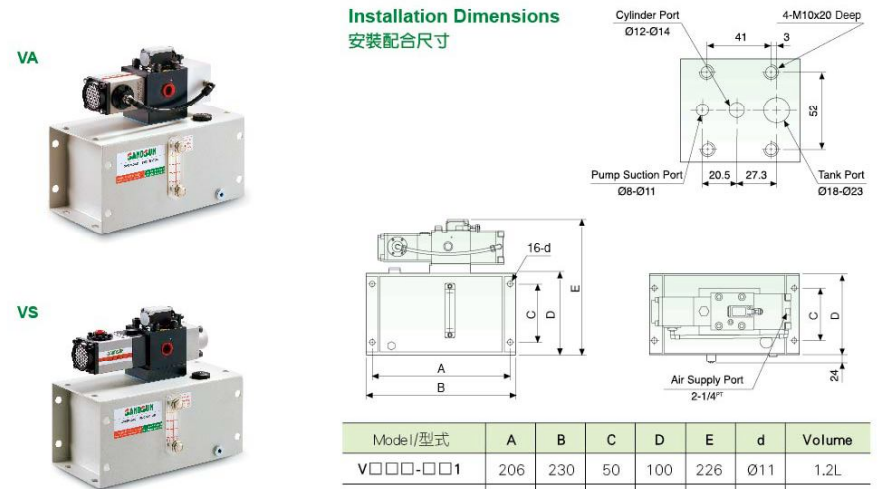

Model/型式	A	B	C	D	E	d	Volume
V□□□-□□1	206	230	50	100	226	Ø11	1.2L
V□□□-□□3	285	310	80	150	276	Ø13	4.0L
V□□□-□□5	355	380	130	200	326	Ø13	8.0L

For Press 200~600 tons / 200~600 噸沖床適用

Model : VA VS 12

12 Standard type / 標準型

VA

VS

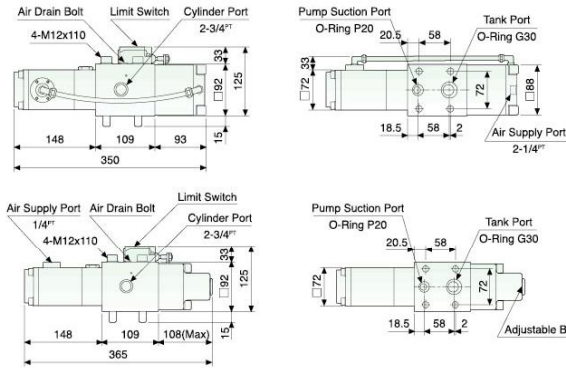

Model/型式	Releasing flow rate 洩放流量(cm³/sec)	Area of orifice 制流孔面積(cm²)	Pressure setting method 壓力設定方式	Pressure setting range 設定範圍(kgf/cm²)	Air supply 空氣壓力(kgf/cm²)
Air type	VA12□□-5□□	39000	Spring Adjustment	150-250	3-5
	VA12□□-7□□	31000		210-350	
	VA12□□-9□□	27000		270-450	
Spring type	VS12□□-5□□	39000	Spring Adjustment	150-250	
	VS12□□-7□□	31000		210-350	
	VS12□□-9□□	27000		270-450	

- Air consumption/空氣消耗量 : 0.31 Nm³/min
- Max noise/最大音量 : 77 dB

Include Oil Tank / 含油箱

VA

VS

Installation Dimensions
安裝配合尺寸

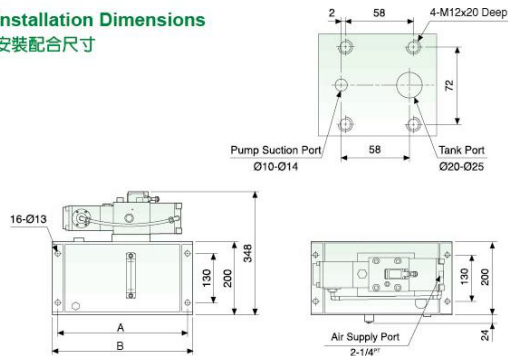

Model/型式	A	B	Volume
V□12□-□□5	355	380	8.0L
V□12□-□□8	415	440	12.0L

For Press under 600 tons / 600 噸以下沖床適用

Include Control Unit / 含控制單元

Model selection 型式選用 : VA VS □□ - □□ 1 C - 2 - 3

Refer to Page 2 / 參閱P2

		3 : 4L	5 : 8L
1	Volume of oil tank(Liter) / 油箱容積	4 : 6L	8 : 12L
2	Electronic control voltage / 電壓	DC24V	AC220V
3	Types of solenoid valve / 電磁閥型式	NO : Normal Open	NC : Normal Close

- Control unit : include air regulator, solenoid valve, air pressure gauge
控制單元包含 : 調壓閥、電磁閥、壓力計
- We also customize special Over load Protector & oil tank, if required, please contact us directly.
我們提供特殊規格超負荷以及大型油箱客製化服務

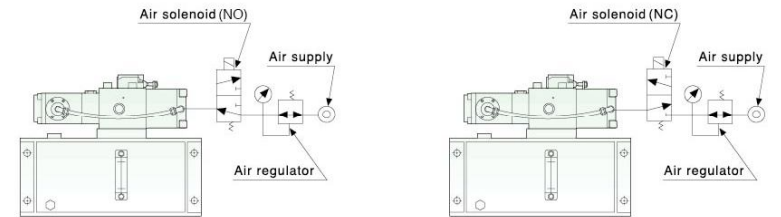

VA

VS

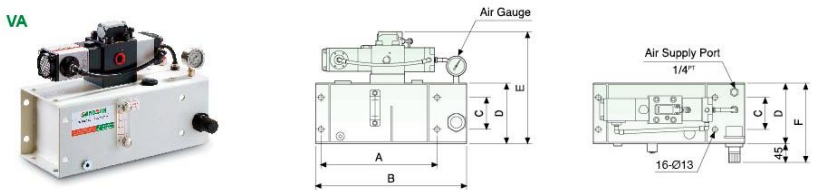

Model/型式	A	B	C	D	E	F	Volume	
VA 06	3C	285	370	80	150	276	195	4L
VS 10	4C	350	440	100	150	276	195	6L
	5C	355	440	130	200	326	245	8L
VA 12	5C	355	440	130	200	348	245	8L
	8C	415	500	130	200	348	245	12L

For Press over 600 tons / 600 噸以上沖床適用

Model : VA20



Model selection 型式選用 : VA20-**1**-**2**0-**3**-**4**-**5****6**-**7**-**8**L
 Overload valve / 超負荷閥 Pump / 泵浦

1	Ratio of overload pressure 超負荷壓力倍數	4 : x 40 Ratio 5 : x 50 Ratio 7 : x 70 Ratio 9 : x 90 Ratio																																																												
2	Limit switch type(Page 9) 微動開關型式(參P9)	2 : NO type 6 : NC type																																																												
3	Quantity of Flange model for Cylinder Port (法蘭型式和數量) Close : 密封型 PT : 管牙型 B : Welding 焊接型	<table border="1"> <tr> <th>Flange model</th> <th>Code</th> <th>0</th> <th>1</th> <th>2</th> <th>3</th> <th>4</th> <th>5</th> <th>6</th> <th>7</th> </tr> <tr> <td>Close</td> <td></td> <td>1</td> <td>1</td> <td></td> <td></td> <td>1</td> <td>1</td> <td></td> <td></td> </tr> <tr> <td>1B(Ø34.5)</td> <td></td> <td>1</td> <td></td> <td>2</td> <td></td> <td></td> <td></td> <td></td> <td></td> </tr> <tr> <td>1PT</td> <td></td> <td></td> <td>1</td> <td></td> <td>2</td> <td></td> <td></td> <td></td> <td></td> </tr> <tr> <td>1-1/4B(Ø43.2)</td> <td></td> <td></td> <td></td> <td></td> <td></td> <td>1</td> <td></td> <td>2</td> <td></td> </tr> <tr> <td>1-1/4PT</td> <td></td> <td></td> <td></td> <td></td> <td></td> <td></td> <td>1</td> <td></td> <td>2</td> </tr> </table> <p style="text-align: right;">unit : pcs</p>	Flange model	Code	0	1	2	3	4	5	6	7	Close		1	1			1	1			1B(Ø34.5)		1		2						1PT			1		2					1-1/4B(Ø43.2)						1		2		1-1/4PT							1		2
Flange model	Code	0	1	2	3	4	5	6	7																																																					
Close		1	1			1	1																																																							
1B(Ø34.5)		1		2																																																										
1PT			1		2																																																									
1-1/4B(Ø43.2)						1		2																																																						
1-1/4PT							1		2																																																					
4	Quantity of Overload valve (超負荷閥數量)	1 : 1 Pcs 2 : 2 Pcs																																																												
5	Model of Pump (泵浦型式)	PB : Small Flow (20L & 30L oil tank) PC : Large Flow (45L & 60L oil tank)																																																												
6	Ratio of Pump discharge pressure 泵浦吐出壓力倍數	PB12 : 22 Ratio PB10 : 34 Ratio PC18 : 24 Ratio PC16 : 34 Ratio																																																												
7	Quantity of Pump 泵浦數量	1 : 1 Pcs 2 : 2 Pcs																																																												
8	Volume of oil tank(Liter) 油箱容積	1 : 20L 5 : 45L 3 : 30L 7 : 60L																																																												

20 Standard type / 標準型

Model/型式	Releasing flow rate 洩放流量(cm³/sec)	Area of orifice 制流孔面積(cm²)	Pressure setting method 壓力設定方式	Pressure setting range 設定範圍(kgf/cm²)	Air supply 空氣壓力(kgf/cm²)
VA20-4□0-□	96000	5.4	Air pressure x 40 ratio	120-200	3-5
VA20-5□0-□	84000	4.3	Air pressure x 50 ratio	150-250	
VA20-7□0-□	70000	3.1	Air pressure x 70 ratio	210-350	
VA20-9□0-□	60000	2.4	Air pressure x 90 ratio	270-450	

For Press over 600 tons / 600 噸以上沖床適用

Model : VA20

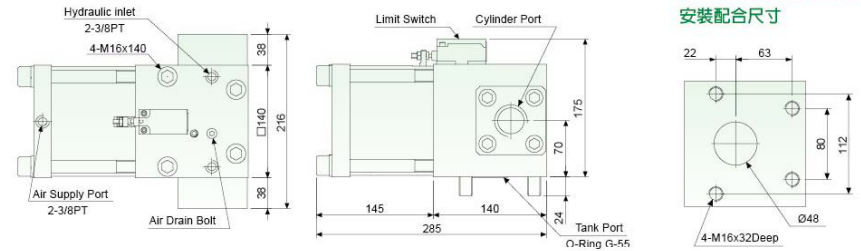

- Air driven hydraulic pump & oil tank need to be purchased separately.
氣動油壓泵浦及油箱需另購
- Model of Flage please refer to column 3 in page 7.
法蘭型式請依 3 選用

Include Oil Tank / 含油箱

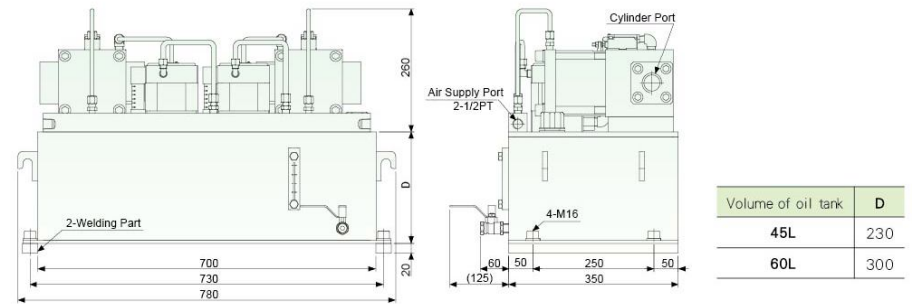
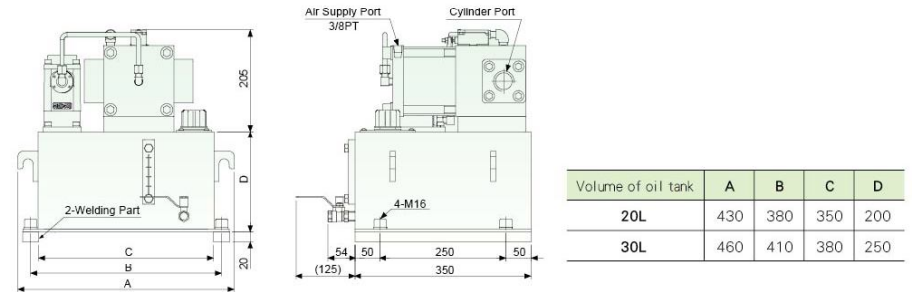

- We also customize Lager Oil tank, if required, please contact us directly.
提供客製化大型油箱，若有需要，請直接與我們聯絡

Specification / 特性對照表

Releasing Flow Rate / 洩放流量表

Ratio of overload pressure 超負荷壓力倍數	Under 200 tons			200-600 tons	Over 600 tons
	Small type 微小型	Standard type 標準型	Large Flow type 大流量型	Standard type 標準型	
	V□06	V□08	VS10	V□12	VA20
40 Ratio	—	—	—	—	96000
50 Ratio	15500	15500	—	39000	84000
70 Ratio	13000	13000	18000	31000	70000
90 Ratio	11500	11500	14500	27000	60000
Refer Pages 參照頁數	P3	P3、P4	P4	P5	P7

Types of Limit Switch / 微動開關型式

	During the Production 生產時	When Overload Happening 超負荷時	After overload 超負荷後
2 : NO type	OFF	ON	ON
6 : NC type	ON	OFF	OFF

Installation model / 安裝模式

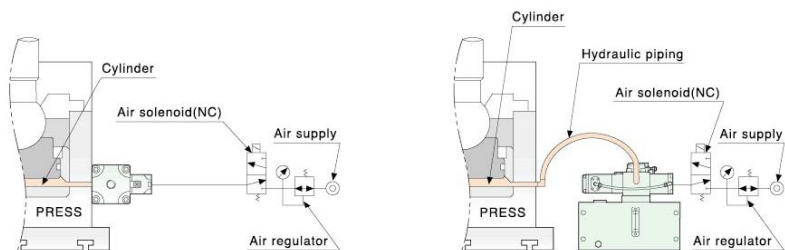

Circuit Control System / 迴路控制系統

VA type

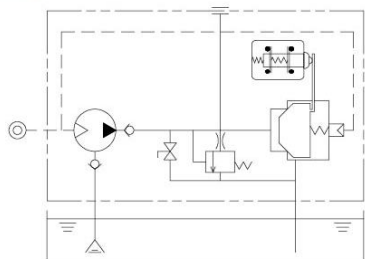

VS type

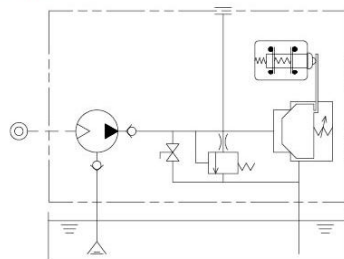

Selection Basis / 選用依據

Specification & Parameter of Press / 沖床規格參數

- F : press rated capacity 沖床能力(tons)
- S : stroke length 滑塊行程(mm)
- N : stroke per minute 每分鐘行程數(SPM)
- H : rated tonnage point 能力發生點(mm)
- D : cylinder diameter 油缸直徑(cm)
- n : cylinder number 油缸個數(pc)
- h : cylinder stroke 油缸之活塞行程(cm)

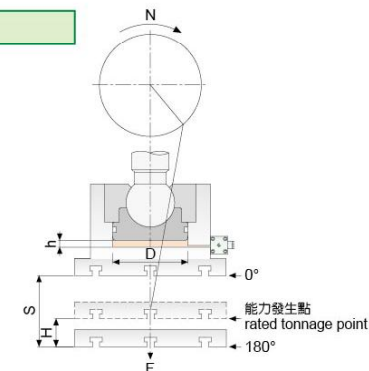

Calculation Formulas for Model Selection / 型式選用計算流程

- $A = (\pi D^2 / 4) \times n$ (cm²) cylinder area 油缸面積
- $P = F \times 110\% \times 1000 / A$ (kgf/cm²) hydraulic pressure setting of overload (VS model) 超負荷設定的油壓壓力
- $P_a = P / m$ (kgf/cm²) air pressure setting of overload (VA model) 超負荷設定的空氣壓力
- $V = N \sqrt{SH - H^2} / 87.5$ (cm/sec) drop speed of slide 滑塊下降速度
- $Q = AxV$ (cm³/sec) releasing flow rate 超負荷發生時的洩放流量
- $L \geq 4 \times Axh$ (cm³) volume of oil tank 油箱容量
- m : ratio of overload hydraulic pressure 超負荷壓力倍數
- Releasing flow rate (Q) of overload protector, which you choose has to be more than of cylinder volume.
If releasing flow rate isn't enough, please use two sets of overload protector

Example / 範例 : (model:VA(VS)08-7□□)

- F = 160 tons $A = (\pi 26^2 / 4) \times 1 = 531$ (cm²)
- S = 200 mm $P = 160 \times 110\% \times 1000 / 531 \approx 332$ (kgf/cm²)-----VS model
- N = 40 SPM $P_a = 332 / 70 \approx 4.75$ (kgf/cm²)-----VA model
- H = 6 mm $V = 40 \sqrt{200 \times 6 - 6^2} / 87.5 = 15.6$ (cm/sec)
- D = 26 cm $Q = 531 \times 15.6 = 8284$ (cm³/sec)
- n = 1 pc $L \geq 4 \times 531 \times 1 \geq 2120$ (cm³)
- h = 1 cm

Note

- Hydraulic pressure (P) and air pressure (Pa) of overload protector, should be choose as higher as possible.
(Example : P=335 kgf/cm² or Pa=4.8 kgf/cm²)
- Hydraulic piping size:

VA(VS)08 - □□□□ - □□□		VA(VS)12 - □□□□ - □□□	
Size (I.D./O.D.)	Work pressure (maxi.)	Size (I.D./O.D.)	Work pressure (maxi.)
12/18 mm	400 kgf/cm ²	14/22 mm	400 kgf/cm ²
13/18 mm	320 kgf/cm ²	16/22 mm	300 kgf/cm ²
14/18 mm	250 kgf/cm ²	18/22 mm	200 kgf/cm ²

- Inside diameter of air piping must be more than 6 mm.