

# ECSC 多功能捨棄式倒角銑刀

## Indexable-Multipurpose Chamfering Cutter



### 特色 / FEATURES :

- ◎ 一把可倒角、定點、雕刻加工完美結合的多功能切削刀具。  
A perfect multi-functional cutting tools in chamfering, spotting and engraving.
- ◎ 適用於CNC銑床、CNC車床和CNC車銑複合加工機。  
Applicable to CNC milling machine, CNC turning machine and mill-turn machine.
- ◎ 加工震動小、穩定性高。  
Less vibration and higher stability.
- ◎ 共有4個切削刃設計，降低客戶刀具使用量。  
Total 4 cutting edges for cost-effective cutting.
- ◎ 適合碳素鋼、合金鋼、不銹鋼、鑄鐵、鋁合金之應用。  
Use for carbon steels, alloy steels, stainless steels, cast iron, aluminum alloys machining.

刀尖R角0.4R

Ap(Max)  
= 5.5mm

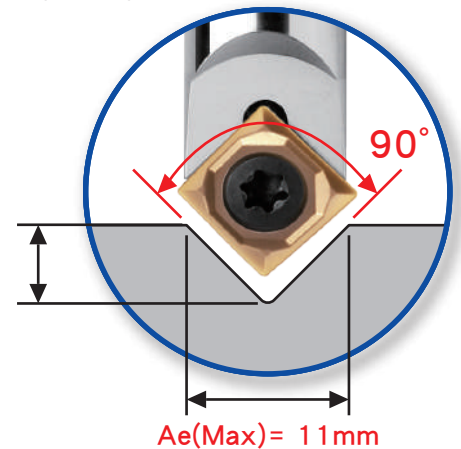

Ae(Max) = 11mm

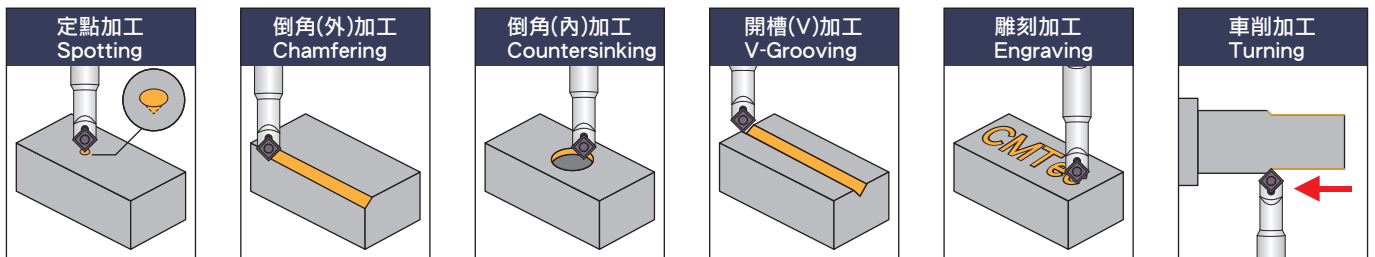

### 刀桿尺寸規格表 / HOLDER SIZE :

頂角 Top Angle	刃徑 Diameter	刃長 Cutting Length	有效長 Effective Length	全長 O.A.L.	柄徑 Shank Dia.	刀片 數量 Teeth	螺絲 Screw	螺絲 扳手 Wrench	刀桿訂購編號 Cutter Order No.
90°	13	5.5	29	100	10	1	TS3520	ETF15	ECSC09-01013-100L
90°	13	5.5	29	100	12	1			ECSC09-01013-100L-12
90°	13	5.5	29	100	16	1			ECSC09-01013-100L-16
90°	13	5.5	29	150	16	1			ECSC09-01013-150L-16

頂角 Top Angle	刃徑 Diameter	刃長 Cutting Length	全長 O.A.L.	螺紋M Thread	刀片 數量 Teeth	螺絲 Screw	螺絲 扳手 Wrench	開口 扳手 Wrench	刀頭訂購編號 Modular Head Order No.
90°	13	5.5	30	M6×1.0	1	TS3520	ETF15	TC08	HCSC09-01013

刀片 Insert	應用材質 Work Material	碳素鋼 Carbon Steels	合金鋼 Alloy Steels	調質鋼 Hardened Steels		不銹鋼 Stainless Steels	鑄鐵 Cast Iron	鋁合金 Aluminum Alloys	高溫合金 High Temp Alloys
		HRC<20	HRC20~30	HRC30~45	HRC45~55	HRC55~63	—	HRC<30	—
SCGX09T304-AG-CM10		—	—	—	—	—	—	⊙	—
SCGX09T304-FG-CM6012		⊙	⊙	—	—	⊙	⊙	⊙	⊙
SCMX09T304-SM-CM6032		⊙	⊙	⊙	○	—	⊙	—	○

# 切削條件表/ CUTTING CONDITION TABLE:

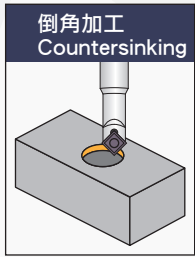

倒角加工  
Countersinking

加工材質 Material	碳素鋼 Carbon Steels	合金鋼 Alloy Steels	不銹鋼 Stainless Steels	鑄鐵 Cast Iron	鋁合金 Aluminum Alloys
工件料號 Material Code	S35C,S45C,S50C	SCM,SKT,SKD	SUS304	FC,FCD	Al 5052 / 6061 / 7075
硬度 Hardness	HRC<20	HRC20~30	-	HRC<30	-
切削速度 Vc	150~300m/min	100~250m/min	60~120m/min	150~250m/min	150~350m/min
每轉進給量 f	0.15~0.20mm/rev	0.1~0.2mm/rev	0.1~0.2mm/rev	0.15~0.25mm/rev	0.15~0.30mm/rev
切削量 Cutting Amount (mm)	Ap=0.5~1mm 	Ap=0.5~1mm 	Ap=0.5~1mm 	Ap=0.5~1mm 	Ap=0.5~1mm 

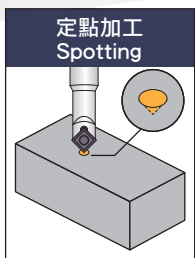

定點加工  
Spotting

加工材質 Material	碳素鋼 Carbon Steels	合金鋼 Alloy Steels	不銹鋼 Stainless Steels	鑄鐵 Cast Iron	鋁合金 Aluminum Alloys
工件料號 Material Code	S35C,S45C,S50C	SCM,SKT,SKD	SUS304	FC,FCD	Al 5052 / 6061 / 7075
硬度 Hardness	HRC<20	HRC20~30	-	HRC<30	-
切削速度 Vc	60~250m/min	50~200m/min	60~120m/min	100~200m/min	100~300m/min
每轉進給量 f	0.05~0.10mm/rev	0.04~0.06mm/rev	0.03~0.06mm/rev	0.05~0.10mm/rev	0.05~0.10mm/rev
切削量 Cutting Amount (mm)	Ap≤5.5mm 	Ap≤5.5mm 	Ap≤5.5mm 	Ap≤5.5mm 	Ap≤5.5mm 

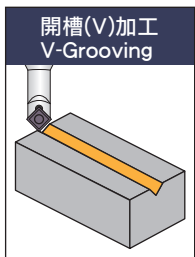

開槽(V)加工  
V-Grooving

加工材質 Material	碳素鋼 Carbon Steels	合金鋼 Alloy Steels	不銹鋼 Stainless Steels	鑄鐵 Cast Iron	鋁合金 Aluminum Alloys
工件料號 Material Code	S35C,S45C,S50C	SCM,SKT,SKD	SUS304	FC,FCD	Al 5052 / 6061 / 7075
硬度 Hardness	HRC<20	HRC20~30	-	HRC<30	-
切削速度 Vc	60~250m/min	50~200m/min	60~120m/min	100~200m/min	100~300m/min
每轉進給量 f	0.05~0.07mm/rev	0.04~0.06mm/rev	0.03~0.06mm/rev	0.05~0.07mm/rev	0.05~0.07mm/rev
切削量 Cutting Amount (mm)	Ap≤5.5mm 	Ap≤5.5mm 	Ap≤5.5mm 	Ap≤5.5mm 	Ap≤5.5mm 

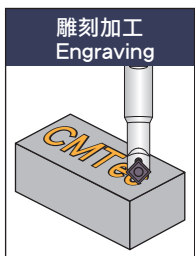

雕刻加工  
Engraving

加工材質 Material	碳素鋼 Carbon Steels	合金鋼 Alloy Steels	不銹鋼 Stainless Steels	鑄鐵 Cast Iron	鋁合金 Aluminum Alloys
工件料號 Material Code	S35C,S45C,S50C	SCM,SKT,SKD	SUS304	FC,FCD	Al 5052 / 6061 / 7075
硬度 Hardness	HRC<20	HRC20~30	-	HRC<30	-
切削速度 Vc	60~250m/min	50~200m/min	60~120m/min	100~200m/min	100~300m/min
每轉進給量 f	0.02~0.05mm/rev	0.02~0.03mm/rev	0.01~0.02mm/rev	0.02~0.05mm/rev	0.02~0.05mm/rev
切削量 Cutting Amount (mm)	Ap=0.2~1mm 	Ap=0.2~1mm 	Ap=0.2~1mm 	Ap=0.2~1mm 	Ap=0.2~1mm 