

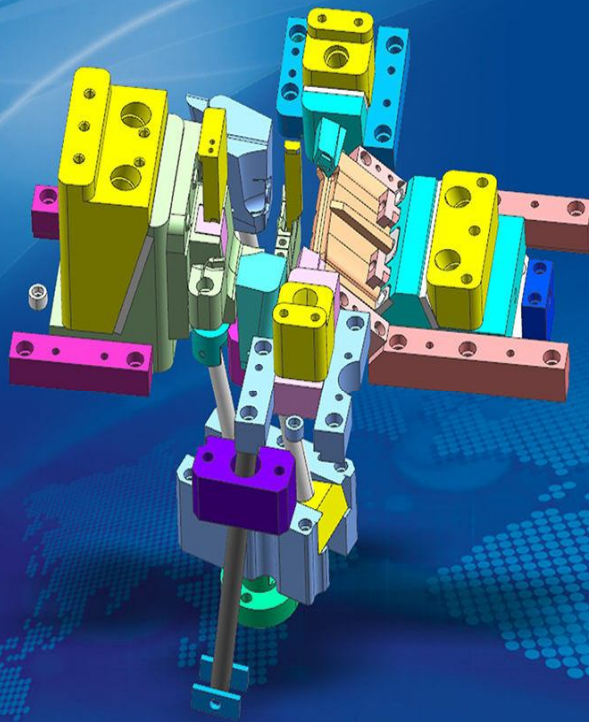

東莞市銘旺模具有限公司  
UPS MOLD CO., LIMITED.



[Http://www.upsmould.net](http://www.upsmould.net)

中国·广东  
China · Guangdong



## 公司介绍 Corporate Introduction

UPS东莞铭旺模具有限公司始创于2001年，主要致力于塑胶模具零件的研发、生产、销售、技术支持及售后服务。公司地处广东省东莞市常平镇，地理位置优越，交通十分便利。铭旺精密不断为塑胶模具零件的标准化、产业化及产品的通用性、互换性而不懈努力。

科技创新，人才为本。公司拥有多年国外工作技术团队，在信息技术高速发展的今天，企业只有不断的创新，拥有专业的设计队伍及先进的UG、Solidworks、AutoCAD设计软件以开发出更多令客户满意的产品。随着中国出口模具的蓬勃发展，为匹配出口模具的高品质、快货期的需求，自2003年开始，UPS铭旺精密全力专注汽车模具零件；于欧美亚品牌标准塑胶模具零件的中国制造与技术支持。经过几年的努力，其产品并能依循国标GB、德标DIN、美标AISI、日标JIS、等国际行业标准制作。

公司的产品主要有:汽车模具零件;斜顶、镶件、行位、铲鸡、压块、耐磨板、斜顶座、斜顶杆、模具顶针、顶针司筒，导柱导套、(高力黄铜加石墨)、模具日期章、锁模扣、限位夹、定位零件、模具气顶、二次顶出机构、加速顶出机构、斜顶装置、冷却零件、模具计数器、模具隔热板等，在产品多元化的同时，铭旺模具在生产加工能力、品质控制过程、技术解决水平、以及整体服务解决方案方面都有了很大的进步与提升，赢得了客户的认可与信赖。

随着公司的日益壮大，2006年9月，UPS铭旺模具获得了一般纳税人资格，2008年6月打造了铭旺精密及UPS Mold品牌；2008年初，公司荣获了ISO9001:2000质量标准认证并开始拓展海外市场、先后与众多知名客户建立了长期的战略合作伙伴关系，受到广大客户的一致青睐与好评。UPS铭旺愿与新老客户携手共创辉煌的明天。

正在合作的单位有:

FLEXTRONICS X 伟创力电脑(珠海)有限公司

FLEXTRONICS X 伟创力塑胶科技(深圳)有限公司

TK 深江控股 深江模具科技(深圳)有限公司

KK-MOLD 精森源模具(深圳)有限公司

ACOT 宇科模具(厦门)有限公司

GT 唯科模具(厦门)有限公司

FLEXTRONICS X 伟创力精密机械(成都)有限公司

W 志和模具塑胶(中山)有限公司

可以选用的材料: 1.1020、1.2083、1.2311、1.2312、1.2316、1.2343、1.2344、1.2510、1.2738、FDAC、SKD61、SKH51、SUJ2、H13、O1、420ESR、P20H、718H、Ampco18、8407ESR、S136ESR、DF-3、S7、635、A88、等材料。

UPS Mold Co., Limited. was established in 2001, which is mainly dedicated to the R&D, production, sales, technical supports and after-sales services. Situated in Changping Town, Dongguan City, Guangdong Province, the Company enjoys an advantageous geographical location and easy transportation access. UPS Precision has been ceaselessly striving to realize the standardization and industrialization of the plastic mold parts as well as the versatility and interchangeability of the products.

The Company has attached great importance to technological innovation and being people-oriented and it is endowed with a technical team with experience of overseas work. Amid the current era featuring high-speed technological development, through constant innovations, the Enterprise possesses a professional design team and such advanced design software as UG, Solidworks and AutoCAD. With the booming development of Chinese exports of molds, in order to cope with the needs for high quality and fast delivery for the exported molds, since 2003, UPS Mold Co., Limited. Precision has dedicated itself to the auto mold parts, and has provided Chinese manufacturing and technical supports for the standard plastic parts for the European and Asian brands. Through the endeavors of the past several years, its products have complied with such international industrial standards as GB, DIN, AISI and JIS.

The Company's main products include: auto mold parts: lift core, inserts, slides, wedge block, strip, wedge wear plate, lift core block, ejector pole, mold ejector pins, ejector sleeves, guide pillars and bushes (high-strength brass and graphite), mold date stamp, latch locks, slide retainer, locating parts, mold air valve, secondary ejectors, accelerated ejector, lift core device, cooling parts, mold shot counters and mold thermal baffles, etc. While having product diversifications, UPS Mold has also achieved great progress and upgrading in such aspects as capacity of production and processing, the process of quality as well as the solutions for integrated services, thus winning the clients' recognition and confidence.

In September 2006, with the growing of the company, UPS Mold Co., Ltd. won qualification of the general taxpayer, and in June, 2008, they cast the brands of Mingwang Precision and UPS Mold; In early 2008, the Company was awarded the ISO9001:2000 quality standard certification and began to develop the overseas markets. They have consecutively established long-term strategic cooperation relations with many famous clients and have won unanimous favorable comments from the clients. UPS Mingwang is willing to join hand in hand with the new and old clients in creating brilliant future.

The units in cooperation are:

FLEXTRONICS X Flextronics Computers (Zhuhai) Co., Ltd.

FLEXTRONICS X Flextronics Plastic Technology (Shenzhen) Co., Ltd.

TK 深江控股 Dongjiang Mold Technology (Shenzhen) Co., Ltd.

KK-MOLD JingsenYuan Mold (Shenzhen) Co., Ltd.

ACOT Yuke Mold (Xiamen) Co., Ltd.

GT 唯科 Weike Mold (Xiamen) Co., Ltd.

FLEXTRONICS X Flextronics Precision Machinery (Chengdu) Co., Ltd.

W Zhihe mold and plastic (Zhongshan) Co., Ltd.

The optional materials include: 1.1020、1.2083、1.2311、1.2312、1.2316、1.2343、1.2344、1.2510、1.2738、FDAC、SKD61、SKH51、SUJ2、H13、O1、420ESR、P20H、718H、Ampco18、8407ESR、S136ESR、DF-3、S7、635、A88 and so on.

## 组织架构 Organizational Chart



## 公司资质 Company qualification



## 销售网络 Sales Network



## 人力资源 Human Resource

- 行政管理 Administration ■
- 生产团队 Production Team ■
- 工程技术 Engineering Department ■
- 销售团队 Sales & Marketing Department ■

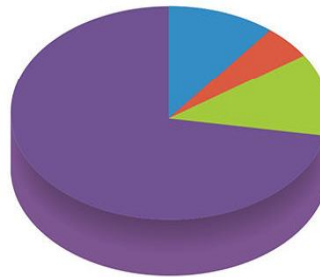

## 可信赖的专业团队 Reliable Expert Team

UPS用贴心的服务、优质的产品、诚信的经营，构建了UPS这支无坚不摧的团队。UPS一直秉承以人为本，卓越品质，一流服务，共享成功的理念，赢得了广大客户的认可，建立了更好的发展基础，在公众中树立了良好的品牌形象。

With attentive service, quality products and business integrity, UPS has established an impregnable team of professional expertise. Based on the concept of people orientation, excellence in quality, first-class service and success sharing, UPS has won the recognition of our vast number of customers, built a strong foundation for development, and established an excellent public brand image.



# 東莞市銘旺模具有限公司 UPS MOLD CO., LIMITED.

## 强大的技术力量 Strong Technical Capabilities



UPS拥有强大的技术力量、完善的工艺设备、专业的科技开发队伍、严格的产品检测制度，其各项技术指标均已达到行业先进水平，我们一流的产品质量、一流的售后服务深受广大用户信赖。我们将以开拓进取、创新求精为目标。通过先进的技术，科学的设计，缜密的创造及人性化的服务，赢得客户的拥戴与认可，做同类产业中的佼佼者。

UPS possesses immense technical capabilities, comprehensive technical facilities, a professional technology development team, and a stringent product testing system. Our technical standards have attained advanced levels in the industry; and our first-class product quality and after-sales service has won the trust of our vast number of users.

We will aim to continuously forge ahead with innovation. Through advanced technology, scientific design, precision manufacturing and people-oriented service, UPS will continue to win the support and recognition of our customers and to be the leader in the industry.

## 产品定位和分类 Product Positioning and Classification

UPS有限公司定位于生产和销售高精度的订造非标模具零件，以及与之配套的模具配件和模具钢材，至力于为客户提供一条龙服务，及成为客户战略合作伙伴。

UPS majors in manufacturing and sales of high-precision mould base, including related mold components and materials. We are dedicated to support our customer with one-stop service.

序号NO.	类型 Type	种类 Classification
1	精密模具配件 Precision Tooling Component	Lifter/wear plate/silde/Press plate/locking heel
2	精密模板 Precision Plates	注塑模架 Plastic Mould Base 压铸模架 Die-Casting Mould Base 冷冲模架 Cold-Punching Mould Base
3	模具钢材 Mould Steel	UPS2085、2083、718H、738H、P20等模具钢材

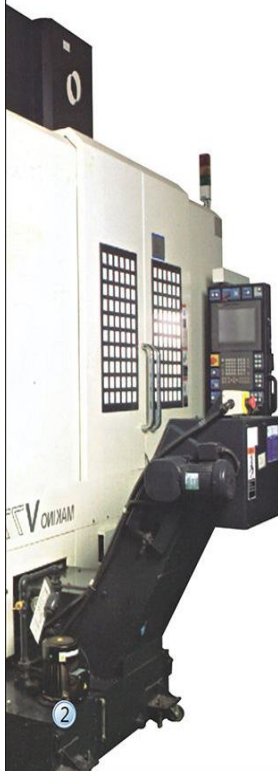

» Lifter insert

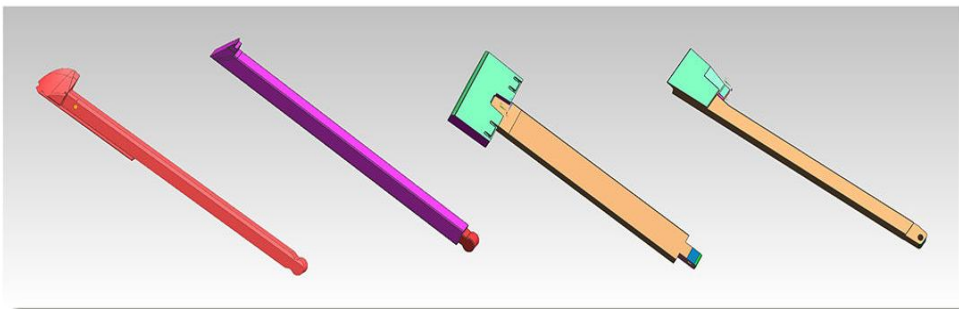
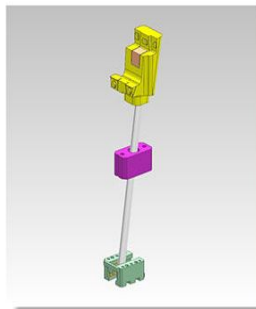
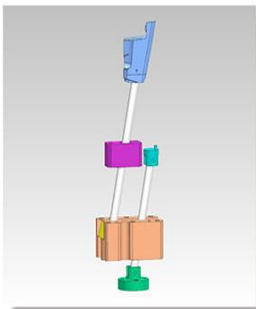
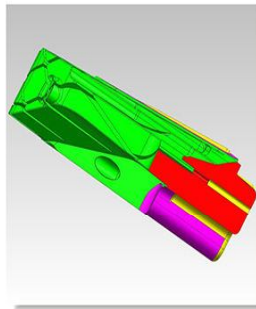
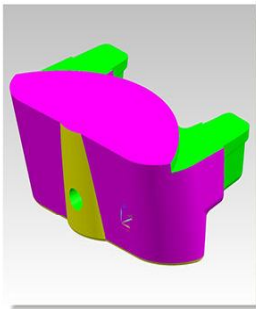
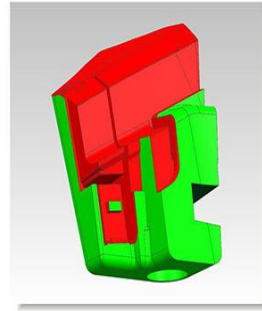
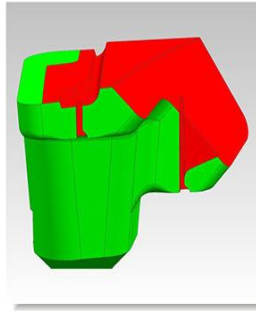
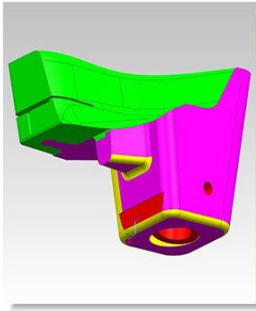

» Insert/Pin/Sprue

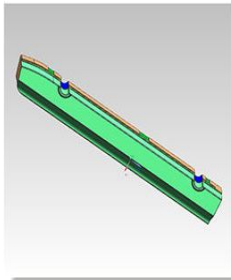
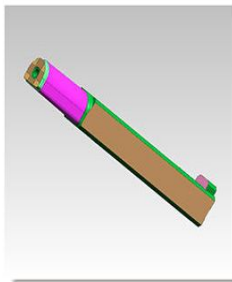
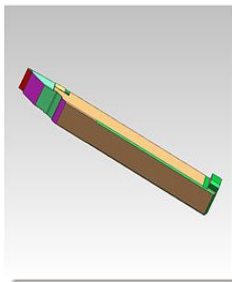
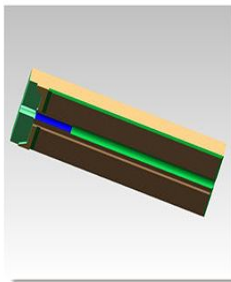
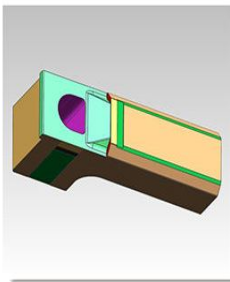
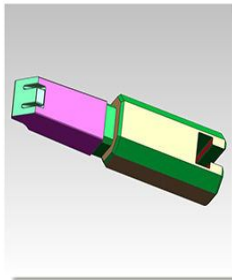
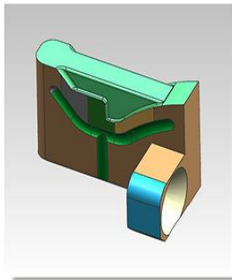
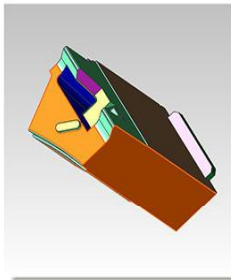
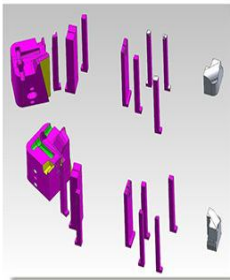
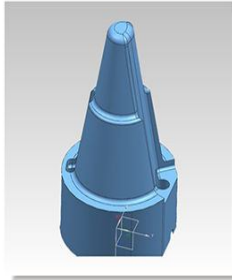
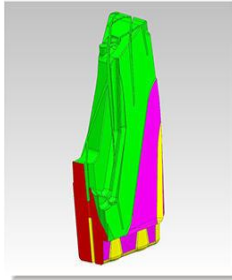
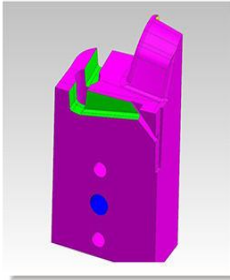

» Slide

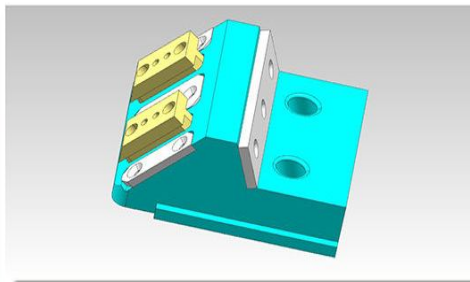
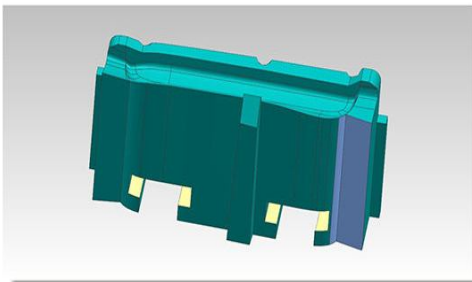
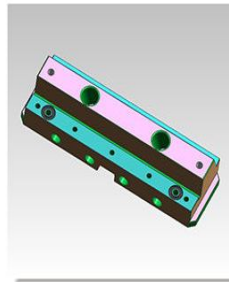
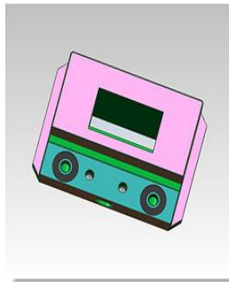
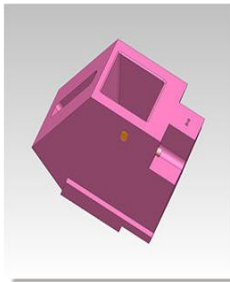
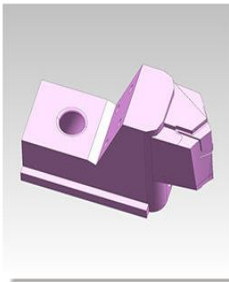
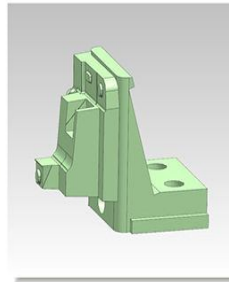
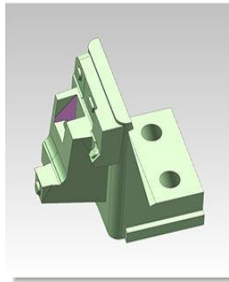
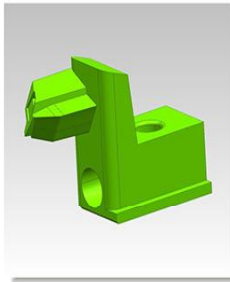
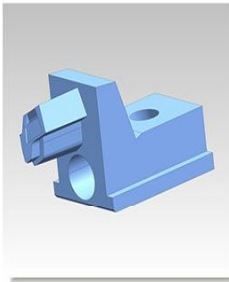
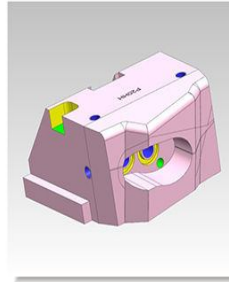
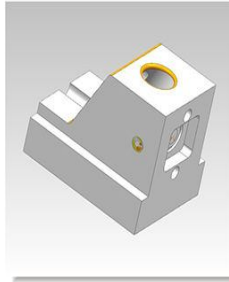
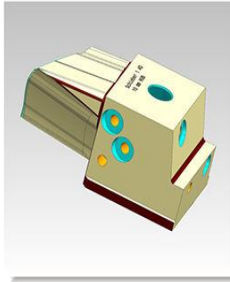
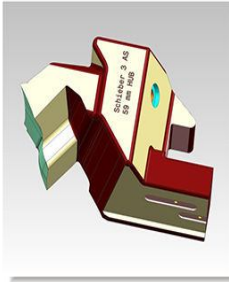

» Wear plate/locking heel

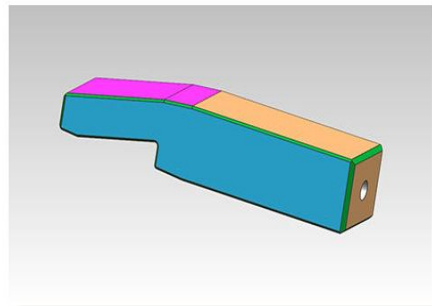
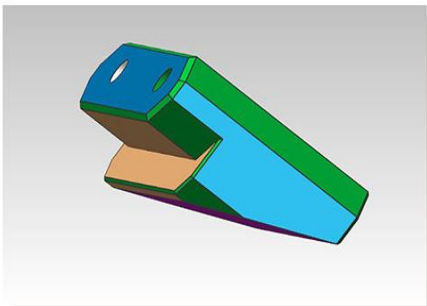
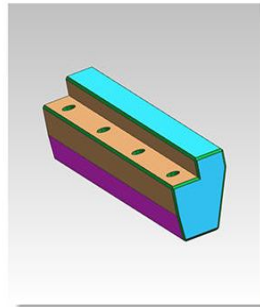
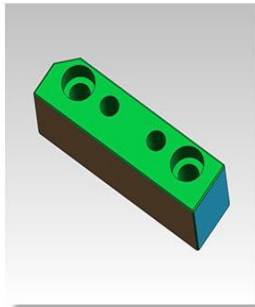
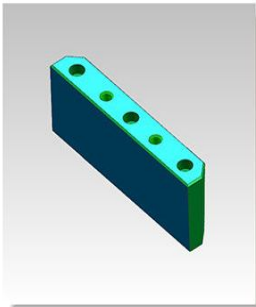
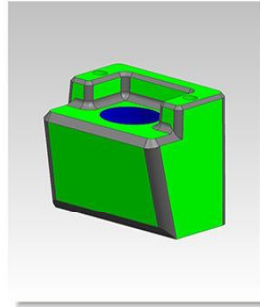
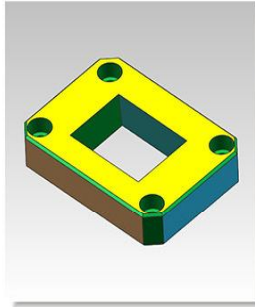
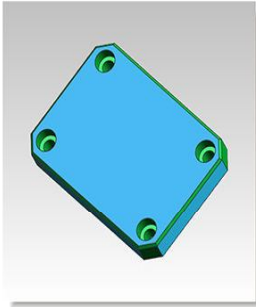
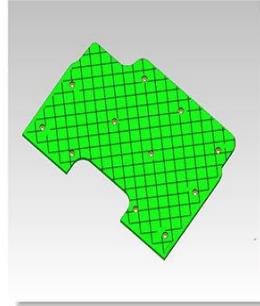
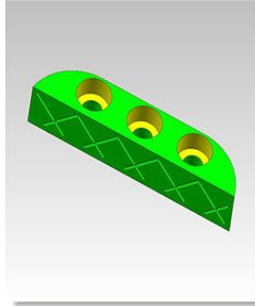
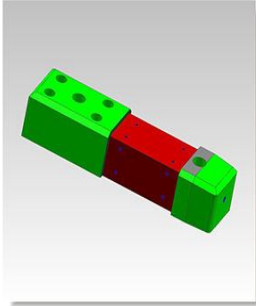



» Detecting device



» Machining equipment

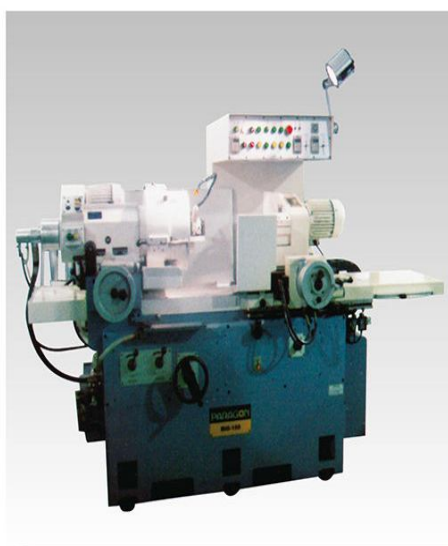

» Machining equipment

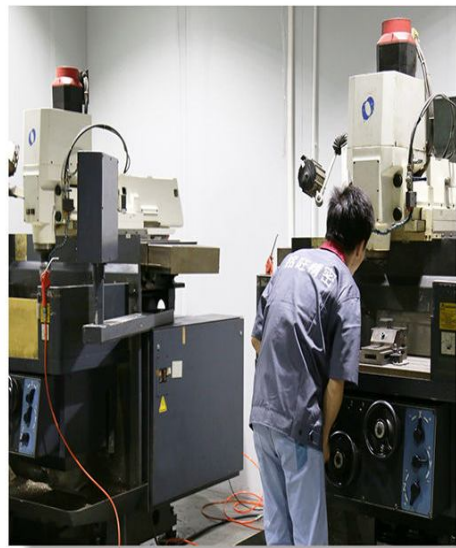
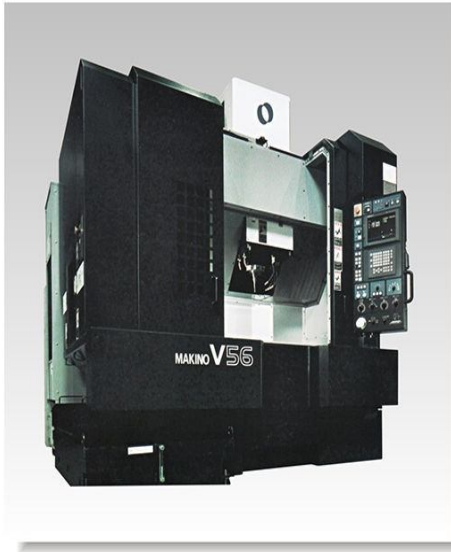



Micheal Wong

黄满球

Sales manager  
Foreign trade Department  
Dongguan, China

Mobile: +86 13412760980  
Tel: +86-769-83552817  
Fax: +86-769-83825686

Email: [w.micheal@upsmould.net](mailto:w.micheal@upsmould.net) skype:  
Website: [www.upsmould.net](http://www.upsmould.net)

Add: NO.9 Industrial Avenue, Luwu village, ChangpingTown,  
DongguanCity 523587, Guangdong Province, P.R. China

**UPS MOLD CO., LIMITED.**  
**东莞市路旺模具有限公司**



**UPS MOLD CO., LIMITED.**

1. Automotive plastic injection mold  
(Auto light-Auto rear-view mirror-Auto  
center stack and so on)
2. Agent of all brand-name mold base