



AL AHPT_{EC}

• MILLING CATALOG

RI HSIUNG
PRECISION
TECH



Index For Cutter 產品目錄/分類索引

High Speed Drill 快速鑽頭

DRS	10-15
DRW	16-21

Square Shoulder Milling Cutter 方肩銑刀桿/盤

AXO	22-24
DS390	25-27
AXN	28
SRT	29-30
NSAX	31-33
MAO12	34-35
MAP	36-39
GLM	40
HHU	41
HEX	42-43
NSEM	44
GTP	45-47

45°Face Milling Cutter 45度平面銑刀桿/盤

ASE	48
WC403	49
MSSE13	50
GSET12	51-52
GSEN12	53-54
GSEN15	54
AFC	55

65°/75°Face Cutter 65/75度平面銑刀盤

GSPK	56
GSPU12	57

Octagon Face Cutter 八角平面銑刀盤

OFC05	58
-------	-------	----

High-Feed Milling Cutter 高速進給銑刀桿/盤

AHF	59-60
JHF	61-62
HRF12	63-64
HSR	65-67
ESR	68

Helical Milling Cutter 螺旋銑刀/盤

AXO	69-70
WHGH	71-72
BT50	73

Drilling & Milling Cutter 鑽銑刀桿

HJ2	74
HJU	75

 45° Chamfering Milling Cutter
45度倒角刀桿

CM	76
CMT	77

 T-Slot Milling Cutter
T型槽銑刀桿

RTS	78
-----	-------	----

 Disc Milling Cutter
圓銑刀刀盤

DSC	79-80
-----	-------	-------

 Bolt Countersink Milling Cutter
沉頭孔銑刀桿

SCM	81
-----	-------	----

 Twin-Blade Boring Bar Cutter
固定式雙刃粗精刀桿

RTB	82
-----	-------	----

 Copy Milling Cutter
仿形銑刀桿/盤

ARD	83/85/86
ART	84/86
ARP	85
WC234	87
NSP	88
BT40-NSP	89
SRD	90-91
MRP	92
HRS	93-94
KBZC	95/97
KB218	96
W2139	98
WHBW	100
HBP	102
AXP	103-104

 Plunge Milling Cutter
插銑刀

AAP	99/101
-----	-------	--------

 Modular Cylinder Holder
鎖牙式刀柄

MCH	105
-----	-------	-----

 Modular Anti-Vibration Carbide Holder
鎖牙式鎢鋼抗震刀柄

MCHD	106
------	-------	-----

 Modular BT Shank Holder
鎖牙式刀柄

BT30/BT40/BT50	107
----------------	-------	-----

 Shell Mill Holder
面銑刀柄

E3414	108
E3416	109
E3469	110
E3471	111
E9304	112
E9306	113

INSERT

INSERT

Index For Insert 廠牌推薦/分類索引

SC series

DRS	10-15
DRW	16-21
AXO	22-24
AXN	28
ASE	48
AFC	55
OFC05	58
AHF	59-60
DSC	79-80
ARD	83/85/86
ART	84/86
ARP	85
KB218	96
W2139	98
AXP	103-104
AAP	99/101

MB series

MAO12	34-35
MAP	36-39
MSSE13	50
JHF	61-62
ART	84/86
ARD	83/85/86
ARP	85
MRP	92

SF series

SRT	29-30
SRD	90-91

ST series

NSAX	31-33
NSEM	50
NSP	88
BT40-NSP	89

SV series

DS390	25-27
MSSE13	50

WT series

WC403	49
OFC05	58
WHGH	71-72
BT50	73
WC234	87
KBZC	95/97
W2139	98
WHBN	100

NC series

NSAX	31-33
NSEM	44
NSP	88
BT40-NSP	89

HT series

HHU	41
HEX	42-43
HRF12	63-64
HSR	65-67
ESR	68
WHGH	71-72
BT50	73
HJ2	74
HJU	75
HRS	93-94
HBP	102

LM series

GLM	40
-----	-------	----

ISO series

GLM	40
GTP	45-47
GSET12	51-52
GSEN12	53-54
GSEN15	54
AFC	55
GSPK	56
GSPU12	57
WHGH	71-72
HJU	75
CM	76
CMT	77
RTS	78
SCM	81
RTB	82

AL AHPT_{INC}

• MILLING CATALOG

RI HSIUNG
PRECISION
TECH

ICON

Index For Icon Description 圖示說明/分類索引

刀桿材質 CUTTER MATERIAL

- SAE** SAE4340 鎳鉻鉻合金鋼
- SKD** SKD61 熱作合金工具鋼
- ALU** ALU ALLOY 鋁合金

刀桿表面處理 SURFACE HEAT TREATMENT

- OX** ANODIZING 氧化防鏽處理
- NI** ELECTROLESS NICKEL PLANTING 無電解鍍鎳處理

使用刀片 RECOMMAND FOR INSERT

- SC** SECO
- SV** Sandvik
- NC** Nachi
- ISO** ISO code
- SF** Safety
- MB** Mitsubishi
- LM** Lamina
- ST** Sumitomo
- WT** Walter
- HT** Hitachi

中心水孔 COOLANT HOLE

C.HOLE

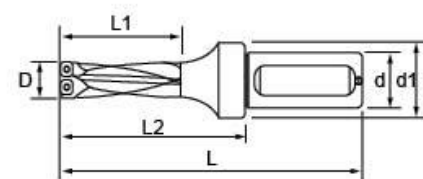
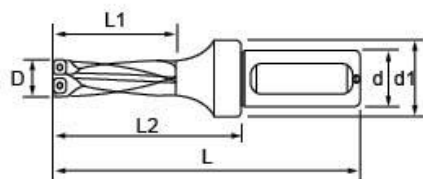
3D High Speed Drill
3D 快速鑽頭3D High Speed Drill
3D 快速鑽頭

ITEM 產品代號

ITEM 產品代號	SPECIFICATION 規格 (mm)			INSERT 刀片型號	SCREW 刀片螺絲	WHLANCH 柄子
	D	d	d1			
DRS3-12.539-d20	12.5					
DRS3-1339-d20	13					
DRS3-13.542-d20	13.5	20	25	SPMG050204	SC-2003	
DRS3-1442-d20	14					
DRS3-14.542-d20	14.5					
DRS3-1545-d20	15					
DRS3-15.548-d25	15.5					TG
DRS3-1648-d25	16					
DRS3-16.551-d25	16.5					
DRS3-1751-d25	17					
DRS3-17.554-d25	17.5					TG
DRS3-1854-d25	18					
DRS3-18.557-d25	18.5					
DRS3-1957-d25	19	25	33	SPMG060204	SC-2202	
DRS3-19.560-d25	19.5					
DRS3-2060-d25	20					
DRS3-20.563-d25	20.5					
DRS3-2163-d25	21					TG
DRS3-21.566-d25	21.5					
DRS3-2266-d25	22					
DRS3-22.569-d32	22.5					
DRS3-2369-d32	23					TG
DRS3-23.572-d32	23.5					
DRS3-2472-d32	24					
DRS3-24.575-d32	24.5	32	43	SPMG07T308	SC-2511	
DRS3-2575-d32	25					
DRS3-25.578-d32	25.5					
DRS3-2678-d32	26					

ITEM 產品代號

ITEM 產品代號	SPECIFICATION 規格 (mm)			INSERT 刀片型號	SCREW 刀片螺絲	WHLANCH 柄子
	D	d	d1			
DRS3-26.581-d32	26.5					SPMG07T308
DRS3-2781-d32	27					
DRS3-27.584-d32	27.5					
DRS3-2884-d32	28					
DRS3-28.587-d32	28.5					SPMG090408
DRS3-2987-d32	29					
DRS3-29.590-d32	29.5					
DRS3-3090-d32	30					
DRS3-30.593-d32	30.5					SPMG090408
DRS3-3193-d32	31	32	43			
DRS3-31.596-d32	31.5					
DRS3-3296-d32	32					
DRS3-32.599-d32	32.5					TG
DRS3-3399-d32	33					
DRS3-34102-d32	34					
DRS3-35105-d32	35					
DRS3-36108-d32	36					SPMG110408
DRS3-37111-d32	37					
DRS3-38114-d32	38					
DRS3-39117-d32	39					
DRS3-41120-d40	40					TG
DRS3-41123-d40	41					
DRS3-42126-d40	42					
DRS3-43129-d40	43					
DRS3-44132-d40	44					SPMG110408
DRS3-45135-d40	45					
DRS3-46138-d40	46					
DRS3-47141-d40	47					
DRS3-48144-d40	48					SPMG140512
DRS3-49147-d40	49					
DRS3-50150-d40	50					



2D High Speed Drill
2D 快速鑽頭

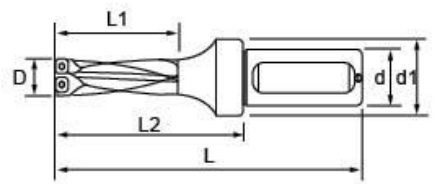

2D High Speed Drill
2D 快速鑽頭

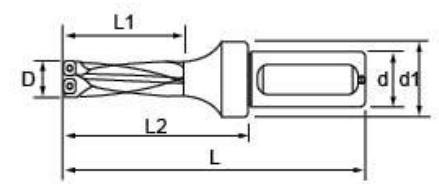

ITEM 產品代號	SPECIFICATION 規格 (mm)			INSERT 刀片型號	SCREW 刀片螺絲	W/DRILL 柄子	
	D	d	d1				L
DRW2-142B-d25	14				SC-2502		
DRW2-14.52B-d25	14.5						
DRW2-1530-d25	15			110	30	60	
DRW2-15.530-d25	15.5						
DRW2-1632-d25	16			110	32	63	
DRW2-16.532-d25	16.5						
DRW2-1734-d25	17			120	34	64	
DRW2-17.534-d25	17.5	25	38				
DRW2-1836-d25	18			122	36	66	
DRW2-18.536-d25	18.5						
DRW2-1938-d25	19			124	38	68	
DRW2-19.538-d25	19.5						
DRW2-2040-d25	20			126	40	70	
DRW2-20.540-d25	20.5						
DRW2-2142-d25	21			128	42	72	
DRW2-21.542-d25	21.5						
DRW2-2244-d32	22			136	44	76	
DRW2-22.544-d32	22.5						
DRW2-2346-d32	23			138	46	78	
DRW2-23.546-d32	23.5						
DRW2-2448-32d	24			141	48	81	
DRW2-24.548-32d	24.5						
DRW2-2550-32d	25	32	43	142	50	82	
DRW2-25.550-32d	25.5						
DRW2-2652-32d	26			144	52	84	
DRW2-2754-32d	27			146	54	86	
DRW2-2856-32d	28			148	56	88	
DRW2-2958-32d	29			150	58	90	
DRW2-3060-32d	30			152	60	92	

ITEM 產品代號	SPECIFICATION 規格 (mm)			INSERT 刀片型號	SCREW 刀片螺絲	ATTACH 柄子	
	D	d	d1				L
DRW2-3162-d32	31			154	62	94	
DRW2-3264-d32	32			156	64	96	
DRW2-3366-d32	33			159	66	99	
DRW2-3468-d32	34			160	68	100	
DRW2-3570-d32	35	32	43	162	70	102	
DRW2-3672-d32	36			164	72	104	
DRW2-3774-d32	37			166	74	106	
DRW2-3876-d32	38			168	76	106	
DRW2-3978-d32	39			170	78	110	
DRW2-4080-d40	40			185	80	115	
DRW2-4182-d40	41			187	82	117	
DRW2-4284-d40	42			189	84	119	
DRW2-4386-d40	43			191	86	121	
DRW2-4488-d40	44			194	88	124	
DRW2-4590-d40	45			195	90	125	
DRW2-4692-d40	46			197	92	127	
DRW2-4794-d40	47		54	199	94	129	
DRW2-4896-d40	48			201	96	131	
DRW2-4998-d40	49			202	98	132	
DRW2-50100-d40	50	40		204	100	134	
DRW2-51102-d40	51			206	102	136	
DRW2-52104-d40	52			208	104	138	
DRW2-53106-d40	53			210	106	140	
DRW2-54108-d40	54			212	108	142	
DRW2-55110-d40	55			215	110	145	
DRW2-56112-d40	56		58	217	112	147	
DRW2-57114-d40	57			219	114	149	
DRW2-58116-d40	58			221	116	151	
DRW2-59118-d40	59		59	223	118	153	
DRW2-60120-d40	60		63	225	120	155	

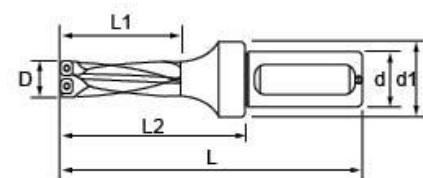
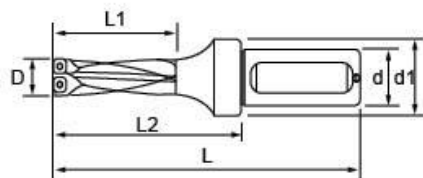
3D High Speed Drill
3D 快速鑽頭

18/19

ITEM 產品代號	SPECIFICATION 規格 (mm)			INSERT 刀片型號	SCREW 刀片螺絲	W/BLANCH 銑子
	D	d	d1			
DRW3-1442-d25	14			WCMX030208	SC-2502	
DRW3-14.542-d25	14.5					
DRW3-1545-d25	15					
DRW3-15.545-d25	15.5					
DRW3-1648-d25	16					
DRW3-16.548-d25	16.5					
DRW3-1751-d25	17					
DRW3-17.551-d25	17.5					
DRW3-1854-d25	18					
DRW3-18.554-d25	18.5					
DRW3-1957-d25	19			SC-2507	T8	
DRW3-19.557-d25	19.5					
DRW3-2060-d25	20					
DRW3-20.560-d25	20.5					
DRW3-2163-d25	21					
DRW3-21.564-d25	21.5					
DRW3-2266-d32	22					
DRW3-22.566-d32	22.5					
DRW3-2369-d32	23					
DRW3-23.569-d32	23.5					
DRW3-2472-32d	24			WCMX040208		
DRW3-24.572-32d	24.5					
DRW3-2575-32d	25					
DRW3-25.575-32d	25.5					
DRW3-2678-32d	26					
DRW3-2781-32d	27					
DRW3-2884-32d	28					
DRW3-2987-32d	29					
DRW3-3090-32d	30					
DRW3-30.93-32d	30.5					
DRW3-3193-32d	31			WCMX050308	SC-3007	T10
				WCMX06T308	SC-3502	T15

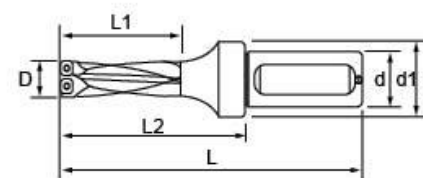
3D High Speed Drill
3D 快速鑽頭

ITEM 產品代號	SPECIFICATION 規格 (mm)			INSERT 刀片型號	SCREW 刀片螺絲	W/BLANCH 銑子
	D	d	d1			
DRW3-31.593-d32	31.5			WCMT06T308	SC-3502	
DRW3-3296-d32	32					
DRW3-32.596-d32	32.5					
DRW3-3399-d32	33					
DRW3-34102-d32	34	32	43			
DRW3-35105-d32	35					
DRW3-36108-d32	36					
DRW3-37111-d32	37					
DRW3-38114-d32	38					
DRW3-39117-d32	39					
DRW3-40120-d40	40			WCMT080412	SC-4004	T15
DRW3-41123-d40	41					
DRW3-42126-d40	42					
DRW3-43129-d40	43					
DRW3-44132-d40	44					
DRW3-45135-d40	45					
DRW3-46138-d40	46	54				
DRW3-47141-d40	47					
DRW3-48144-d40	48					
DRW3-49147-d40	49	40				
DRW3-50150-d40	50					
DRW3-51153-d40	51					
DRW3-52156-d40	52					
DRW3-53159-d40	53					
DRW3-54162-d40	54					
DRW3-55165-d40	55					
DRW3-56168-d40	56	58				
DRW3-57171-d40	57					
DRW3-58174-d40	58	50				
DRW3-59177-d40	59					
DRW3-60180-d40	60	63				

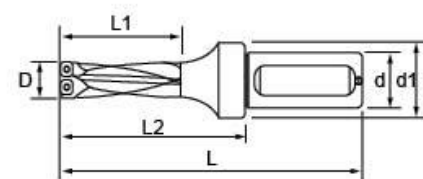
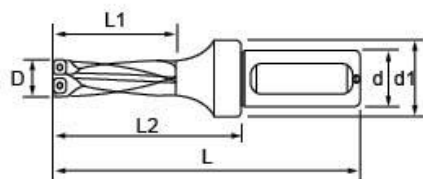
4D High Speed Drill
4D 快速鑽頭

ITEM 產品代號

ITEM 產品代號	SPECIFICATION 規格 /mm			L	L1	L2	INSERT 刀片型號	SCREW 刀片螺絲	WRENCH 扳手
	D	d	d1						
DRW4-145G-d25	14			142	56	86	WCMX030208	SC-2502	T8
DRW4-150G-d25	15			146	60	90			
DRW4-1664-d25	16			150	64	94			
DRW4-1768-d25	17	25	38	154	68	98			
DRW4-1872-d25	18			158	72	102			
DRW4-1976-d25	19			162	76	106			
DRW4-2080-d25	20			166	80	110			
DRW4-2184-d25	21			170	84	114			
DRW4-2288-d32	22			180	88	120			
DRW4-2392-d32	23			184	92	124			
DRW4-2496-32d	24			188	96	128			
DRW4-25100-32d	25			192	100	132			
DRW4-26104-32d	26			196	104	136			
DRW4-27108-32d	27			200	108	140			
DRW4-28112-32d	28			204	112	144			
DRW4-29116-32d	29			208	116	148			
DRW4-30120-32d	30	32	43	212	120	152			
DRW4-31124-32d	31			216	124	156			
DRW4-32128-32d	32			220	128	160			
DRW4-33132-32d	33			224	132	164			
DRW4-34136-32d	34			228	136	168			
DRW4-35140-32d	35			232	140	172			
DRW4-36144-32d	36			236	144	176			
DRW4-37148-32d	37			240	148	180			

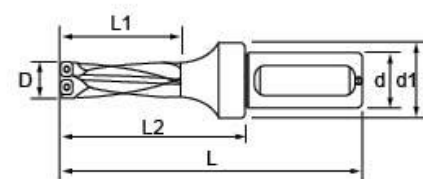
4D High Speed Drill
4D 快速鑽頭

ITEM 產品代號

ITEM 產品代號	SPECIFICATION 規格 /mm			L	L1	L2	INSERT 刀片型號	SCREW 刀片螺絲	WRENCH 扳手
	D	d	d1						
DRW4-38152-d32	38			244	152	184	WCMX06T308	SC-3502	T15
DRW4-39156-d32	39	32	43	248	156	188			
DRW4-40160-d40	40			265	160	195			
DRW4-41164-d40	41			269	164	199			
DRW4-42168-d40	42			273	168	203			
DRW4-43172-d40	43			277	172	207			
DRW4-44176-d40	44			282	176	212			
DRW4-45180-d40	45			285	180	215			
DRW4-46184-d40	46			289	184	219			
DRW4-47188-d40	47			293	188	223			
DRW4-48192-d40	48	40	54	297	192	227			
DRW4-49196-d40	49			301	196	231			
DRW4-50200-d40	50			305	200	235			
DRW4-51204-d40	51			309	204	239			
DRW4-52208-d40	52			313	208	243			
DRW4-53212-d40	53			317	212	247			
DRW4-54216-d40	54			321	216	250			
DRW4-55220-d40	55			325	220	255			
DRW4-56224-d40	56			329	224	259			
DRW4-57228-d40	57		58	333	228	263			
DRW4-58232-d40	58			337	232	267			
DRW4-59236-d40	59		59	341	236	271			
DRW4-60240-d40	60		63	345	240	275			



Square Shoulder Milling Cutter
方肩銑刀桿

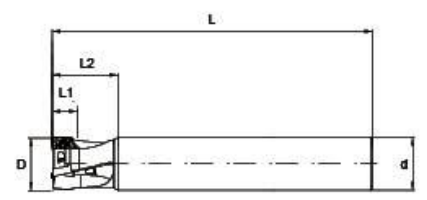

ITEM	產品代號	SPECIFICATION 規格 (mm)				TEST# 刃數	INSERT 刀片型號	SCREW 刀片螺絲	WHICH 銑字	
		D	d	L1	L2					L
AXO-1010-120KS-0G2		10	10		20	120	2			
AXO-1110-120KS-0G2		11	10		20	120	2			
AXO-1212-120KS-0G2		12	12		17	120	2			
AXO-1212-120KS-0G3		12	12	5	20	120	3	XO.0G02	SCR-XO1.8	T6
AXO-1312-120KS-0G2		13	12		33	120	2			
AXO-1412-150KS-0G3		14	12		25	150	3			
AXO-1616-150KS-0G3		16	16		25	150	3			
AXO-1616-150KS-0G2		16	16		25	150	2			
AXO-1716-150KS-0G2		17	16		25	150	2			
AXO-1816-150KS-0G2		18	16	8	25	150	2	XO.0903	SCR-XO2.5	T8
AXO-2020-150KS-0G3		20	20		20	150	3			
AXO-2020-200KS-0G3		20	20		20	200	3			
AXO-2525-200KS-0G4		25	25		30	200	4			
AXO-2020-05KS-122		20	20		26	95	2			
AXO-2020-150KS-122		20	20		26	150	2			
AXO-2020-200KS-122		20	20		26	200	2			
AXO-2120-150KS-122		21	20		26	150	2			
AXO-2220-150KS-122		22	20		26	150	2			
AXO-2525-95KS-123		25	25	11	32	95	3	XO.1204	SCR-XO3.5	T10
AXO-2525-150KS-123		25	25		32	150	3			
AXO-2525-200KS-123		25	25		32	200	3			
AXO-2625-150KS-123		26	25		32	150	3			
AXO-3232-150KS-123		32	32		32	150	3			
AXO-3232-200KS-123		32	32		32	200	3			
AXO-4040-150KS-124		40	40		32	150	4			



Square Shoulder Milling Modular Cutter
鎖牙式方肩銑刀頭

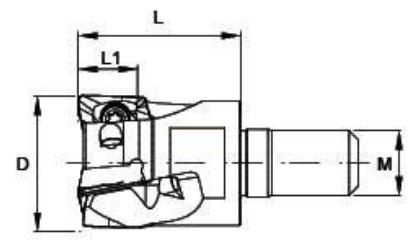

ITEM	產品代號	SPECIFICATION 規格 (mm)				TEST# 刃數	INSERT 刀片型號	SCREW 刀片螺絲	WHICH 銑字
		D	M	L1	L				
AXO-0510-0G.2A		10	M5		18	2			
AXO-0511-0G.2A		11	M5	5	18	2	XO.0G02	SCR-XO1.8	T6
AXO-0612-0G.3A		12	M6		19	3			
AXO-0613-0G.3A		13	M6		19	3			
AXO-0816-0G.2A		16	M8		25	2			
AXO-0817-0G.2A		17	M8		25	2			
AXO-1020-0G.3A		20	M10	8	30	3	XO.0903	SCR-XO2.5	T8
AXO-1021-0G.3A		21	M10		30	3			
AXO-1025-0G.4A		25	M10		30	4			
AXO-1020-12.2A		20	M10		30	2			
AXO-1021-12.2A		21	M10		30	2			
AXO-1220-12.2		20	M12		30	2			
AXO-1220S32-12.2		20	M12		35	2			
AXO-1221-12.2A		21	M12		35	2			
AXO-1225-12.3A		25	M12	11	43	3	XO.1204	SCR-XO3.5	T10
AXO-1226-12.3A		26	M12		43	3			
AXO-1632-12.4A		32	M16		43	4			
AXO-1635-12.4A		35	M16		32	4			
AXO-1640-12.5A		40	M16		32	5			



Square Shoulder Milling Cutter
方肩銑刀盤

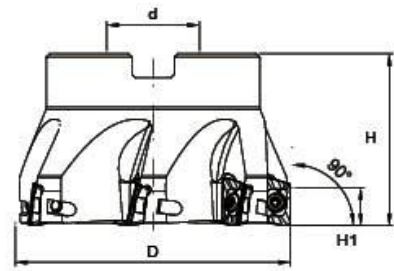

ITEM	產品代號	SPECIFICATION 規格 (mm)				TEETH 刃數	INSERT 刀片型號	SCREW 刀片螺絲	W/RECH 扳手
		D	d	H1	H				
AXO-FM50.22-125A		50	22		40	5	XO.1204	SCR-X03.5	T10
AXO-FMG3.27-126A		G3	27		40	6			
AXO-FM80.27-127A		80	27	11	50	7			
AXO-FM100.32-128A		100	32		50	8			



Square Shoulder Milling Cutter
方肩銑刀桿

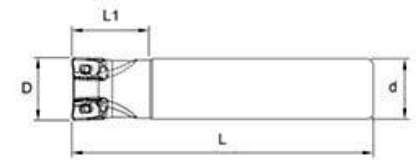

ITEM	產品代號	SPECIFICATION 規格 (mm)				TEETH 刃數	INSERT 刀片型號	SCREW 刀片螺絲	W/RECH 扳手
		D	d	L1	L				
DS390-121G-100-111		12	16	25	100	1	R390-11T3	SCR-2507	T8
DS390-161G-150-112		16	16	30	150	2			
DS390-171G-150-112		17	16	30	150	2			
DS390-181G-150-112		18	16	30	150	2			
DS390-202G-150-112		20	20	30	150	2			
DS390-202G-150-113		20	20	30	150	3			
DS390-212G-150-112		21	20	30	150	2			
DS390-222G-150-113		22	20	30	150	3			
DS390-252G-150-112		25	25	30	150	2			
DS390-252G-150-113		25	25	30	150	3			
DS390-302G-150-113		30	25	30	150	3			
DS390-323G-150-113		32	32	35	150	3			
DS390-323G-150-115		32	32	35	150	5			
DS390-333G-150-113		33	32	35	150	3			
DS390-333G-150-115		33	32	35	150	5			
DS390-353G-150-113		35	32	35	150	3			
DS390-353G-150-115		35	32	35	150	5			
DS390-403G-150-114		40	32	35	150	4			
DS390-403G-150-116		40	32	35	150	6			
DS390-252G-150-172		25	25	40	150	2			
DS390-262G-150-172		26	25	40	150	2			
DS390-282G-150-172		28	25	40	150	2			
DS390-302G-150-172		30	25	40	150	2			
DS390-323G-150-172		32	32	45	150	2			
DS390-323G-150-173		32	32	45	150	3			
DS390-333G-150-172		33	32	45	150	2			
DS390-333G-150-173		33	32	45	150	3			
DS390-353G-150-173		35	32	45	150	3			
DS390-403G-150-174		40	32	45	150	4			
							R390-1704	SCR-4005	T15



Square Should Milling Modular Cutter
鎖牙式方肩銑刀頭

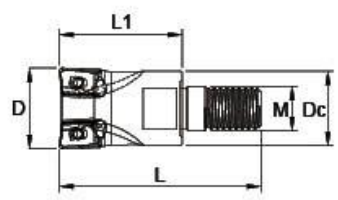

ITEM	產品代號	SPECIFICATION				TEETH 刃數	INSERT 刀片型號	SCREW 刀片螺絲	WRENCH 扳手	
		D	M	Do	L1					L
DS390-0612-11.1		12	MG	11	24	40	R390-11T3	SCR-2503-8	T8	
DS390-0816-11.2		16	M8	15	26	43				2
DS390-0817-11.2		17	M8	15	26	43				2
DS390-0818-11.2		18	M8	15	32	43				2
DS390-1020-11.2		20	M10	18	32	50				2
DS390-1020-11.3		20	M10	18	32	50				3
DS390-1021-11.2		21	M10	18	32	50				2
DS390-1022-11.3		22	M10	18	32	50				3
DS390-1225-11.2		25	M12	23	38	60				2
DS390-1225-11.3		25	M12	23	38	60				3
DS390-1230-11.3		30	M12	23	41	60				3
DS390-1632-11.3		32	M16	29	41	63				3
DS390-1632-11.5		32	M16	29	41	63				5
DS390-1633-11.3		33	M16	29	41	63				3
DS390-1633-11.5		33	M16	29	41	63				5
DS390-1635-11.3		35	M16	32	41	63				3
DS390-1635-11.5		35	M16	32	41	63				5
DS390-1640-11.4		40	M16	32	43	65				4
DS390-1640-11.6		40	M16	32	43	65				6
DS390-1225-17.2		25	M12	23	38	60				2
DS390-1226-17.2		26	M12	23	38	60				2
DS390-1228-17.2		28	M12	25	38	60				2
DS390-1230-17.2		30	M12	25	38	60				2
DS390-1632-17.2		32	M16	29	41	63				2
DS390-1632-17.3		32	M16	29	41	63	3			
DS390-1633-17.2		33	M16	29	41	63	2			
DS390-1633-17.3		33	M16	29	41	63	3			
DS390-1635-17.3		35	M16	32	41	63	3			
DS390-1640-17.4		40	M16	32	43	65	4			
DS390-1640-17.4		40	M16	32	43	65	4			
DS390-1640-17.4		40	M16	32	43	65	4			



Square Shoulder Milling Cutter
方肩銑刀盤

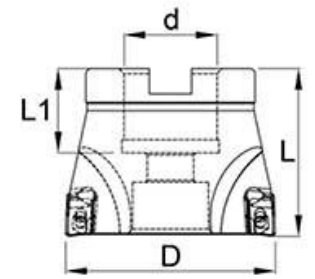

ITEM	產品代號	SPECIFICATION				TEETH 刃數	INSERT 刀片型號	SCREW 刀片螺絲	WRENCH 扳手
		D	d	L1	L				
DS390-FM50.22-114		50	22	21	40	4	R390-11T3	SCR-2503-8	T8
DS390-FM50.22-115		50	22	21	40	5			
DS390-FM63.22-115		63	22	21	40	5			
DS390-FM63.22-116		63	22	21	40	6			
DS390-FM80.27-116		80	27	23	50	6			
DS390-FM80.27-118		80	27	23	50	8			
DS390-FM100.32-117		100	32	23	50	7			
DS390-FM100.32-1110		100	32	23	50	10			
DS390-FM50.22-174		50	22	21	40	4			
DS390-FM63.22-175		63	22	21	40	5			
DS390-FM80.27-176		80	27	23	50	6			
DS390-FM100.32-177		100	32	23	50	7			
DS390-FM125.40-178		125	40	32	63	8			
DS390-FM160.40-1710		160	40	32	63	10			
DS390-FM160.40-1710		160	40	32	63	10			
DS390-FM160.40-1710		160	40	32	63	10			



Square Shoulder Milling Cutter
方肩銑刀盤

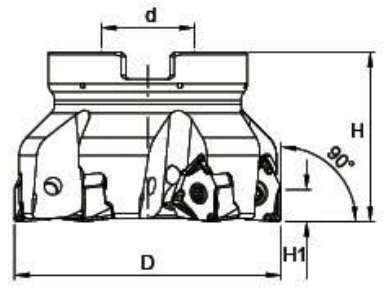

ITEM	產品代號	SPECIFICATION 規格 (mm)				TEETH 刃數	INSERT 刀片型號	SCREW 刀片螺絲	W/COAT 鍍層
		D	d	H1	H				
AXN-FM50.22-084A		50	22		40	4	XN..0806	SC4006	T15
AXN-FMG3.22-086A		G3	22		40	6			
AXN-FM80.27-087A		80	27	7.5	50	7			
AXN-FM100.32-088A		100	32		50	8			
AXN-FM125.40-0811A		125	40		63	11			



Square Shoulder Milling Cutter
方肩銑刀桿

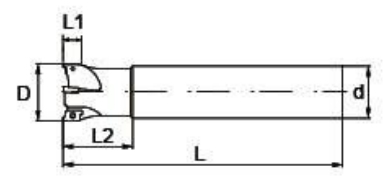

ITEM	產品代號	SPECIFICATION 規格 (mm)					TEETH 刃數	INSERT 刀片型號	SCREW 刀片螺絲	W/COAT 鍍層
		D	d	L1	L2	L				
SRT07-1002.10-130		10	10			130	2	RT0702	SCR-SRT2.0	T6
SRT07-1102.10-120		11	10			120	2			
SRT07-1202.12-130		12	12			130	2			
SRT07-1302.12-130		13	12	6	30	130	2			
SRT07-1603.16-150		16	16			150	3			
SRT07-1703.16-150		17	16			150	3			
SRT10-1602.16-150		16	16			150	2	RT1003	SCR-SRT2.5	T8
SRT10-1702.16-150		17	16			150	2			
SRT10-1702.16-200		17	16			200	2			
SRT10-2003.20-150		20	20			150	3			
SRT10-2103.20-150		21	20			150	3			
SRT10-2103.20-200		21	20			200	3			
SRT10-2103.20-250		21	20			250	3			
SRT10-2503.25-200		25	25	9	50	200	3			
SRT10-2603.25-150		26	25			150	3			
SRT10-2603.25-200		26	25			200	3			
SRT10-2603.25-250		26	25			250	3			
SRT10-2603.25-300		26	25			300	3			
SRT10-3504.32-150		35	32			150	4			
SRT10-3504.32-200		35	32			200	4			
SRT10-3504.32-250		35	32			250	4			
SRT10-3504.32-300		35	32			300	4			



Square Shoulder Milling Modular Cutter
鎖牙式方肩銑刀頭

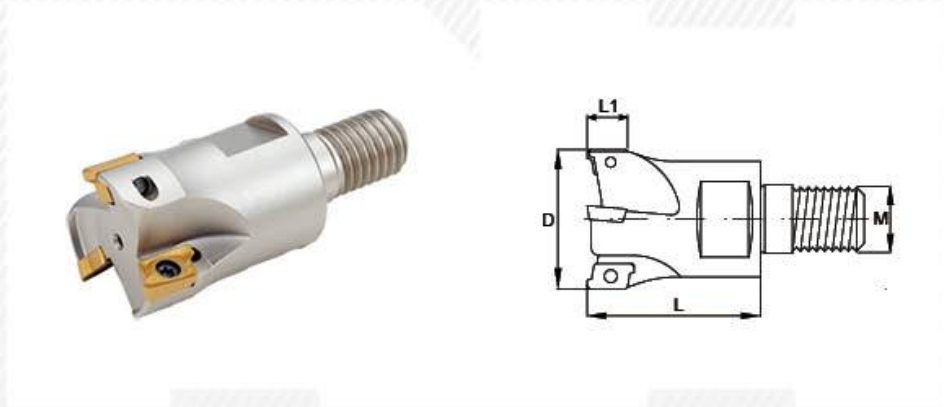

ITEM	產品代號	SPECIFICATION 規格				TEETH 刃數	INSERT 刀片型號	SCREW 刀片螺絲	WRENCH 扳手
		D	M	L1	L				
SRT07-1002M5		10	M5		18	2	RT0702	SCR-SRT2.0	TG
SRT07-1102M5		11	M5	6	18	2			
SRT07-1202M6		12	M6		19	2			
SRT07-1302M6		13	M6		19	2			
SRT07-1603M8		16	M8		25	3			
SRT07-1703M8		17	M8		25	3			
SRT10-1602M8		16	M8			25	2	RT1003	SCR-SRT2.5
SRT10-1702M8		17	M8		25	2			
SRT10-2003M10		20	M10	9	30	3			
SRT10-2103M10		21	M10		30	3			
SRT10-2503M12		25	M12		35	3			
SRT10-2603M12		26	M12		35	3			
SRT10-3504M16		35	M16		43	4			



Square Shoulder Milling Cutter
方肩銑刀桿

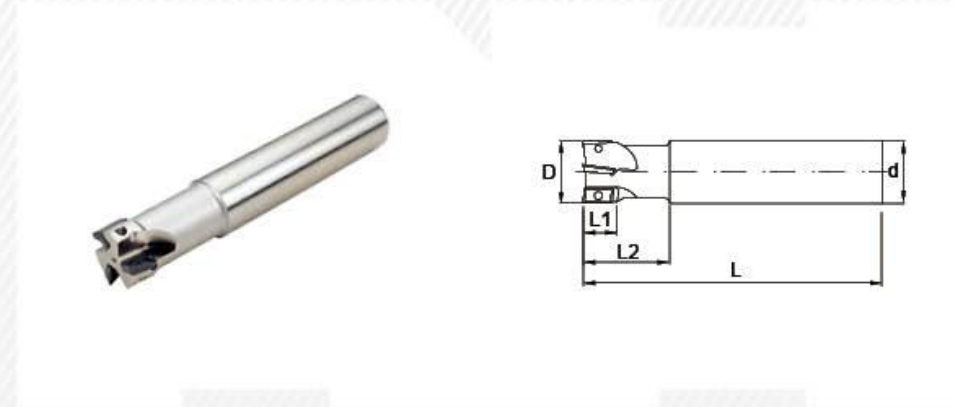

ITEM	產品代號	SPECIFICATION 規格			TEETH 刃數	INSERT 刀片型號	SCREW 刀片螺絲	WRENCH 扳手		
		D	d	L						
NSAX12-1616-120		16	16		35	120	2	AXMT1235	SCR-NSAX3	TB
NSAX12-1716-120		17	16		35	120	2			
NSAX12-1816-100		18	16		25	100	2			
NSAX12-1916-120		19	16		35	120	2			
NSAX12-2020-110		20	20		30	110	3			
NSAX12-2020-150		20	20		40	150	3			
NSAX12-2120-120		21	20		40	120	3			
NSAX12-2120-185		21	20		40	185	2			
NSAX12-2220-110		22	20		30	110	3			
NSAX12-2325-150		23	25	10	40	150	3			
NSAX12-2425-150		24	25		40	150	3			
NSAX12-2525-120		25	25		35	120	4			
NSAX12-2525-170		25	25		50	170	4			
NSAX12-2625-150		26	25		45	150	4			
NSAX12-2625-200		26	25		45	200	4			
NSAX12-2725-150		27	25		45	150	4			
NSAX12-2825-150		28	25		45	150	4			
NSAX12-2925-150		29	25		45	150	4			
NSAX12-3025-150		30	25		45	150	4			
NSAX12-3132-150		31	32		45	150	4			
NSAX12-3232-150		32	32		60	150	4			
NSAX12-3232-250		32	32		80	250	4			
NSAX12-3332-150		33	32		45	150	4			
NSAX12-3332-250		33	32		50	250	4			
NSAX12-3432-150		34	32		45	150	4			
NSAX12-3532-150		35	32		45	150	4			
NSAX12-3532-250		35	32		50	250	4			



Square Shoulder Milling Cutter
方肩銑刀桿

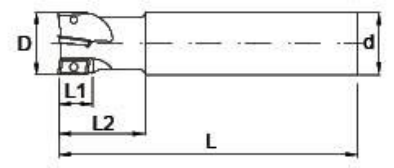

ITEM	產品代號	SPECIFICATION				TEETH 刃數	INSERT 刀片型號	SCREW 刀片螺絲	WALNUT 螺母
		Ø	d	L1	L2				
NSAX17-2525-120		25	25		35	120	2		
NSAX17-2525-200		25	25		40	200	2		
NSAX17-2625-120		26	25		35	120	2		
NSAX17-2625-200		26	25		45	200	2		
NSAX17-2725-150		27	25		40	150	2		
NSAX17-2725-200		27	25		45	200	2		
NSAX17-2825-120		28	25		35	120	2		
NSAX17-2825-200		28	25		45	200	2		
NSAX17-2925-150		29	25		40	150	2		
NSAX17-2925-200		29	25		45	200	2		
NSAX17-3025-150		30	25		40	150	2		
NSAX17-3025-200		30	25		45	200	2		
NSAX17-3125-150		31	25	15	40	150	2	AXMT1705	SCR-NSAX4
NSAX17-3132-250		31	32		70	250	2		
NSAX17-3232-130		32	32		40	130	3		
NSAX17-3232-250		32	32		70	250	2		
NSAX17-3332-150		33	32		45	150	3		
NSAX17-3332-250		33	32		50	250	2		
NSAX17-3432-150		34	32		45	150	3		
NSAX17-3432-250		34	32		50	250	2		
NSAX17-3532-150		35	32		45	150	3		
NSAX17-3532-250		35	32		50	250	2		
NSAX17-3632-150		36	32		45	150	3		
NSAX17-3632-250		36	32		50	250	2		
NSAX17-4032-150		40	32		50	150	4		
NSAX17-4032-250		40	32		50	250	4		



Square Shoulder Milling Cutter
方肩銑刀盤

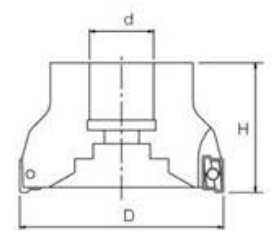

ITEM	產品代號	SPECIFICATION				TEETH 刃數	INSERT 刀片型號	SCREW 刀片螺絲	WALNUT 螺母
		Ø	d	d*	H				
NSAX12-FM50-2207		50	-			7			
NSAX12-FM63-2208		63	25.4	22		8	AXMT1235	SCR-NSAX3	T8
NSAX17-FM50-2205		50	-		40	7			
			-			5			
NSAX17-FM63-2206		63	25.4	27		6	AXMT1705	SCR-NSAX4	T15
NSAX17-FM80-2707		80	25.4	32	50	7			
NSAX17-FM100-3208		100	31.75	40	63	8			
NSAX17-FM125-4009		125	38.1		63	9			

● 訂購時請註明內孔 (d) 尺寸
Please note the diameter of "d" when you order.



Square Shoulder Milling Cutter
方肩銑刀桿

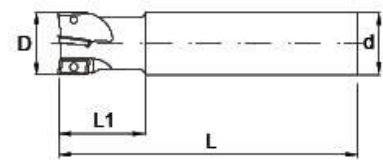

ITEM	產品代號	SPECIFICATION 規格 (mm)				TEETH 刃數	INSERT 刀片型號	SCREW 刀片螺絲	WRENCH 扳手
		D	d	L1	L				
MA012-121G-05		12	1G	25	05	1	AOMT123G	SCR-MA02.5	T8
MA012-141G-05		14	1G	25	05	1			
MA012-161G-150		16	1G	24	150	2			
MA012-171G-150		17	1G	24	150	2			
MA012-181G-150		18	1G	24	150	2			
MA012-2020-150		20	20	29	150	3			
MA012-2120-150		21	20	29	150	3			
MA012-2120-200		21	20	29	200	3			
MA012-2525-150		25	25	34	150	4			
MA012-2525-200		25	25	34	200	4			
MA012-2625-200		26	25	34	200	4			
MA012-2025-170		20	25	35	170	3			
MA012-3025-125		30	25	45	125	4			
MA012-3232-125		32	32	45	125	4			
MA012-3232-190		32	32	45	190	3			
MA012-3532-125		35	32	45	125	4			
MA012-3532-190		35	32	45	190	3			
MA012-4032-125		40	32	45	125	5			
MA012-4032-200		40	32	45	200	4			



Square Shoulder Milling Modular Cutter
直角面銑刀盤

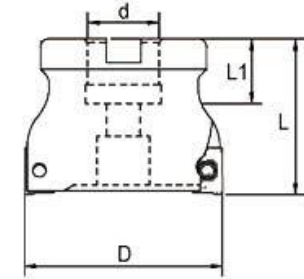

ITEM	產品代號	SPECIFICATION 規格 (mm)				TEETH 刃數	INSERT 刀片型號	SCREW 刀片螺絲	WRENCH 扳手
		D	d	L1	L				
MA012-FM50-2207		50	22	20	40	7	AOMT123G	SCR-MA02.5	T8
MA012-FMG3-2200		G3	22	20	40	8			
MA012-FM00-25.400		00	25.4	20	50	9			
MA012-FM100-31.7511		100	31.75	32	G3	11			



Square Shoulder Milling Cutter
方肩銼刀桿

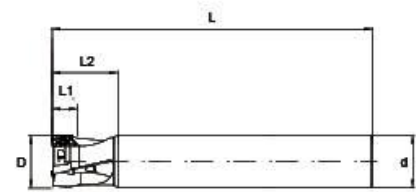

ITEM	產品代號	SPECIFICATION			TEETH	INSERT	SCREW	WRENCH
		D	d	L				
MAP30R-1010-100		10	10		1			
MAP30R-1016-100		10	16		1			
MAP30R-1212-100		12	12		1			
MAP30R-1216-100		12	16		1			
MAP30R-1312-100		13	12		1			
MAP30R-1412-100		14	12		1			
MAP30R-1616-120		16	16		2			
MAP30R-1616-160		16	16		2			
MAP30R-1716-100		17	16		2			
MAP30R-1816-100		18	16		2			
MAP30R-1916-100		19	16		2			
MAP30R-2020-120		20	20		2			
MAP30R-2020-150		20	20		2			
MAP30R-2020-200		20	20		2			
MAP30R-2120-100		21	20		3			
MAP30R-2220-100		22	20		3			
MAP30R-2320-100		23	20		3			
MAP30R-2420-100		24	20		3			
MAP30R-2525-150		25	25		4			
MAP30R-2525-200		25	25		4			
MAP30R-2525-250		25	25		4			
MAP30R-2625-120		26	25		4			
MAP30R-2725-120		27	25		4			
MAP30R-2825-120		28	25		4			
MAP30R-2925-120		29	25		4			
MAP30R-3025-120		30	25		4			
MAP30R-3125-120		31	25		4			
MAP30R-3232-120		32	32		5			
MAP30R-3332-120		33	32		5			
MAP30R-3432-120		34	32		5			
MAP30R-3532-120		35	32		5			
MAP30R-4032-120		40	32		5			
MAP30R-5032-120		50	32		6			



Square Shoulder Milling Cutter
方肩銼刀桿

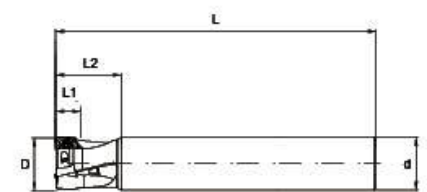

ITEM	產品代號	SPECIFICATION			TEETH	INSERT	SCREW	WRENCH
		D	d	L				
MAP40R-2525-150		25	25		2			
MAP40R-2525-200		25	25		2			
MAP40R-2525-250		25	25		2			
MAP40R-2625-150		26	25		2			
MAP40R-2625-200		26	25		2			
MAP40R-3025-250		30	25		2			
MAP40R-3232-150		32	32		3			
MAP40R-3232-200		32	32		3			
MAP40R-3232-250		32	32	14	3			
MAP40R-3232-300		32	32		3			
MAP40R-3532-150		35	32		3			
MAP40R-3532-200		35	32		3			
MAP40R-3532-250		35	32		3			
MAP40R-3532-300		35	32		3			
MAP40R-4032-150		40	32		3			
MAP40R-4032-200		40	32		3			
MAP40R-5032-150		50	32		4			
MAP40R-5032-200		50	32		4			
MAP40R-5042-150		50	42		4			

APMT1604 SCR-MAP4 T15



Square Shoulder Milling Modular Cutter
鎖牙式方肩銑刀頭

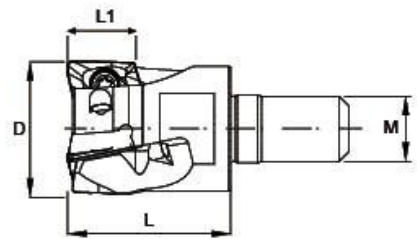

ITEM	產品代號	SPECIFICATION 規格 mm				TEETH 刃數	INSERT 刀片型號	SCREW 刀片螺絲	WHLNCH 銑手
		D	M	L1	L				
MAP30R-0816-11.2		16	M8		25	2	APMT 1135	SCR-MAP2.5	T8
MAP30R-0817-11.2		17	M8		25	2			
MAP30R-1020-11.2		20	M10	9	30	2			
MAP30R-1021-11.2		21	M10		30	2			
MAP40R-1225-16.2		25	M12		35	2	APMT 1604	SCR-MAP4	T15
MAP40R-1226-16.2		26	M12		35	2			
MAP40R-1632-16.3		32	M16		40	3			
MAP40R-1633-16.3		33	M16		40	3			



Square Shoulder Milling Cutter
方肩銑刀盤

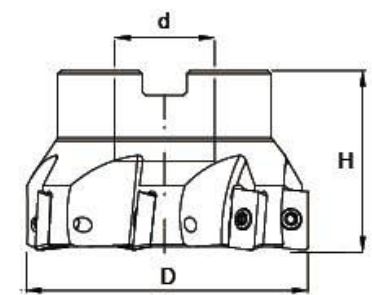

ITEM	產品代號	SPECIFICATION 規格 mm				TEETH 刃數	INSERT 刀片型號	SCREW 刀片螺絲	WHLNCH 銑手
		D	d	d ¹	H				
MAP30R-FM40-1605		40	-	16	40	5	APMT 1135	SCR-MAP2.5	T8
MAP30R-FM50-2206		50	25.4	22	45	6			
MAP30R-FM63-2207		63	25.4	22	45	7			
MAP30R-FM80-2708		80	25.4	27	50	8			
MAP30R-FM100-3210		100	31.75	32	50	10	APMT 1604	SCR-MAP4	T15
MAP40R-FM40-1604		40	-	16	40	4			
MAP40R-FM50-2205		50	25.4	22	45	5			
MAP40R-FM63-2206		63	25.4	22	45	6			
MAP40R-FM80-2707		80	25.4	27	50	7			
MAP40R-FM100-3208		100	31.75	32	50	8			
MAP40R-FM125-4009		125	38.1	40	55	9			
MAP40R-FM160-4010		160	50.8	40	63	10			

● 訂購時請註明內孔 (d) 尺寸
Please note the diameter of 'd' when you order.



Square Shoulder Milling Cutter
方肩銑刀桿

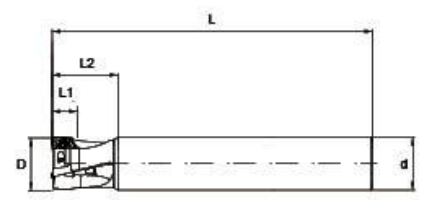

Square Shoulder Milling Cutter
方肩銑刀桿

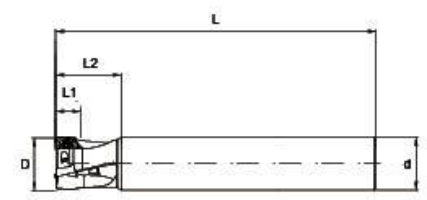

ITEM	產品代號	SPECIFICATION 規格				TEETH 刃數	INSERT 刀片型號	SCREW 刀片螺絲	WRENCH 扳手
		D	d	L1	L				
GLM10-1016-90		10			90	1	APLX-1003	SCR-M2.5	T8
GLM10-1216-90		12	16	25	90	1			
GLM10-1616-100		16			100	2			
GLM10-1616-150		16	150	2					
GLM10-2020-100		20	100	3					
GLM10-2020-150		20	20	27	150	3			
GLM10-2020-200		20	200	3					
GLM16-2525-120		25			120	2			
GLM16-2525-150		25	25	42	150	2			
GLM16-2525-200		25			200	2			
GLM16-2525-250		25			250	2			

ITEM	產品代號	SPECIFICATION 規格				TEETH 刃數	INSERT 刀片型號	SCREW 刀片螺絲	WRENCH 扳手
		D	d	L1	L				
HHU10-1616-120		16	16	30	120	2	JDMT1003	SCR-HHU2.5	T8
HHU10-1616-150		16	16	50	150	2			
HHU10-1716-175		17	16	50	175	2			
HHU10-1716-200		17	16	50	200	2			
HHU10-2020-130		20	20	30	130	3			
HHU10-2020-150		20	20	50	150	3			
HHU10-2120-200		21	20	30	200	3			
HHU10-2525-150		25	25	40	150	4			
HHU10-2525-200		25	25	60	200	4			
HHU10-2625-200		26	25	35	200	4			
HHU10-3232-150		32	32	40	150	5			
HHU15-2525-150		25	25	40	150	2			
HHU15-2525-200		25	25	60	200	2			
HHU15-2625-200		26	25	60	200	2			
HHU15-3025-150		30	25	40	150	2			
HHU15-3025-200		30	25	40	200	2			
HHU15-3232-150		32	32	40	150	3			
HHU15-3232-200		32	32	60	200	3			
HHU15-3332-200		33	32	60	200	3			
HHU15-3532-150		35	32	40	150	3			
HHU15-3532-200		35	32	60	200	3			



Square Shoulder Milling Cutter
方肩銑刀桿

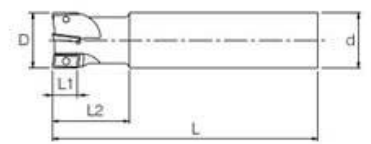

Threaded Shoulder Cutting End Mill
鎖牙式直角銑刀頭

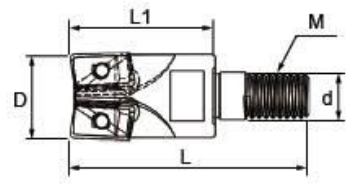

ITEM	產品代號	SPECIFICATION 規格 (mm)					TEETH 刃數	INSERT 刀片型號	SCREW 刀片螺絲	WRENCH 扳手
		D	d	L1	L2	L				
HEX-1212-120		12	12		25	120	1	APET1202	SCR-HEX3.5	T15
HEX-1212-150		12	12		25	150	1			
HEX-1216-100		12	16		20	100	1			
HEX-1616-120		16	16		30	120	1			
HEX-1616-150		16	16		30	150	1			
HEX-1616-180		16	16	12	30	180	1			
HEX-2020-120		20	20		30	120	1			
HEX-2020-150		20	20		30	150	2			
HEX-2020-200		20	20		30	200	2			
HEX-2120-200		21	20		30	200	2			
HEX-2525-130		25	25		35	130	2			
HEX-2525-160		25	25		35	160	2			
HEX-2525-200		25	25		35	200	2			
HEX-2525-250		25	25		35	250	2			
HEX-3025-150		30	25	15	45	150	2			
HEX-3232-150		32	32		45	150	3			
HEX-3232-200		32	32		45	200	3			
HEX-3232-250		32	32		45	250	3			
HEX-3332-200		33	32		35	200	3			
							ADET1603	SCR-HEX4		

ITEM	產品代號	SPECIFICATION 規格 (mm)					INSERT 刀片型號	SCREW 刀片螺絲	WRENCH 扳手
		D	d	L1	L	M			
HEX-0816-12.1		16	8.5	25	42	M8	APNT1202	SCR-HEX3.5	T15
HEX-0817-12.1		17	8.5	25	42	M8			
HEX-1020-12.2		20	10.5	30	42	M10			
HEX-1021-12.2		21	10.5	30	42	M10			
HEX-1225-16.2		25	12.5	35	57	M12	ADNT1603	SCR-HEX4.0	T15
HEX-1226-16.2		26	12.5	35	57	M12			
HEX-1230-16.2		30	12.5	35	57	M12			
HEX-1632-16.3		32	17	37	60	M16			
HEX-1633-16.3		33	17	37	60	M16			
HEX-1635-16.3		35	17	37	60	M16			
						APET1603			



Square Shoulder Milling Cutter
方肩銑刀桿

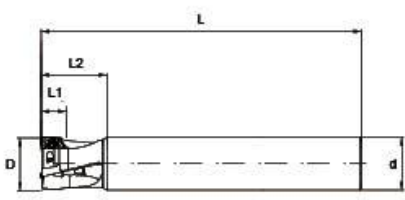

Square Shoulder Milling Cutter
方肩銑刀桿

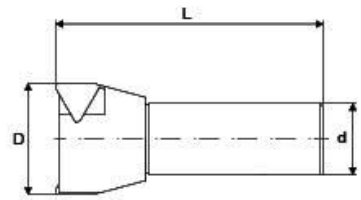

ITEM	產品代號	SPECIFICATION 規格 (mm)				TEETH 刃數	INSERT 刀片型號	SCREW 刀片螺絲	WALDOCH 牌子
		D	d	L1	L				
NSEM10-1010-100		10	10	20	100	1	APMT1035	SCR-NSEM2.5	T8
NSEM10-1012-100		10	12	25	100	1			
NSEM10-1212-100		12	12	25	100	1			
NSEM10-1416-100		14	16	25	100	1			
NSEM10-1616-100		16	16	25	100	2			
NSEM10-1616-120		16	16	25	120	2			
NSEM10-2020-110		20	20	30	120	3			
NSEM10-2020-150		20	20	50	150	3			
NSEM10-2525-150		25	25	35 60	150	4			
NSEM16-2525-150		25	25	40 60	150	2			
NSEM16-2525-220		25	25	40	220	2			
NSEM16-3232-150		32	32	35 45	150	3 2			
NSEM16-3232-200		32	32	35	200	3			
NSEM16-3232-250		32	32	35 45	250	3 2			
NSEM16-3532-150		35	32	45	150	3			
NSEM16-3532-250		35	32	45	250	3			
NSEM16-4032-135		40	32	45	135	3			
NSEM16-5032-135		50	32	45	135	4			
NSEM16-5032-150		50	32	45	150	4			

ITEM	產品代號	SPECIFICATION 規格 (mm)			TEETH 刃數	INSERT 刀片型號	SCREW 刀片螺絲	WALDOCH 牌子
		D	M	L				
GTP11-1616-110		16	16	110	1	TPMN1103	SCR-W3/16	WRN-M3L
GTP11-2020-110		20	20	110	2			
GTP11-2525-110		25	25	110	2			
GTP16-3020-130		30	20	130	2			
GTP16-3025-130		30	25	130	2			
GTP16-3520-130		35	20	130	2			
GTP16-3525-130		35	25	130	2			
GTP16-3532-150		35	32	150	2			
GTP16-4020-130		40	20	130	3			
GTP16-4025-130		40	25	130	3			
GTP16-4032-150		40	32	150	3			
GTP16-4520-130		45	20	130	3			
GTP16-4525-130		45	25	130	3			
GTP16-4532-150		45	32	150	3			
GTP16-5020-130		50	20	130	3			
GTP16-5025-130		50	25	130	3			
GTP16-5032-150		50	32	150	3			
GTP16-5032-200		50	32	200	3			
GTP16-6332-150		63	32	150	4			
GTP22-5032-150		50	32	150	2			
GTP22-6332-150		63	32	150	3			
GTP22-6332-150		63	32	150	3			



Square Shoulder Milling Cutter
方肩銑刀盤

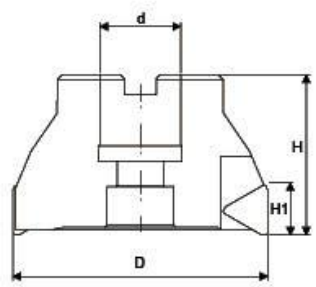

ITEM	產品代號	SPECIFICATION					TEST#	INSERT	SCREW	WRENCH
		D	d	d*	H1	H				
GTP16-50W/S-2203		50	-	22	16	50	3	TPMN1G03	SCR-W1/4	WRN-M4L
GTP16-63W/S-2204		63	25.4				4			

● 訂購時請註明內孔 (d) 尺寸
Please note the diameter of "d" when you order.



Square Shoulder Milling Cutter
方肩銑刀盤

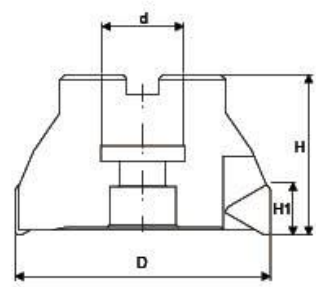

ITEM	產品代號	SPECIFICATION					TEST#	INSERT	INSERT SCR	SHM	SHM SCR	WRENCH
		D	d	d*	H1	H						
GTP22-FMG3-2703		63	25.4	27			3				WRN-M5L	
GTP22-FM80-2704		80	25.4	27			4					
GTP22-FM100-3205		100	31.75	32			5					
GTP22-FM125-4006		125	38.1	40			6					
GTP22-FM160-4007		160	50.8	40		22	7	TPKN2204	SCR-W5/16	ST-T	SCR-ST-T4	
GTP22-FM200-6008		200	47.625	60			8					
GTP22-FM250-6009		250	47.625	60			9					
GTP22-FM300-6010		300	47.625	60			10					

● 訂購時請註明內孔 (d) 尺寸
Please note the diameter of "d" when you order.

45° Face Milling Cutter
45度平面銑刀盤

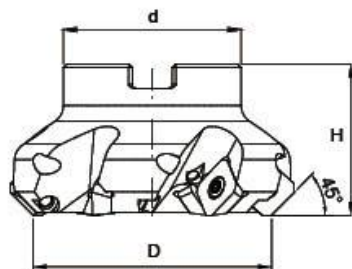

ITEM	產品代號	SPECIFICATION			TEETH 刃數	INSERT 刀片型號	SCREW 刀片螺絲	WRENCH 扳手
		D	d	H				
ASE-FM50.22-124A		50	22	40	4	SE.1204	SCR-ASE4M	T15
ASE-FM63.22-125A		G3	22		5			
ASE-FM80.27-126A		80	27	45	6			
ASE-FM100.32-127A		100	32	50	7			
ASE-FM125.40-128A		125	40	60	8			

45° Face Milling Cutter
45度平面銑刀盤

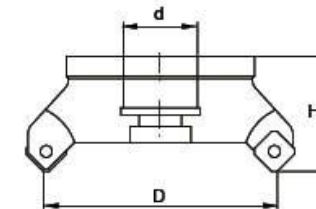

ITEM	產品代號	SPECIFICATION				TEETH 刃數	INSERT 刀片型號	SCREW 刀片螺絲	WRENCH 扳手
		D	d	d*	H				
WC403-FM50-2204		50	-	22	40	4	SNMX1205	SCR-SN4	T15
WC403-FM63-2206		G3	25.4	22	50	6			
WC403-FM80-2706		80	25.4	27	6				
WC403-FM100-3208		100	31.75	32	8				
WC403-FM125-4010		125	38.1	40	10				
WC403-FM160-4012		160	50.8	40	12				
WC403-FM200-6018		200	47.625	60	18				

● 訂購時請註明內孔 (d) 尺寸
Please note the diameter of "d" when you order.

45° Face Milling Cutter
45度平面銑刀盤

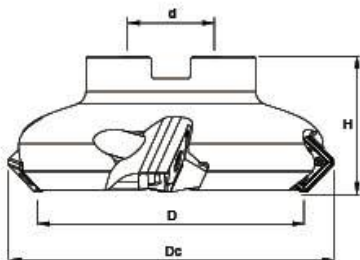

Face Milling

ITEM	產品代號	SPECIFICATION				TEETH 刃數	INSERT 刀片型號	SCREW 刀片螺絲	WRENCH 扳手
		Ø	d	α°	H				
MSSE13-FM63-2205		63	25.4	22	50	5	SEMT13T3	SCR-MSSE3	T15
MSSE13-FM80-2706		80	25.4	27	55				
MSSE13-FM100-3206		100	31.75	32	60				
MSSE13-FM125-4008		125	38.1	40	8				
MSSE13-FM150-4010		150	50.8	40	10				
MSSE13-FM200-6012		200	47.625	60	12				

● 訂購時請註明內孔 (d) 尺寸
Please note the diameter of "d" when you order.

45° Face Milling Cutter
45度平面銑刀桿

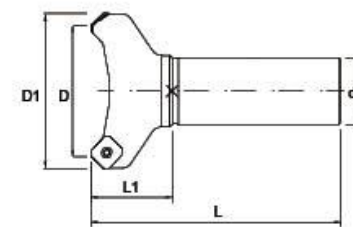

Face Milling

ITEM	產品代號	SPECIFICATION						TEETH 刃數	INSERT 刀片型號	SCREW 刀片螺絲	WRENCH 扳手
		Ø	D1	d	L1	L	mm				
GSET12-5025-120		50	62	25	45	120	4	SEKT1204	SCR-GSE5	T20	
GSET12-5032-150		50	62	32		150					
GSET12-6325-120		63	74	25		120					
GSET12-6332-150		63	74	32		150					

45° Face Milling Cutter
45度平面銑刀盤

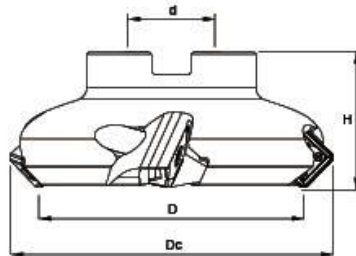

Face Milling

ITEM	產品代號	SPECIFICATION 規格 (mm)				TEETH 刃數	INSERT 刀片型號	SCREW 刀片螺絲	WHLNCR 銑子
		D	Do	d	d°				
GSET12-FM50-2204		50	64	-	22	45	SEKT1204	SCR-GSE5	T20
GSET12-FMG3-2705		63	77	25.4	27	50			
GSET12-FM80-2706		80	94	25.4	27	6			
GSET12-FM100-3206		100	114	31.75	32	55			
GSET12-FM125-4008		125	139	38.1	40	6			
GSET12-FM160-4010		160	174	50.8	40	8			
GSET12-FM200-6012		200	214	47.625	60	10			
GSET12-FM250-6014		250	264	47.625	60	12			
						14			

● 訂購時請註明內孔 (d) 尺寸
Please note the diameter of "d" when you order.

45° Face Milling Cutter
45度平面銑刀桿

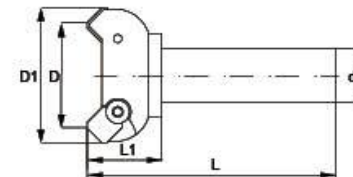

Face Milling

ITEM	產品代號	SPECIFICATION 規格 (mm)					TEETH 刃數	INSERT 刀片型號	SCREW 刀片螺絲	WHLNCR 銑子
		D	D1	d	L1	L				
GSEN12-5025-150		50	62	25			3	SEKN1203	SCR-W1/4L	WRN-ML
GSEN12-5032-150		50	62	32	45	150	3			
GSEN12-6325-150		63	74	25			4			
GSEN12-6332-150		63	74	32			4			

45° Face Milling Cutter
45度平面銑刀盤

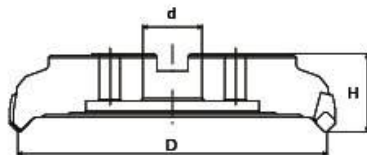

Face Milling

45° Face Milling Cutter For Aluminium
45度可調式平面鋁合金刀盤

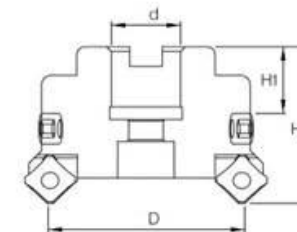

Face Milling

ITEM 產品代號	SPECIFICATION 規格 mm				TEETH 刃數	INSERT 刀片型號	CLAMP 壓板	CLAMP SCR 壓板螺絲	SHIM 墊片	SHIM SCR 墊片螺絲	WRENCH 扳手
	D	d	d ^o	H							
GSEN12-FM80-2705	80	25.4	27	50	5	SEKN1203	CL4-S				
GSEN12-FM100-3205	100	31.75	32	55	5						
GSEN12-FM125-4006	125	38.1	40		6						
GSEN12-FM160-4008	160	50.8	40		8						
GSEN12-FM200-6010	200	47.625	60	60	10						
GSEN12-FM250-6012	250	47.625	60		12						
GSEN12-FM300-6014	300	47.625	60		14						
GSEN15-FM80-2705	80	25.4	27	50	5	SEKN1504	CL5-S	SCR-CL5/16	ST-S	SCR-ST-S4	WRN-M4T
GSEN15-FM100-3205	100	31.75	32	55	5						
GSEN15-FM125-4006	125	38.1	40		6						
GSEN15-FM160-4008	160	50.8	40		8						
GSEN15-FM200-6010	200	47.625	60	60	10						
GSEN15-FM250-6012	250	47.625	60		12						
GSEN15-FM300-6014	300	47.625	60		14						

● 訂購時請註明內孔 (d) 尺寸
Please note the diameter of "d" when you order.

ITEM 產品代號	SPECIFICATION 規格 mm				TEETH 刃數	INSERT 刀片型號	INSERT SCR 刀片螺絲	CLAMP 壓板	CASSETTESCR 刀片螺絲	WRENCH 扳手
	D	d	H1	H						
AFC-FM63.22-124T	63	22	22		4	SE.1204	SC5001	AFC01	CS6001	T20
AFC-FM80.22-124T	80	22	23		4					
AFC-FM100.27-126T	100	27	28	50	6					
AFC-FM125.32-128T	125	32	28		8					
AFC-FM160.40-128T	160	40	32		8					
AFC-FM200.40-1210T	200	40	32	55	10					
AFC-FM250.40-1210T	250	40	32		10					

65° Face Milling Cutter
65度平面銑刀盤

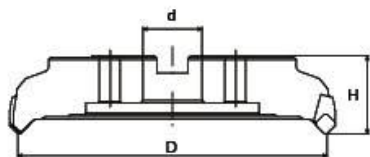

Face Milling

75° Face Milling Cutter
75度平面銑刀盤

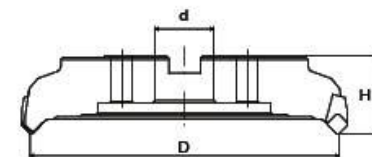

Face Milling

ITEM 產品代號	SPECIFICATION 規格 (mm)				TEETH 刃數	INSERT 刀片型號	CLAMP 壓板	CLAMP SCR 壓板螺絲	SHIM 墊片	SHIM SCR 墊片螺絲	WALNUT 螺母
	D	d	d*	H							
GSPK12-FM00-2705	80	25.4	27	50	5						
GSPK12-FM100-3205	100	31.75	32	55	5						
GSPK12-FM125-4006	125	38.1	40		6						
GSPK12-FM160-4008	160	50.8	40		8	SPKN1204	CL4-S				
GSPK12-FM200-6010	200	47.625	60	60	10						
GSPK12-FM250-6012	250	47.625	60		12						
GSPK12-FM300-6014	300	47.625	60		14			SCR-CL5/16	ST-S	SCR-ST-S4	WRN-MAT
GSPK15-FM00-2705	80	25.4	27	50	5						
GSPK15-FM100-3205	100	31.75	32	55	5						
GSPK15-FM125-4006	125	38.1	40		6						
GSPK15-FM160-4008	160	50.8	40		8	SPKN1504	CL5-S				
GSPK15-FM200-6010	200	47.625	60	60	10						
GSPK15-FM250-6012	250	47.625	60		12						
GSPK15-FM300-6014	300	47.625	60		14						

● 訂購時請註明內孔 (d) 尺寸
Please note the diameter of "d" when you order.

ITEM 產品代號	SPECIFICATION 規格 (mm)				TEETH 刃數	INSERT 刀片型號	CLAMP 壓板	CLAMP SCR 壓板螺絲	SHIM 墊片	SHIM SCR 墊片螺絲	WALNUT 螺母
	D	d	d*	H							
GSPU12-FM80-2705	80	25.4	27	50	5						
GSPU12-FM100-3206	100	31.75	32	55	6						
GSPU12-FM125-4008	125	38.1	40	60	8						
GSPU12-FM160-4010	160	50.8	40	60	10	SPUN1203	CL-S	SCR-CL5/16	ST-S	SCR-ST-S4	WRN-MAT
GSPU12-FM200-6012	200	47.625	60	60	12						
GSPU12-FM250-6016	250	47.625	60	60	16						
GSPU12-FM300-6020	300	47.625	60	60	20						

● 訂購時請註明內孔 (d) 尺寸
Please note the diameter of "d" when you order.

日隆精技

RI HSIUNG
PRECISION
TECH

Octagon Face Milling Cutter 八角平面銑刀盤

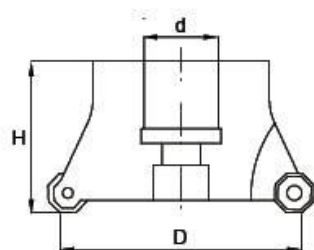

Face Milling

ITEM	產品代號	SPECIFICATION 規格				TEETH 刃數	INSERT 刀片型號	SCREW 刀片螺絲	WRENCH 扳手
		D	d	d*	H				
OFC05-FM50-2204		50	-	22	40	4	ODMT0504	SCR-WC3.5	T15
OFC05-FM63-2206		63	25.4	22	45	6			
OFC05-FM80-2707		80	25.4	27	50	7			
OFC05-FM100-3208		100	31.75	32	50	8			
OFC05-FM125-4010		125	38.1	40	63	10			
OFC05-FM160-4012		160	50.8	40	63	12			
OFC05-FM200-6014		200	47.625	60	63	14			

● 訂購時請註明內孔 (d) 尺寸

Please note the diameter of "d" when you order.

日隆精技

RI HSIUNG
PRECISION
TECH

High-Feed Milling Cutter 鎖牙式高速進給銑刀頭

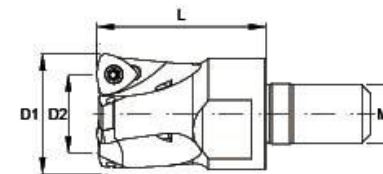

High-Feed

ITEM	產品代號	SPECIFICATION 規格				TEETH 刃數	INSERT 刀片型號	SCREW 刀片螺絲	WRENCH 扳手
		D1	D2	M	L				
AHF-2010-2A.100		20	11.4	M10	28	2	218.19-100	SCR-M2.5	T8
AHF-2512-3A.100		25	16.4	M12	35	3			
AHF-3216-3A.125		32	21	M16	40	3	218.19-125	SCR-CSJ3	T9
AHF-4016-4A.125		40	29	M16		4			

High-Feed Milling Cutter
高速進給銑刀盤

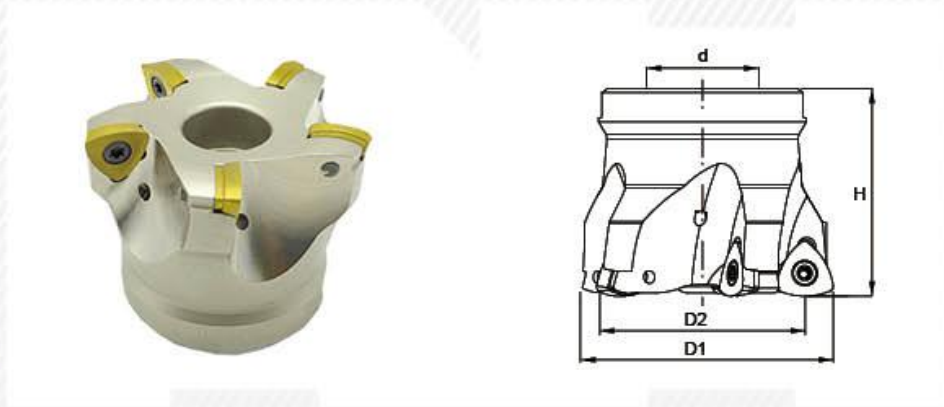

High-Feed

ITEM	產品代號	SPECIFICATION				TEST# 刃數	INSERT 刀片型號	SCREW 刀片螺絲	WHLNCH 銑手
		D1	D2	d	H				
AHF-FM40.16-1254A		40	29	16	4	218.19-125	SCR-CSJ3	T9	
AHF-FM50.22-1604A		50	36	22	4	218.19-160	SCR-R4M	T15	
AHFFMG3.27-1605A		63	49.5	27	5				
AHF-FM80.27-1606A		80	66.5	27	6				
AHF-FM100.32-1607A		100	86.5	32	7				

High-Feed Milling Cutter
高速進給銑刀桿

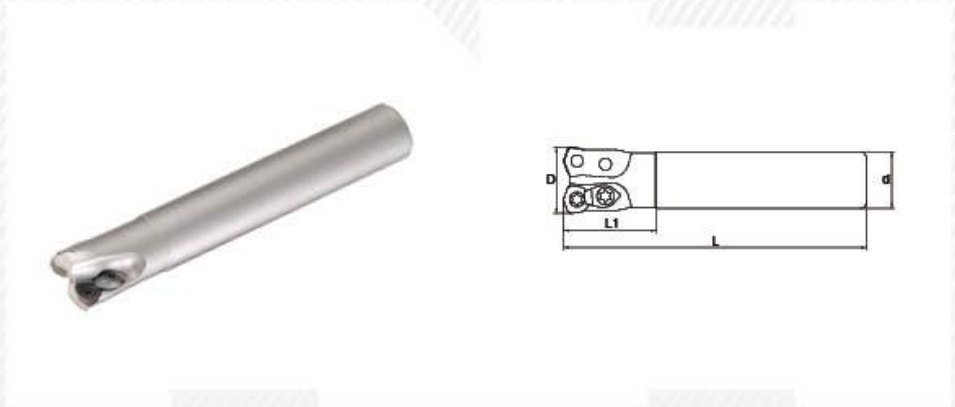

High-Feed

ITEM	產品代號	SPECIFICATION				TEST# 刃數	INSERT 刀片型號	INSERT SCR 刀片螺絲	CLAMP 壓板	CLAMP SCR 壓板螺絲	WHLNCH 銑手
		D	d	L	L1						
JHF-2525-092		25	25	150	35	2	JD..09T3	SC-351	CM03	CSC3510	T15
JHF-2825-092		28	25	150	35	2					
JHF-3025-122		30	25	150	35	2	JD..1204	SC-4008	CM04	CSC4012	
JHF-3232-122		32	32	150	35	2					
JHF-3532-122		35	32	150	35	2					
JHF-4032-123		40	32	170	47	3					
JHF-5032-124		50	32	170	50	4	JD..1405	SC-501	CM05	CSC5014	T20
JHF-G342-144		63	42	200	50	4					

High-Feed Milling Cutter 高速進給銑刀盤

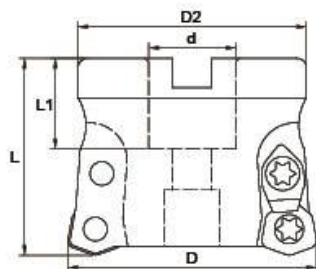

High-Feed Milling Cutter 高速進給銑刀桿

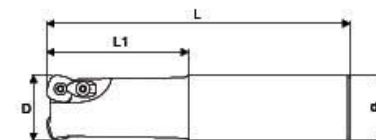

High-Feed

High-Feed

ITEM 產品代號	SPECIFICATION 規格 (mm)					TEETH 刃數	INSERT 刀片型號	INSERT SIZE 刀片規格	CLAMP 壓鉗	BLIM SCR. 輪片螺絲	WRENCH 扳手
	D	d	D2	L	L1						
JHF-FM50.22-124	50	22	45			4	JD...1204	SC-4008	CM04	CSC-4012	T15
JHF-FM63.22-124	63	22	58	50	23	4					
JHF-FM80.27-125	80	27	65	55	26	5	JD...1405	SC-501	CM05	CSC-5014	T20
JHF-FM100.32-126	100	32	80			6					

ITEM 產品代號	SPECIFICATION 規格 (mm)				TEETH 刃數	INSERT 刀片型號	INSERT SIZE 刀片規格	CLAMP 壓鉗	CLAMP SCR. 壓鉗螺絲	WRENCH 扳手
	D	d	L1	L						
HRF12-3232-150	32	32		150	2					
HRF12-3232-200	32	32		200	2					
HRF12-4032-200	40	32	70	200	3	SDNW1205	SCR-HRF4	CL-HRF5	SCR-HRF4	T15
HRF12-4032-250	40	32		250	3					
HRF12-4032-300	40	32		300	3					

日精科技

RI HSIUNG
PRECISION
TECH

High-Feed Milling Cutter 高速進給銑刀盤

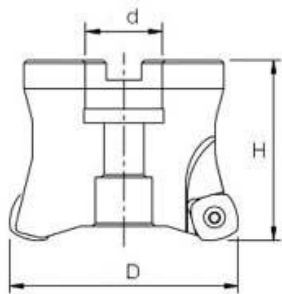

日精科技

RI HSIUNG
PRECISION
TECH

High-Feed Milling Cutter 高速進給銑刀桿



High-Feed

High-Feed

ITEM 產品代號	SPECIFICATION 規格				TEST# 刃數	INSERT 刀片型號	INSERT SCR 刀片螺絲	CLAMP 壓板	CLAMP SCR 壓板螺絲	WRENCH 扳手
	D	d	d*	H						
HRF12-FM63-2204	63	25.4	22	50	4					
HRF12-FM80-2705	80	31.75	27	70	5	SDNW1205	SCR-HRF4	CL-HRF5	SCR-HRF4	T15
HRF12-FM100-3206	100	31.75	32		6					

● 訂購時請註明內孔 (d) 尺寸
Please note the diameter of "d" when you order.

ITEM 產品代號	SPECIFICATION 規格				TEST# 刃數	INSERT 刀片型號	SCREW 刀片螺絲	WRENCH 扳手
	D	d	L1	L				
HSR06-1616-130	16	16	35	130	2			
HSR06-1616-180	16	16	50	180	2			
HSR06-1716-130	17	16	35	130	2			
HSR06-1716-180	17	16	35	180	2			
HSR06-2020-150	20	20	40	150	3			
HSR06-2020-200	20	20	80	200	3			
HSR06-2120-150	21	20	40	150	3			
HSR06-2120-200	21	20	35	200	3			
HSR06-2525-150	25	25	50	150	4			
HSR06-2525-200	25	25	100	200	4			
HSR06-2625-150	26	25	40	150	4			
HSR06-2625-200	26	25	35	200	4			
HSR06-3032-150	30	32	40	150	4			
HSR06-3032-200	30	32	100	200	4			
HSR06-3232-150	32	32	40	150	5			
HSR06-3232-200	32	32	100	200	5			
HSR06-3532-150	35	32	45	150	5			
HSR06-4032-170	40	32	45	170	6			
HSR06-4032-220	40	32	45	220	6			

EPNW0G03 SCR-HSR2.5 T8

High-Feed Milling Modular Cutter 鎖牙式高速進給銑刀頭

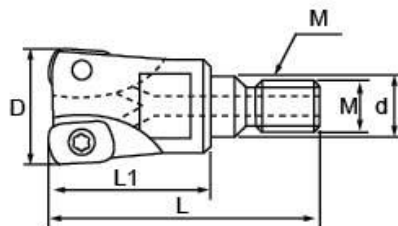

High-Feed

ITEM	產品代號	SPECIFICATION					TEETH 刃數	INSERT 刀片型號	SCREW 刀片螺絲	WRENCH 扳手
		D	d	L1	L	M				
HSR-0816-06.2A		16	8.5	26	43	M08	2	EPNW0603	SCR-HSR2.5	T8
HSR-0817-06.2A		17	8.5	26	43	M08	2			
HSR-1020-06.3A		20	10.5	32	50	M10	3			
HSR-1021-06.3A		21	10.5	32	50	M10	3			
HSR-1225-06.4A		25	12.5	38	60	M12	4			
HSR-1226-06.4A		26	12.5	32	60	M12	4			
HSR-1632-06.5A		32	17	41	63	M16	5			
HSR-1635-06.5A		35	17	41	63	M16	5			
HSR-1640-06.5A		40	17	41	63	M16	5			
HSR-2550-06.6A		50	36	60	100	M25	6			
HSR-2563-06.7A		63	36	60	100	M25	7			

High-Feed Milling Cutter 高速進給銑刀桿

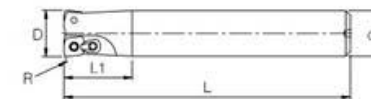

High-Feed

ITEM	產品代號	SPECIFICATION					TEETH 刃數	INSERT 刀片型號	INSERT SCR 刀片螺絲	CLAMP 壓板	SHIM SCR 墊片螺絲	WRENCH 扳手
		D	d	R	L1	L						
HSR08-2020-130		20	20	10	50	130	2	EPNW0803	SCR-HSR3.5			
HSR10-2525-140		25	25		60	140	2	EDNW10T4	SCR-HSR4	CL-HSR3.5	SCR-HSR3.5	T15
HSR10-2525-200		25	25		120	200	2					
HSR13-3232-150		32	32	15	70	150	2	EDNW13T4	SCR-HSR5	CL-HSR5	SCR-HSR5	T20
HSR13-3232-200		32	32		120	200	2					
HSR13-3232-300		32	32		180	300	2					
HSR13-3332-200		33	32		200	200	2					
HSR13-3532-150		35	32			150	2					
HSR13-3532-200		35	32	50	200	2						
HSR13-3532-250		35	32		250	2						

High-Feed Milling Cutter 高速進給銑刀盤

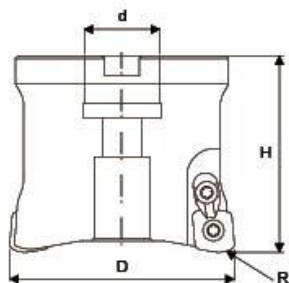

High-Feed

ITEM	產品代號	SPECIFICATION				測 長 (mm)	夾 緊 力	夾 緊 螺 絲	夾 緊 螺 絲 規 格	夾 緊 螺 絲 規 格	夾 緊 螺 絲 規 格
		D	d	d*	R						
ESR13-FM50-2204		50	25.4	22	50	3/4	EDNW13T4				
ESR15-FM63-2204		63	25.4	22							
ESR15-FM66-2204		66	25.4	22	15(10)	4		CL-ESR5	SCR-ESR5	T20	
ESR15-FM80-2705		80	25.4	27	70	5					
ESR15-FM100-3206		100	31.75	32	6						

● 訂購時請註明內孔 (d) 尺寸
Please note the diameter of "d" when you order.

Helical Milling Cutter 螺旋銑刀桿

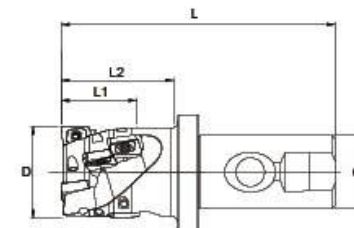

Helical & Drilling

ITEM	產品代號	SPECIFICATION					測 長 (mm)	夾 緊 力	夾 緊 螺 絲	夾 緊 螺 絲 規 格	夾 緊 螺 絲 規 格
		D	d	L1	L2	L					
AXO-2525-33-121-122A		25	25	33	56	121	2	XO.1204	SCR-XO3.5	T10	
AXO-2532-44-125-123A		32	25	44	60	125	3				
AXO-3240-44-130-123A		40	32	44	60	130	3				

Helical & Drilling

Helical Milling Cutter
螺旋銑刀頭

SKD Ni SC

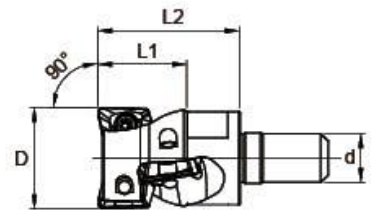

Helical Milling Cutter
螺旋銑刀桿

SAE SKD Ni OX IWT HT

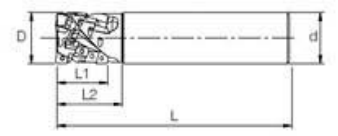

Helical & Drilling

ITEM	產品代號	SPECIFICATION 規格 (mm)				TEETH 刃數	INSERT 刀片型號	SCREW 刀片螺絲	WRENCH 扳手
		D	d	L1	L2				
AXO-1225-2243-12.2A		25	M12	22	43	2	XO.1204	SCR-XO3.5	T10
AXO-1632-2243-12.3A		32	M16	22	43	3			
AXO-1640-3357-12.3A		40	M16	33	57	3			

Helical & Drilling

ITEM	產品代號	SPECIFICATION 規格 (mm)					FLUTE 槽數	INSERT 刀片	PCS 刀片數	INSERT 刀片	PCS 刀片數	SCREW 刀片螺絲	WRENCH 扳手
		D	d	L1	L2	L							
WHGH-3242-150		32	32	42	70	150	2	LPMT 15T3	1	SDNT 0903	5	SCR-WHGH4	T15
WHGH-4050-155		40	32	50	75	155	4	LPMT 1504	2	SPMT 1204	12	SCR-WHGH5	T20
WHGH-5077-205		50	50.8	77	115	205	4		2		14		
WHGH-5097-225		50	50.8	97	135	225	4		2		18		
WHGH-50127-255		50	50.8	127	165	255	4		2		24		
WHGH-50157-285		50	50.8	157	195	285	4		2		30		

Helical Milling Cutter
螺旋銑刀桿

SAE SKD Ni OX
WT HT

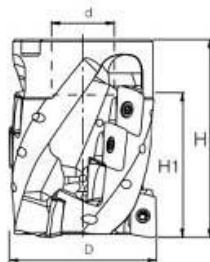

Helical Milling Cutter
一體式螺旋銑刀桿

SAE SKD Ni OX
WT HT

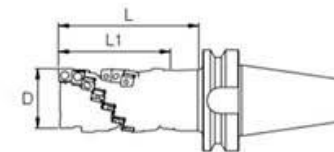

ITEM 產品代號	SPECIFICATION 規格 (mm)				FLUTE 槽數	INSERT 刀片	PCS	INSERT 刀片	PCS	SCREW 刀片螺絲	W/BLANK 板子
	D	d	H1	H							
WHGH-50-22	50	22	42	69	3		3		6		
WHGH-63-25.4	63	25.4	68	69	3	APKT 1604	4	APKT 1604	8	SCR- 4004	T15
WHGH-63-25.4	63	25.4	68	97	5		4		16		
WHGH-80-31.75	80	31.75	67	80	6	LPMT 1504	3	SPMT 1204	18	SCR- WHGH5	T20
WHGH-80-32	80	32									

ITEM 產品代號	SPECIFICATION 規格 (mm)			FLUTE 槽數	INSERT 刀片	PCS	SCREW 刀片螺絲	W/BLANK 板子	
	D	L1	L						
BT50-050.100.Z3-04232	50		194	3	SP.1204	30	SCR-5004	T20	
BT50-050.100.Z3-04248	50	100	207						
BT50-050.100.Z3-06232	50		191						
BT50-050.100.Z3-06248	50		207						
BT50-050.158.Z3-04232	50	158	191						
BT50-050.158.Z3-06232	50								
BT50-063.200.Z3-04290	63	200	249						
BT50-063.200.Z3-04348	63	260	307						
BT50-080.200.Z4-04290	80	200	249		4	SP.1204	57		SCR-5004
							75		
						76			

Drilling & Milling Cutter
鑽銑刀桿

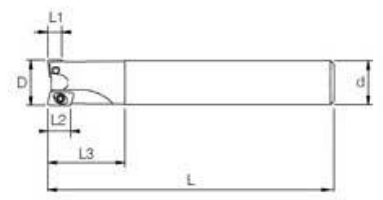

Drilling & Milling Cutter
鑽銑刀桿

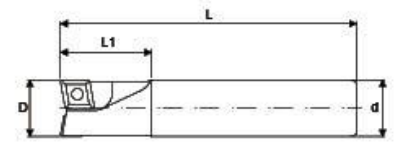

Helical & Drilling

ITEM	產品代號	SPECIFICATION 規格 (mm)				TEETH 刃數	PCS	INSERT 刀片型號	PCS	SCREW 刀片螺絲	WALNUT 螺母
	D	d	L1	L2	L3	L					
HJ2-1616-120	16	16			33	120					
HJ2-1616-175	16	16	4.5	8.5	50	175	JDMT 080300L	1	JDMT 080300R	T6	
HJ2-1716-120	17	16			33	120			SCR-HJ2		
HJ2-1716-175	17	16			33	175					
HJ2-2020-130	20	20			35	130					
HJ2-2020-185	20	20	5.5	9.5	60	185	JDMT 100300L	1	JDMT 100300R	T8	
HJ2-2120-130	21	20			35	130			SCR-HJ2		
HJ2-2120-185	21	20			35	185					
HJ2-2525-140	25	25			45	140					
HJ2-2525-220	25	25	7	12.5	75	220	JDMT 12T300L	1	JDMT 12T300R	T10	
HJ2-2625-140	26	25			45	140					
HJ2-2625-220	26	25			45	220					
HJ2-3232-150	32	32			50	150					
HJ2-3232-230	32	32	8	14.5	90	230	JDMT 160500L	1	JDMT 160500R	T15	
HJ2-3332-150	33	32			50	150					
HJ2-3332-230	33	32			50	230					

Helical & Drilling

ITEM	產品代號	SPECIFICATION 規格 (mm)				TEETH 刃數	INSERT 刀片型號	PCS	SCREW 刀片螺絲	WALNUT 螺母
	D	d	L1	L						
HJU-1010-130	10	10	30	130	1	CCMT0602				
HJU-1012-130	10	12	35	130	1	CPMT0802				
HJU-1212-130	12	12	30	130	1	CPMT0802				
HJU-1616-120	16	16	30	120	2	CCMT0602	SCR-HJU2.5	T8		
HJU-1616-150	16	16	40	150	2	CCMT0602				
HJU-1616-175	16	16	40	175	2	CPMT0802				
HJU-1616-200	16	16	40	200	2	CPMT0802				
HJU-1716-175	17	16	40	175	2					
HJU-1716-200	17	16	40	200	2					
HJU-2020-130	20	20	30	130	2					
HJU-2020-150	20	20	40	150	2	CCMT0602	SCR-HJU2.5	T8		
HJU-2020-185	20	20	50	185	2	CPMT0802	SCR-HJU3.5	T15		
HJU-2120-150	21	20	40	150	2	CPMT0802				
HJU-2120-200	21	20	40	200	2					
HJU-2525-130	25	25	40	130	2					
HJU-2525-150	25	25	50	150	2	CPMT0903	SCR-HJU4	T15		
HJU-2525-220	25	25	70	220	2	CPMT1203				
HJU-2625-200	26	25	50	200	2					
HJU-2625-250	26	25	50	250	2					
HJU-3232-170	32	32	50	170	2					
HJU-3232-250	32	32	80	250	2					
HJU-3232-300	32	32	80	300	2	CPMT1204	SCR-HJU5	T20		
HJU-3232-350	32	32	80	350	2	CPMT1604				
HJU-3332-250	33	32	50	250	2					
HJU-3332-300	33	32	50	300	2					

45° Chamfering Milling Cutter
45度倒角刀桿

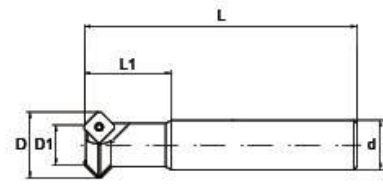

45° Chamfering Milling Cutter
45度倒角刀桿

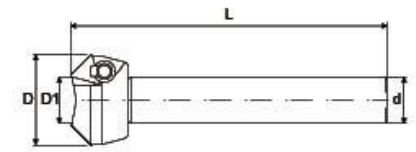

Chamfering & T-Slot

ITEM	產品代號	SPECIFICATION				TEST# 刃數	INSERT 刀片型號	SCREW 刀片螺絲	WRENCH 扳手
		D	D1	L1	L				
CM2-1510-120-C1205		15	10	20	120	12	SPMG0502	M2.0X5	T6
CM2-1711-90-C1205		17	11	23	90	12			
CM2-2215-100-C1606		22	15	30	100	16			
CM2-2718-120-C2007		27	18	35	120	20			
CM2-3019-150-C2009		30	19	40	150	20			
CM2-3222-120-C2009		32	22	43	120	20			
CM3-1711-90-C1205		17	11	23	90	12	SPMG0502	M2.0X5	T6
CM3-1913-150-C1605		19	13	30	150	16			
CM3-2215-100-C1606		22	15	30	100	16			
CM3-2718-120-C2007		27	18	35	120	20			
CM3-3222-120-C2009		32	22	43	120	20			
CM3-4029-150-C2509		40	29	40	150	25			
CM4-2418-150-C2005		24	18	35	150	20	SPMG0502	M2.0X5	T6
CM4-5039-150-C2509		40	39	40	150	25			

Chamfering & T-Slot

ITEM	產品代號	SPECIFICATION				TEST# 刃數	INSERT 刀片型號	SCREW 刀片螺絲	WRENCH 扳手
		D1	D	d	L				
CMT1-0521-16		5	21	16		1	TPUN1603	SCR-W1/4	WRN-M4L
CMT1-0521-20		5	21	20	120	1			
CMT2-1031-20		10	31	20		2			
CMT3-2050-25		20	50	25	130	3			
CMT3-2050-32		20	50	32		3			
CMT1-0632-32		6	32	32		1			
CMT3-3563-25		35	63	25	150	3			
CMT3-3563-32		35	63	32		3			

T-Slot Milling Cutter
T型槽銑刀桿

SAE SKD
NI OX
ISO SC

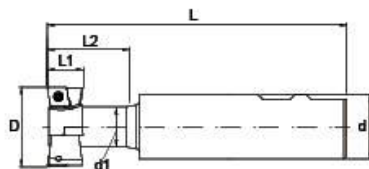

Disc Milling Cutter
側銑刀刀盤

SAE SKD
NI
SC

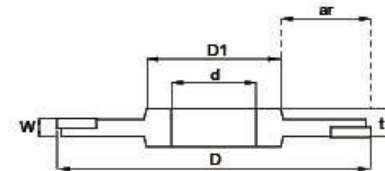

ITEM 產品代號	SPECIFICATION 規格 (mm)							TEETH 刃數	INSERT 刀片型號	SCREW 刀片螺絲	WHLNCH 柄子
	D	d	d1	L1	L2	L					
RTS06-1018-0802T	18	25	10	8	13	98	1*2				
RTS06-0919-0802T	19	25	9	8	20	105	1*2				
RTS06-12524-1002T	24	25	12.5	10	18	108	1*2	CCMT0602	SCR-2507	T8	
RTS06-12525-1102T	25	25	12.5	11	21	112	1*2				
RTS06-1327-1104T	27	32	13	11	26	115	2*2				
RTS08-13525-1201T	25	25	13.5	12	22	114	1*2				
RTS08-12528-1204T	28	25	12.5	12	21	113	2*2				
RTS08-1630-1304T	30	32	16	13	25	118	2*2	CCMT0803	SCR-3007	T10	
RTS08-1632-1304T	32	32	16	13	21	114	2*2				
RTS08-1632-1404T	32	32	16	14	30	120	2*2				
RTS09-1638-1404T	38	32	16	14	30	124	2*2				
RTS09-2040-1804T	40	32	20	18	32	130	2*2	CCMT09T3	SCR-4004	T15	
RTS09-1841-1704T	41	32	18	17	21	118	2*2				
RTS12-2042-2104T	42	32	20	21	23	124	2*2				
RTS12-2250-1504T	50	32	22	15	28	120	2*2	CCMT1204	SCR-5007	T20	
RTS12-2650-2204T	50	32	26	22	39	140	2*2				
RTS12-2657-2204T	57	32	26	22	38	140	2*2				

ITEM 產品代號	SPECIFICATION 規格 (mm)				TEETH 刃數	INSERT 刀片型號	SCREW 刀片螺絲	WHLNCH 柄子	
	D	D1	d	W					
DSC-100.04.1102A25				4	12	G*2	SN..1102	SC0350	T7
DSC-100.05.1103A25				5	12	G*2	SN..1103	SC0430	
DSC-100.06.1203A25	100			6	12	5*2	SN..1203	SC0500	T15
DSC-100.07.1203A25				7	12	3*3		SC0500	
DSC-100.08.1203A25				8	12	3*3		SC0500	
DSC-100.09.1205A25				9	12	4*2		SN..1205	
DSC-100.10.1205A25				10	12	5*2	SC0820		
DSC-100.12.1207A25				12	12	5*2	SN..1207	SC0110	
DSC-100.14.1207A25				14	12	3*3		SC0110	
DSC-125.04.1102A25				125	45	25.4	4	12	
DSC-125.05.1103A25	5	12	7*2				SN..1103	SC0430	
DSC-125.06.1203A25	6	12	G*2				SN..1203	SC0500	
DSC-125.07.1203A25	7	12	4*3					SC0500	
DSC-125.08.1203A25	8	12	4*3					SC0500	
DSC-125.09.1205A25	9	12	G*2					SN..1205	SC0820
DSC-125.10.1205A25	10	12	G*2				SC0820		
DSC-125.12.1207A25	12	12	G*2				SN..1207	SC0110	
DSC-125.14.1207A25	14	12	G*2	SC0110					
DSC-160.06.1203A25	160			6	12	8*2	SN..1203	SC0500	T15
DSC-160.07.1203A25				7	12	5*3		SC0500	
DSC-160.08.1203A25				8	12	5*3		SC0500	
DSC-160.09.1205A25				9	12	8*2		SN..1205	
DSC-160.10.1205A25				10	12	8*2	SC0820		
DSC-160.12.1207A25				12	12	8*2	SN..1207	SC0110	
DSC-160.14.1207A25				14	12	8*2		SC0110	

Disc Milling Cutter
側銑刀刀盤

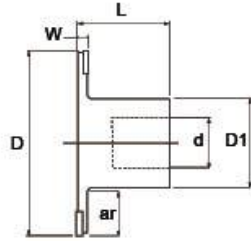

ITEM	產品代號	SPECIFICATION 規格 (mm)					TEETH 刃數	INSERT 刀片型號	SCREW 刀片螺絲	WRENCH 扳手
		D	D1	d	L1	L				
DSC-080.04.1102B22						4	5*2	SN.1102	SC0350	T7
DSC-080.05.1103B22						5	5*2	SN.1103	SC0430	
DSC-080.06.1203B22						6	4*2			
DSC-080.07.1203B22						7	3*3	SN.1203	SC0500	
DSC-080.08.1203B22						8	3*3			
DSC-080.09.1205B22						9	4*2			T15
DSC-080.10.1205B22						10	4*2	SN.1205	SC0820	
DSC-080.12.1207B22						12	4*2			
DSC-080.14.1207B22						14	3*3	SN.1207	SC0110	
DSC-100.04.1102B27						4	6*2	SN.1102	SC0350	T7
DSC-100.05.1103B27						5	6*2	SN.1103	SC0430	
DSC-100.06.1203B27						6	5*2			
DSC-100.07.1203B27						7	3*3	SN.1203	SC0500	
DSC-100.08.1205B27						8	3*3			
DSC-100.09.1205B27						9	5*2	SN.1205	SC0820	T15
DSC-100.10.1205B27						10	5*2			
DSC-100.12.1207B27						12	3*3			
DSC-100.14.1207B27						14	7*2	SN.1207	SC0110	
DSC-125.04.1102B32						4	7*2	SN.1102	SC0350	T7
DSC-125.05.1103B32						5	7*4	SN.1103	SC0430	
DSC-125.06.1203B32						6	4*3			
DSC-125.07.1203B32						7	4*3	SN.1203	SC0500	
DSC-125.08.1203B32						8	6*2			
DSC-125.09.1205B32						9	6*2	SN.1205	SC0820	T15
DSC-125.10.1205B32						10	6*2			
DSC-125.12.1207B32						12	4*3	SN.1207	SC0110	
DSC-125.14.1207B32						14	8*2			
DSC-160.06.1203B40						6	8*2			
DSC-160.07.1203B40						7	5*3	SN.1203	SC0500	
DSC-160.08.1203B40						8	5*3			
DSC-160.09.1205B40						9	8*2	SN.1205	SC0820	T15
DSC-160.10.1205B40						10	8*2			
DSC-160.12.1207B40						12	8*2			
DSC-160.14.1207B40						14	5*3	SN.1207	SC0110	

Bolt Countersink Milling Cutter
沉頭孔銑刀桿

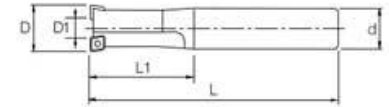

ITEM	產品代號	SPECIFICATION 規格 (mm)					TEETH 刃數	INSERT 刀片型號	SCREW 刀片螺絲	WRENCH 扳手
		D	D1	d	L1	L				
SCM-8-14-25		14	2.9	25	21	108	1			
SCM-10-17.5-25		17.5	5.3	25	26	115	2	CCMT0602	SCR-SCM2.5	T8
SCM-12-20-25		20	7.8	25	30	120	2			
SCM-14-23-25		23	10.8	25	34.5	126	2			
SCM-16-26-32		26	8.5	32	39	132	2			
SCM-18-29-32		29	11.5	32	43.5	138	2	CCMT0903	SCR-SCM3.5	T15
SCM-20-32-32		32	14.5	32	59	144	2			

Twin-Blade Boring Bar Cutter
固定式雙刃粗搪刀桿



Copy Milling Cutter
仿形銑刀桿

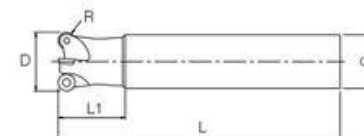

ITEM	產品代號	SPECIFICATION 規格 (mm)				TEETH 刃數	INSERT 刀片型號	SCREW 刀片螺絲	WHLNCH 柄中
		D	d	L1	L				
RTB-1412-100		13.8	12	25	100	1			
RTB-1516-100		14.7	16		100	2			
RTB-1616-100		15.7	16	50	100	2			
RTB-1716-100		16.7	16		100	2			
RTB-1816-100		17.7	16		100	2			
RTB-2016-110		19.7	16		110	2	CCMT060204	SCR-RTB2.5	T8
RTB-2016-150		19.7	16	60	150	2			
RTB-2216-110		21.7	16		110	2			
RTB-2316-110		22.7	16		110	2			
RTB-2420-120		23.7	20	70	120	2			
RTB-2520-120		24.7	20		120	2			
RTB-2620-130		25.7	20		130	2			
RTB-2720-130		26.7	20	30	130	2			
RTB-2820-130		27.7	20		130	2			
RTB-3025-160		29.7	25		160	2			
RTB-3025-190		29.7	25		190	2			
RTB-3225-160		31.7	25		160	2			
RTB-3525-160		34.7	25	90	160	2			
RTB-3532-230		34.7	32		230	2	CCMT09T304	SCR-RTB3.5	T15
RTB-3625-160		35.7	25		160	2			
RTB-4025-160		39.7	25		160	2			
RTB-4032-250		39.7	32		250	2			
RTB-4232-200		41.7	32		200	2			
RTB-4532-200		44.7	32		200	2			
RTB-4832-200		47.7	32	45	200	2			
RTB-5032-200		49.7	32		200	2			
RTB-5232-200		51.7	32		200	2			
RTB-5532-200		54.7	32		200	2			

ITEM	產品代號	SPECIFICATION 規格 (mm)				TEETH 刃數	INSERT 刀片型號	SCREW 刀片螺絲	WHLNCH 柄中	
		D	d	R	L1					
ARD-2.5R-1010-100.2		10	10	2.5	100	2				
ARD-2.5R-1110-100.2		11	10	2.5	100	2	RD.0501	SCR-RD2.0	T6	
ARD-2.5R-1212-100.2		12	12	2.5	100	2				
ARD-2.5R-1312-100.2		13	12	2.5	100	2				
ARD-3R-1212-130.2		12	12	2.5	130	2	RD.06T1	SCR-RD2.5	T7	
ARD-4R-1614-130.2		16	14	4	30	130	2			
ARD-4R-1716-130.2		17	16	4		130	2			
ARD-4R-2018-150.3		20	18	4		150	3	RD.0803	SCR-RD2.5	T8
ARD-4R-2120-150.3		21	20	4		150	3			
ARD-4R-2525-150.4		25	25	4		150	4			
ARD-4R-2625-150.4		26	25	4		150	4			
ARD-5R-2020-150.2		20	20	5		150	2			
ARD-5R-2025-126.2		20	25	5	55	126	2			
ARD-5R-2020-200.2		20	20	5		200	2			
ARD-5R-2120-150.2		21	20	5		150	2			
ARD-5R-2525-150.2		25	25	5		150	2			
ARD-5R-2525-150.3		25	25	5		150	3	RD.10T3	SCR-RD3.0	T9
ARD-5R-2525-250.2		25	25	5	30	250	2			
ARD-5R-2525-250.3		25	25	5		250	3			
ARD-5R-3025-150.3		30	25	5		150	3			
ARD-5R-3025-150.4		30	25	5		150	4			
ARD-5R-3025-250.3		30	25	5		250	3			
ARD-5R-3025-250.4		30	25	5		250	4			

Copy Milling Cutter
仿形銑刀桿

SKD SKT NI OX MB SC C-HOLE

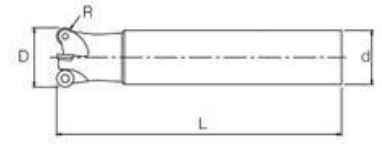

ITEM 產品代號	SPECIFICATION 規格				TEST# 刃數	INSERT 刀片型號	INSERT SCR 刀片螺絲	CLAMP 壓板	CASSETTE SCR 刀夾螺絲	WRENCH 扳手
	D	d	R	L						
ART-GR25-150	25	25	G	150	2	RPMT1204	SCR-ART4	CL-ART	SCR-M3.5	T15
ART-GR32-150	32	32	G	150	2					
ART-GR32-200	32	32	G	200	2					
ART-GR32-250	32	32	G	250	2					
ART-GR35-150	35	32	G	150	3					
ART-GR35-200	35	32	G	200	3					
ART-GR40-150	40	32	G	150	3					
ART-GR40-150.4	40	32	G	150	4					
ART-GR40-200	40	32	G	200	3					
ART-GR50-150	50	32	G	150	4					
ART-GR50-200	50	32	G	200	4					

Copy Milling Cutter
鎖牙式仿形銑刀頭

SKD NI MB SC C-HOLE

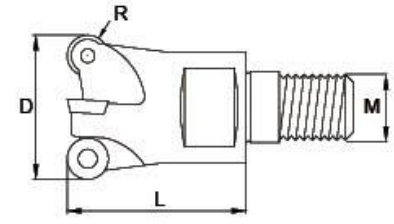

ITEM 產品代號	SPECIFICATION 規格				TEST# 刃數	INSERT 刀片型號	SCREW 刀片螺絲	WRENCH 扳手
	D	R	M	L				
ARD-0510-05.2A	10	2.5	M5		2	RD.0501	SCR-RD2.0	T6
ARD-0510.55-05.2A	10.55	2.5	M5	18	2			
ARD-0511-05.2A	11	2.5	M5		2			
ARD-0612-05.3A	12	2.5	M6		3	RD.06T1	SCR-RD2.5	T7
ARD-0613-05.3A	13	2.5	M6	19	3			
ARD-0612-06.2A	12	3	M6		2			
ARD-0613-06.2A	13	3	M6		2	RD.0803	SCR-RD2.5	T8
ARD-0816-08.2A	16	4	M8	23	2			
ARD-0817-08.2A	17	4	M8		2			
ARD-1020-08.3A	20	4	M10	30	3	RD.10T3	SCR-RD3.0	T9
ARD-1021-08.3A	21	4	M10		3			
ARD-1225-08.4A	25	4	M12	35	4			
ARD-1226-08.4A	26	4	M12		4	RP.1204	SCR-PP4.0	T15
ARD-1020-10.2A	20	5	M10	30	2			
ARD-1021-10.2A	21	5	M10		2			
ARD-1225-10.3A	25	5	M12	35	3	RP.1204	SCR-PP4.0	T15
ARD-1226-10.3A	26	5	M12		3			
ARD-1225-12.2A	25	6	M12	35	2			
ARD-1226-12.2A	26	6	M12		2	RP.1204	SCR-PP4.0	T15
ARD-1632-12.3A	32	6	M16	43	3			
ARD-1635-12.3A	35	6	M16		3			
ARD-1640-12.4A	40	6	M16		4			

Copy Milling Cutter
仿形銑刀盤

SAE SKD NI OX MB SC C.HOLE

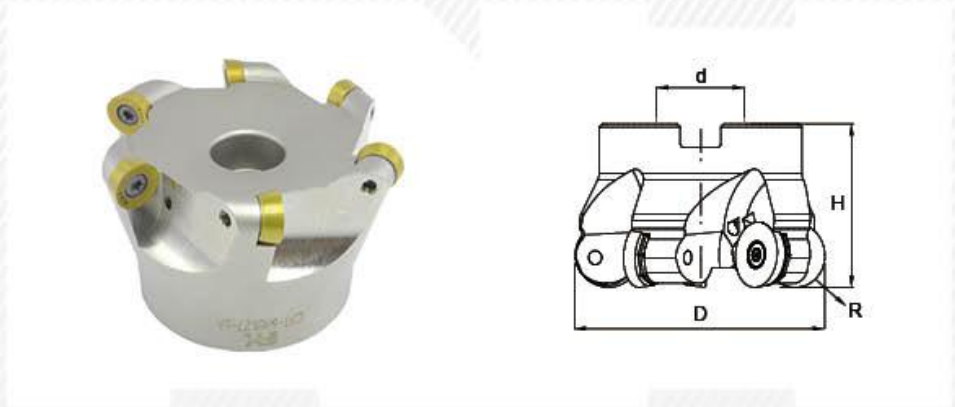

Copy Milling Cutter
仿形銑刀桿

SKD NI WT



ITEM	產品代號	SPECIFICATION				TEETH 刃數	INSERT 刀片型號	INSERT CO. 刀片廠牌	CLAMP 壓板	CLAMP SCR. 壓板螺絲	WRENCH 扳手
		D	d	d*	H						
ARD-5R50-2204		50	-	22	45	4	RDMT10T3	SCR-HRS4	-	-	T9
ART-GR50-2204		50	25.4	22	45	4	RPMT 1204MP	SCR-ART4L	CL-ART	SCR-ART3.5	T15
ART-GR63-2205		63	25.4	22	50	5					
ART-GR80-2706		80	25.4	27	50	6					
ART-GR100-3207		100	31.75	32	55	7					

● 訂購時請註明內孔 (d) 尺寸
Please note the diameter of "d" when you order.

ITEM	產品代號	SPECIFICATION				TEETH 刃數	INSERT 刀片型號	SCREW 刀片螺絲	WRENCH 扳手
		D	d	L1	L				
WC234-4R20-120		20	20	50	120	3	ROMX0803	SCR-RO3	T8
WC234-4R25-140		25	25	60	140	3			
WC234-4R32-170		32	32	80	170	4			

Copy Milling Cutter
仿形銑刀桿

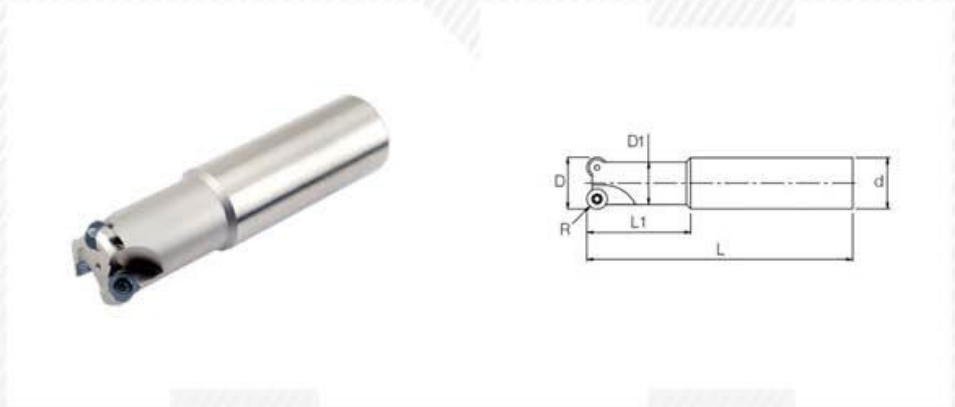

ITEM	產品代號	SPECIFICATION 規格 (mm)					TEETH 刃數	INSERT 刀片型號	SCREW 刀片螺絲	WRENCH 扳手
		D	D1	d	L1	L				
	NSP08-1616-120	16	14	16	50	120	1	QPMT0803	SCR-NSP3	T8
	NSP08-2020-130	20	18	20	50	130	2			
	NSP08-2020-180	20	18	20	40	180	2-3			
	NSP08-2525-130	25	21	25	50	130	3	QPMT10T3	SCR-NSP3.5	T15
	NSP10-2525-180	25	21	25	40	180	2-3			
	NSP10-2525-130	25	21	25	50	130	2			
	NSP10-3232-130	32	28	32	50	130	3			
	NSP10-3532-130	35	31	35	50	130	3			

Copy Milling Cutter
一體式仿形銑刀桿



ITEM	產品代號	SPECIFICATION 規格 (mm)				TEETH 刃數	INSERT 刀片型號	SCREW 刀片螺絲	WRENCH 扳手
		D	R	L1	L				
	BT40-NSP0820.90.3	20	4	40	90	3	QPMT0803	SCR-NSP3	T8
	BT40-NSP0825.100.4	25	4	50	100	4			
	BT40-NSP0825.130.4	25	4	80	130	4			
	BT40-NSP1025.100.3	25	5	50	100	3	QPMT10T3	SCR-NSP3.5	T15
	BT40-NSP1032.100.4	32	5	50	100	4			
	BT40-NSP1032.130.4	32	5	80	130	4			

Copy Milling Cutter
仿形銑刀桿

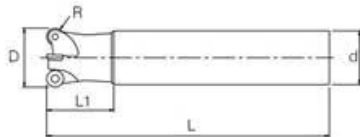

Copy Milling Cutter
鎖牙式仿形銑刀頭

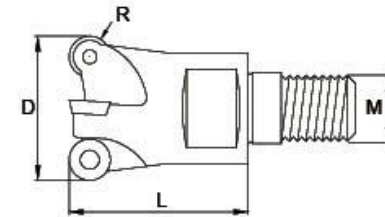

ITEM	產品代號	SPECIFICATION 規格 (mm)				TEST# 刃數	INSERT 刀片型號	SCREW 刀片螺絲	WALNUT 松子	
		D	d	R	L1					
SRD05-1002.10-100		10	10			100	2			
SRD05-1102.10-100		11	10	2.5		100	2	RDWH0501	SCR-RD2.0	T6
SRD05-1203.12-100		12	12			100	3			
SRD05-1303.12-100		13	12			100	3			
SRD07-1603.16-150		16	16			150	3			
SRD07-1703.16-150		17	16		30	150	3			
SRD07-1703.16-200		17	16			200	3			
SRD07-2003.20-150		20	20			150	3			
SRD07-2103.20-150		21	20	3.5		150	3	RDWT0702	SCR-RD2.5	T8
SRD07-2103.20-200		21	20			200	3			
SRD07-2504.25-150		25	25			150	4			
SRD07-2604.25-150		26	25			150	4			
SRD07-2604.25-200		26	25			200	4			
SRD10-3503.32-150		35	32			150	3			
SRD10-3503.32-200		35	32			200	3			
SRD10-3503.32-250		35	32	5	50	250	3	RDWT1003	SCR-RD3.5	T15
SRD10-3503.32-300		35	32			300	3			
SRD10-3504.32-150		35	32			150	4			
SRD10-3504.32-200		35	32			200	4			

ITEM	產品代號	SPECIFICATION 規格 (mm)				TEST# 刃數	INSERT 刀片型號	SCREW 刀片螺絲	WALNUT 松子
		D	R	M	L				
SRD05-1002M5		10	2.5	M5		2			
SRD05-1102M5		11	2.5	M5	18	2	RDHW0501	SCR-RD2.0	T6
SRD05-1203M6		12	2.5	M6		3			
SRD05-1303M6		13	2.5	M6	19	3			
SRD07-1603M8		16	3.5	M8	23	3			
SRD07-1703M8		17	3.5	M8		3			
SRD07-2003M10		20	3.5	M10	30	3			
SRD07-2103M10		21	3.5	M10		3	RDMT0702	SCR-RD2.5	T8
SRD07-2504M12		25	3.5	M12		4			
SRD07-2505M12		25	3.5	M12	35	5			
SRD07-2604M12		26	3.5	M12		4			
SRD07-3505M16		35	3.5	M16		5			
SRD10-3503M16		35	5	M16	43	3	RDWT1003	SCR-RD3.5	T15
SRD10-3504M16		35	5	M16		4			

Copy Milling Cutter
仿形銑刀桿

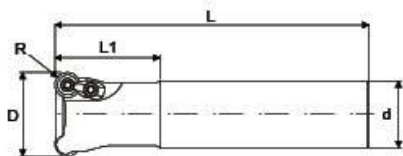

Copy Milling Cutter
仿形銑刀桿

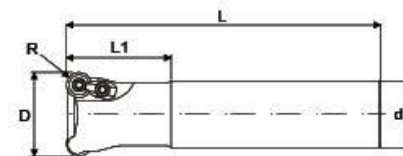

ITEM	產品代號	SPECIFICATION 規格 (mm)				TEETH 刃數	INSERT 刀片型號	SCREW 刀片螺絲	WRENCH 扳手
		D	d	R	L1				
MRP2-5R25-150		25	25	5	40	150	RPMW1003	SCR-MRP5 SCR-W3/16S	T10
MRP2-5R25-200		25	25	5		200			
MRP2-5R25-250		25	25	5	60	250			
MRP2-5R25-300		25	25	5		300			
MRP2-5R30-150		30	25	5		150			
MRP2-5R30-200		30	25	5		200			
MRP2-5R30-250		30	25	5		250			
MRP2-5R30-300		30	25	5		300			
MRP3-5R35-150		35	32	5	45	150			
MRP3-5R35-200		35	32	5		200			
MRP3-5R35-250		35	32	5		250			
MRP3-5R35-300		35	32	5		300			
MRP3-5R40-150		40	32	5		150			
MRP3-5R40-200		40	32	5		200			
MRP3-6R35-150		35	32	6		150			
MRP3-6R35-200		35	32	6		200			
MRP3-6R35-250		35	32	6		250			
MRP3-6R40-150		40	32	6		150			
MRP3-6R40-200		40	32	6		200			
								RPMW1203	SCR-MRP4L SCR-W3/16S

ITEM	產品代號	SPECIFICATION 規格 (mm)				TEETH 刃數	INSERT 刀片型號	SCREW 刀片螺絲	CLAMP 壓板	CLAMP SCREW 壓板螺絲	WRENCH 扳手
		D	d	R	L1						
HNS-4R12-120		12	12		40	120	FDMT0802	SCR-HRS3	CL-4R	SCR-HRS3.5	
HNS-4R12-150		12	12		70	150					
HNS-4R16-120		16	16	4	35	120					
HNS-4R16-150		16	16		35	150					
HNS-4R17-150		17	17		70	150					
HNS-4R20-150		20	20		50	150					
HNS-4R20-200		20	20	70	200						
HNS-4R21-150		21	21	70	150						
HNS-5R25-150		25	25	5	60	150					
HNS-5R25-200		25	25		120	200					
HNS-5R25-250		25	25		120	250					
HNS-5R25-300		25	25		140	300					
HNS-5R30-150		30	25		50	150					
HNS-5R30-200		30	25		50	200					
HNS-5R30-250		30	25		50	250					
HNS-5R30-300		30	25		50	300					
HNS-5R32-150		32	32		70	150					
HNS-5R32-200		32	32		120	200					
HNS-5R32-250		32	32		140	250					
HNS-5R32-300		32	32		140	300					
HNS-5R35-150		35	32	50	150						
HNS-5R35-200		35	32	50	200						
HNS-5R35-250		35	32	50	250						
HNS-5R35-300		35	32	50	300						
HNS-5R35-350		35	32	50	350						
HNS-5R40-150		40	32	50	150						
HNS-5R40-200		40	32	50	200						
HNS-6R35-150		35	32	6	50	150					
HNS-6R35-200		35	32		50	200					
HNS-6R40-150		40	32		50	150					
HNS-6R40-200		40	32		50	200					
							FDMT10T3	SCR-HRS3.5	CL-5R	SCR-HRS4	T15
							FDMT12D4	SCR-HRS4L	CL-ERS3.5	SCR-HRS3.5	

日昇精技

RI HSIUNG
PRECISION
TECH

Copy Milling Cutter 仿形銑刀盤

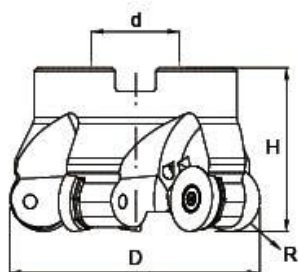

日昇精技

RI HSIUNG
PRECISION
TECH

Copy Milling Cutter 仿形銑刀桿

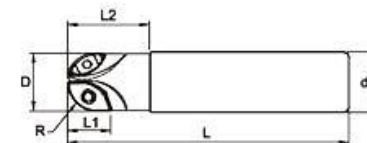

ITEM 產品代號	SPECIFICATION 規格 (mm)				TEETH 刃數	INSERT 刀片型號	INSERT SCR 刀片螺絲	CLAMP 壓板	CLAMP SCR 壓板螺絲	WRENCH 扳手
	D	d	d*	R						
HRS-5R50-2204	50	25.4	22		4					
HRS-5R63-2205	63	25.4	22	5	5	RDMT10T3	SCR-HRS4	CL-5R	SCR-HRS3.5	T15
HRS-6R50-2204	50	-	22	6	4	RDMT1204	SCR-HRS4L	CL-ESR3.5		
HRS-6R63-2205	63	25.4	22		5					
HRS-8R50-2203	50	-	22		4					
HRS-8R63-2204	63	25.4	22		5					3/4
HRS-8R66-2705	66	25.4	27	8	4	RDMT1604	SCR-HRS5	-	SCR-W1/4S	T20
HRS-8R80-2705	80	25.4	27		5					
HRS-8R100-3205	100	31.8	32		5					
HRS-8R116-3206	116	31.8	32		6			CL-8R116H	SCR-HRS6	T20/T25

● 訂購時請註明內孔 (d) 尺寸
Please note the diameter of "d" when you order.

ITEM 產品代號	SPECIFICATION 規格 (mm)					TEETH 刃數	INSERT 刀片型號	SCREW 刀片螺絲	WRENCH 扳手
	D	d	L1	L2	L				
KB218-1220-110.060	12	20	10	30	110	2	218.20-060	DS-1805	T06
KB218-1620-120.080	16	20	14	40	120	2	218.20-080	DS-2506	T08
KB218-2025-135.100	20	25	18	70	135	2	218.20-100	DS-3007	T09
KB218-2525-150.125	25	25	22	70	150	2	218.20-125	DS-4009	T15
KB218-3232-150.160	32	32	28	70	150	2	218.20-160	DS-4011	T15
KB218-4042-200.200	40	42	35	100	200	2	218.20-200	DS-5013	T20

Copy & Plunge

Copy & Plunge

Copy Milling Cutter
仿形銑刀桿

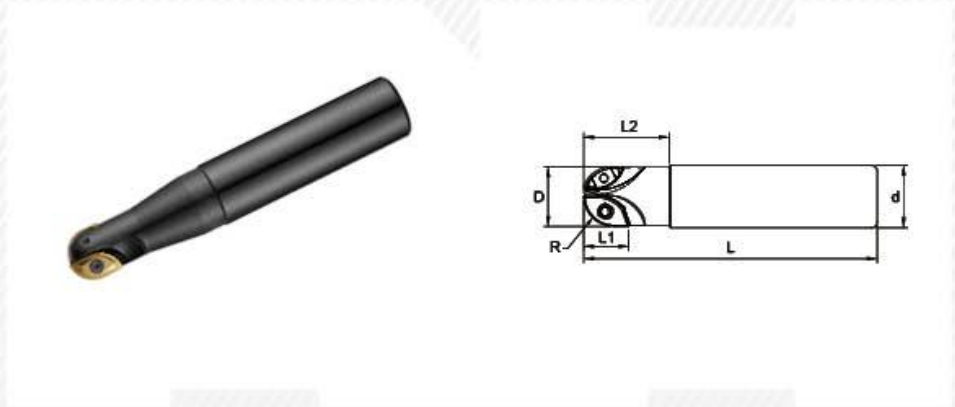

ITEM	產品代號	SPECIFICATION 規格 (mm)					TEETH 刃數	INSERT 刀片型號	SCREW 刀片螺絲	WRENCH 扳手
		D	d	L1	L2	L				
KBZC-1616-130		16	16	18	35	130	2	ZCET080CE ZCET080SE	SC-2501	T8
KBZC-1620-180		16	20	18	50	180	2			
KBZC-2025-140		20	25	18	52	140	2	ZCET100CE ZCET100SE	SC-3006	T10
KBZC-2025-200		20	25	18	52	200	2			
KBZC-2525-150		25	25	23	62	150	2	ZCET125CE ZCET125SE	SC-4005	T15
KBZC-2532-200		25	32	23	97	200	2			
KBZC-3032-160		30	32	28	72	160	2	ZCET150CE ZCET150SE	SC-5001	T20
KBZC-3032-250		30	32	28	92	250	2			
KBZC-3232-160		32	32	28	50	160	2	ZCET160CE ZCET160SE		
KBZC-3232-250		32	32	28	80	250	2			

Copy Milling Cutter
仿形銑刀頭

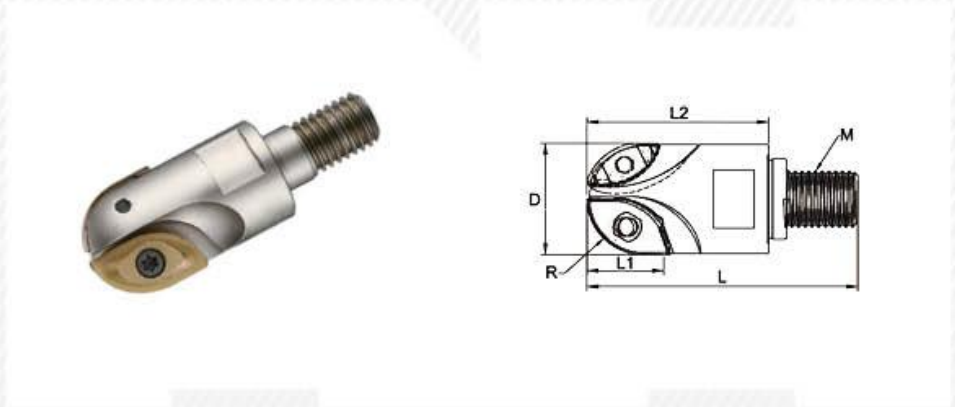

ITEM	產品代號	SPECIFICATION 規格 (mm)					TEETH 刃數	INSERT 刀片型號	SCREW 刀片螺絲	WRENCH 扳手
		D	M	L1	L2	L				
KBZC-0816-080.2		16	M8	18	32	49	2	ZCET080CE ZCET080SE	SC-2501	T8
KBZC-1020-100.2		20	M10	18	38	57	2	ZCET100CE ZCET100SE	SC-3006	T10
KBZC-1225-125.2		25	M12	23	38	60	2	ZCET125CE ZCET125SE	SC-4005	T15
KBZC-1230-150.2		30	M12	28	42	64	2	ZCET150CE ZCET150SE	SC-5001	T20
KBZC-1632-160.2		32	M16	28	43	66	2	ZCET160CE ZCET160SE		

Copy Milling Cutter
仿形銑刀桿

SAE SKD NI SC WT

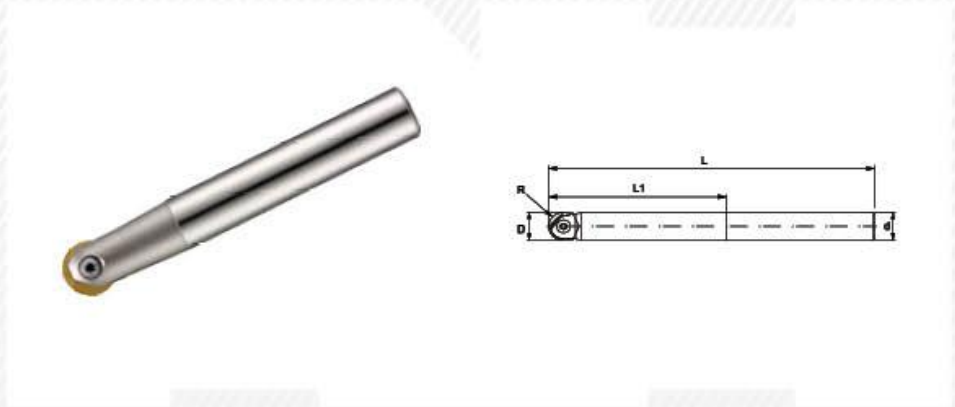

Copy Milling Cutter
鎖牙式仿形銑刀頭

SAE SKD NI SC WT

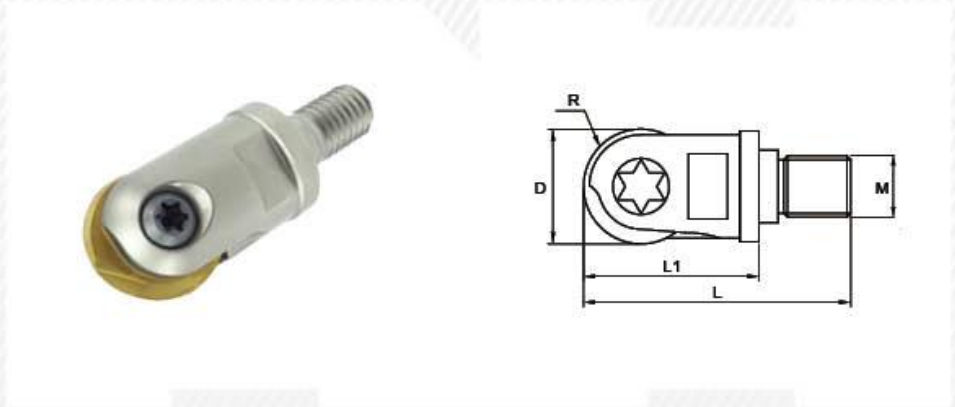

ITEM	產品代號	SPECIFICATION					INSETT 刀片型號	SCREW 刀片螺絲	WRENCH 扳手
		D	d	R	L1	L			
W2139-4R10-100		8	10	4	25	100	P3200D08	SCR-CR4	T8
W2139-4R10-140		8	10		30	140	219.19-080		
W2139-5R10-130		10	10		30	130	P3200D10	SCR-CR5	T15
W2139-5R12-150		10	12	5	25	150	219.19-100		
W2139-6R12-130		12	12	6	30	130	P3200D12	SCR-CR6	
W2139-6R16-160		12	16		25	160	219.19-120		
W2139-8R16-150		16	16	8	36	150	P3200D16	SCR-CR8	T20
W2139-8R20-200		16	20		30	200	219.19-160		
W2139-10R20-160		20	20	10	45	160	P3200D20	SCR-CR10	
W2139-10R25-250		20	25		30	250	219.19-200		
W2139-12.5R25-180		25	25	12.5	45	180	P3200D25	SCR-CR12	
W2139-12.5R32-250		25	32		35	250	219.19-250		
W2139-15R32-200		30	32	15	50	200	P3200D30	SCR-CR15	T30
W2139-15R32-250		30	32		35	250	219.19-250		
W2139-16R32-200		32	32	16	50	200	P3200D32	SCR-CR16	
W2139-16R42-280		32	42		45	280	219.19-320		

ITEM	產品代號	SPECIFICATION					INSETT 刀片型號	SCREW 刀片螺絲	WRENCH 扳手
		D	M	R	L1	L			
W2139-5RM05		10	M5	5	21	33	QPMT0803 QPMT0803	SCR-CR5	T15
W2139-6RM06		12	M6	6	42	38	P3200D12 219.19-120	SCR-CR6	
W2139-8RM08		16	M8	8	26	45	P3200D16 219.19-160	SCR-CR8	T20
W2139-10RM10		20	M10	10	35	53	P3200D20 219.19-200	SCR-CR10	
W2139-12.5RM12		25	M12	12.5	41	63	P3200D25 219.19-250	SCR-CR12	
W2139-15RM12		30	M12	15	41	63	P3200D30	SCR-CR15	T30
W2139-16RM16		32	M16	16	42	65	P3200D32 219.19-320	SCR-CR16	

Copy Milling Cutter
鎖牙式仿形銑刀頭

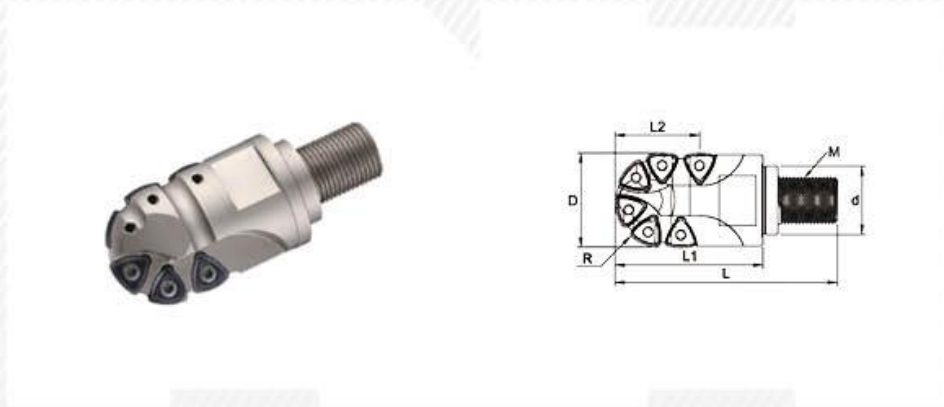

ITEM	產品代號	SPECIFICATION 規格 (mm)						INSERT 刀片型號	SCREW 刀片螺絲	WRENCH 扳手
		D	d	L1	L2	L	R			
WHBN-1020-20.R10		20	18	33	20	52	10	P2633.-R10	SC-2515	T8
WHBN-1225-21.R12.5		25	23	42	21	64	12.5			
WHBN-1230-23.R15		30	23	50	23	72	15	P2633.-R14	SC-4023	T15
WHBN-1632-23.R16		32	23	50	23	72	16			
WHBN-1840-38.R20		40	26	65	38	101	20	P2633.-R25	SC-5002	T20
WHBN-2550-45.R25		50	36	80	45	119	25			

Plunge Milling Cutters
插銑刀盤

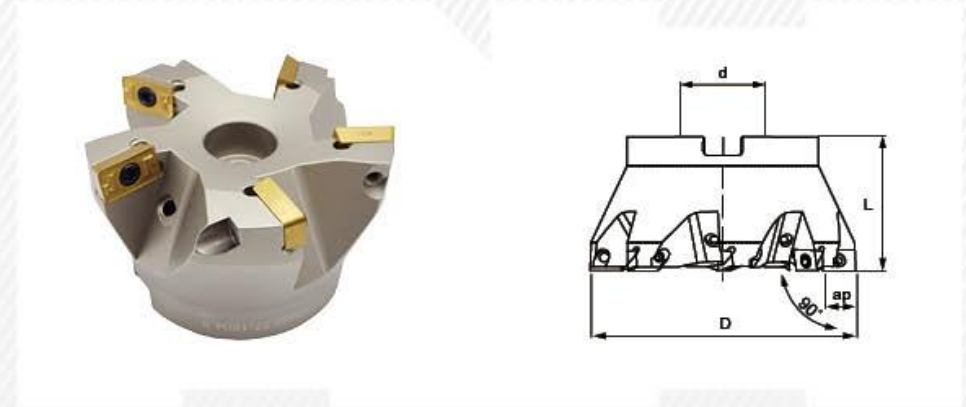

ITEM	產品代號	SPECIFICATION 規格 (mm)					TEETH 刃數	INSERT 刀片型號	SCREW 刀片螺絲	WRENCH 扳手
		D	d	L	ap					
AAP-FM63.22-1604.4A		63	22	40	15	4	AP-1604..L	SC-4004	T15	
AAP-FM80.27-1604.5A		80	27	50	15	5				
AAP-FM100.32-1604.6A		100	32	50	15	6				
AAP-FM125.40-1604.8A		125	40	63	15	8				

Copy Milling Cutter
仿形銑刀桿

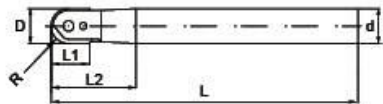

ITEM 產品代號	SPECIFICATION 規格 mm					INSERT 刀片型號	SCREW 刀片螺絲	SCREW 刀片螺絲	WRENCH 扳手	
	D	d	R	L1	L2					L
HBP-8R16-160	16	16			40	160	ZPFW163	SCR-AR8	SCR-HBP3.5	T15
HBP-8R20-130	16	20			50	130				
HBP-8R20-160	16	20	8	13	65	160				
HBP-8R20-200	20	20			65	200				
HBP-8R25-200	25	25			65	200				
HBP-10R20-200	20	20			40	200	ZPFW200	SCR-AR10	SCR-HBP5	T20
HBP-10R25-250	20	25	10	17	80	250				
HBP-12.5R25-200	25	25	2.5	22	45	200				

Cavity Milling Modular Cutter For Aluminium
鎖牙式鋁用仿形銑刀頭

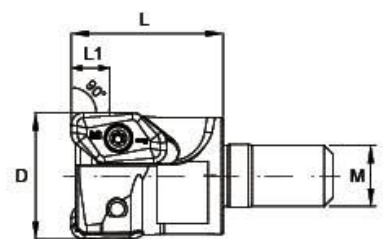

ITEM 產品代號	SPECIFICATION 規格 mm				TEETH 刃數	INSERT 刀片型號	SCREW 刀片螺絲	WRENCH 扳手
	D	M	L1	L				
AXP-1225-122A	25	M12		30	2	XP.12	SC-3504	T15
AXP-1632-123A	32	M16	7.5	40	3			
AXP-1640-123A	40	M16		40	3			

Cavity Milling Cutter For Aluminium
鋁用仿形銑刀盤

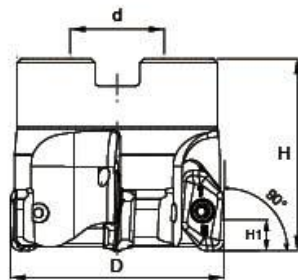

ITEM	產品代號	SPECIFICATION 規格 (mm)				TEETH 刃數	INSERT 刀片型號	SCREW 刀片螺絲	WRENCH 扳手
		D	d	H1	H				
AXP-FM50.22-124A		50	22			4			
AXP-FMG3.27-125A		G3	27	7.5	45	5	XP.12	SC-3504	T15
AXP-FM80.27-126A		80	27			6			
AXP-FM100.32-127A		100	32			7			

Modular Cylinder Holder
鎖牙式刀柄

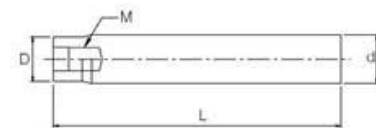

ITEM	產品代號	SPECIFICATION 規格 (mm)			
		D	d	M	L
MCH-D10M5-100		9.5	10	M5	100
MCH-D12M6-100		11.5	12	M6	100
MCH-D16M8-130		14	16	M8	130
MCH-D16M8-180		14	16	M8	180
MCH-D20M10-130		18	20	M10	130
MCH-D20M10-180		18	20	M10	180
MCH-D25M12-200		23	25	M12	200
MCH-D25M12-250		23	25	M12	250
MCH-D25M12-300		23	25	M12	300
MCH-D32M16-130		29	32	M16	130
MCH-D32M16-180		29	32	M16	180
MCH-D32M16-200		29	32	M16	200
MCH-D32M16-250		29	32	M16	250
MCH-D32M16-300		29	32	M16	300
MCH-D32M16-350		29	32	M16	350

Modular Anti-Vibration Carbide Holder 鎖牙式鎢鋼抗震刀柄



ITEM	產品代號	SPECIFICATION 規格 (mm)			
		D	d	M	L
MCHD-10M05-75		10	10	M5	75
MCHD-10M05-100		10	10	M5	100
MCHD-10M05-150		10	10	M5	150
MCHD-12M06-75		12	12	M6	75
MCHD-12M06-100		12	12	M6	100
MCHD-12M06-150		12	12	M6	150
MCHD-12M06-200		12	12	M6	200
MCHD-16M08-100		16	16	M8	100
MCHD-16M08-150		16	16	M8	150
MCHD-16M08-200		16	16	M8	200
MCHD-16M08-250		16	16	M8	250
MCHD-20M10-100		20	20	M10	100
MCHD-20M10-150		20	20	M10	150
MCHD-20M10-200		20	20	M10	200
MCHD-20M10-250		20	20	M10	250
MCHD-20M10-300		20	20	M10	300
MCHD-20M10-400		20	20	M10	400
MCHD-25M12-100		25	25	M12	100
MCHD-25M12-150		25	25	M12	150
MCHD-25M12-200		25	25	M12	200
MCHD-25M12-250		25	25	M12	250
MCHD-25M12-300		25	25	M12	300
MCHD-25M12-350		25	25	M12	350
MCHD-32M16-150		32	32	M16	150
MCHD-32M16-200		32	32	M16	200
MCHD-32M16-250		32	32	M16	250
MCHD-32M16-300		32	32	M16	300
MCHD-32M16-400		32	32	M16	400

Modular Cylinder Holder 鎖牙式刀柄

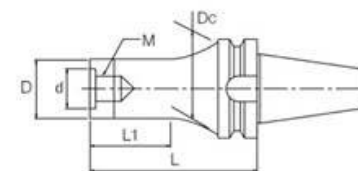

ITEM	產品代號	SPECIFICATION 規格 (mm)					
		D	Do	d	L	L1	M
BT30-M06-057		10	20	6.5			M6
BT30-M08-057		14	20	8.5	57	35	M8
BT30-M10-057		18	24	10.5			M10
BT30-M12-057		23	24	12.5			M12
BT30-M16-040		30	34.5	17	40	18	M16
BT40-M06-087		10	20	6.5		60	M6
BT40-M08-087		14	23	8.5	87		M8
BT40-M10-087		18	25	10.5		50	M10
BT40-M12-087		23	24	12.5			M12
BT40-M16-047		30	34.5		50	20	M16
BT40-M16-087		29	32	17	87	50	M16
BT40-M16-127		29	34		127	90	M16
BT50-M12-125		23	34	12.5	125	75	M12
BT50-M16-060		30	34.5		60	22	M16
BT50-M16-125		29	34	17	125	75	M16
BT50-M16-200		29	48		200	150	M16

Shell Mill Holders With Through Coolant Channels
面銑刀柄，帶內冷通路

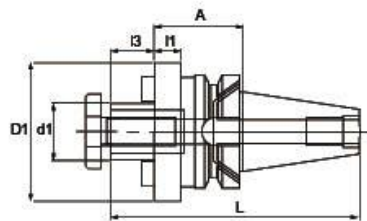

ITEM	產品代號	SPECIFICATION 規格 (mm)					
		d1	A	D1	L	l1	l3
E3414 5525 1645		16	45	38	127.4	18	17
E3414 5525 16100		16	100	38	182.4	73	
E3414 5525 2245		22	45	48	129.4	18	19
E3414 5525 22100		22	100	48	184.4	73	
E3414 5525 2745		27	45	60	131.4	18	21
E3414 5525 27100		27	100	60	186.4	73	
E3414 5525 3250		32	50	78	139.4	23	24
E3414 5525 4050		40	50	89	142.4		
E3414 5524 2745		27	45	48	131.4	18	21

● BT40 ADB

Shell Mill Holders With Through Coolant Channels
面銑刀柄，帶內冷通路

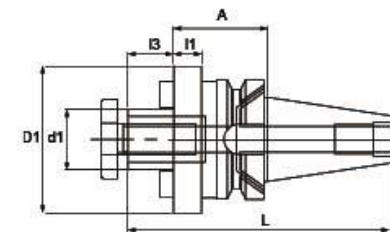

ITEM	產品代號	SPECIFICATION 規格 (mm)					
		d1	A	D1	L	l1	l3
E341G 5525 16100		16	100	38	218.8	62	17
E341G 5525 22100		22	100	48	220.8		
E341G 5525 22160		22	160	48	280.8	122	19
E341G 5525 2255		22	55	48	175.8	17	21
E341G 5525 2755		27	55	60	177.8	17	
E341G 5525 27100		27	100	60	222.8	62	24
E341G 5525 27160		27	160	60	282.8	122	
E341G 5525 32100		32	100	78	225.8	62	24
E341G 5525 32160		32	160	78	285.8	122	
E341G 5525 3255		32	55	78	180.8	17	27
E341G 5525 40100		40	100	89	228.8	62	
E341G 5525 40160		40	160	89	288.8	122	21
E341G 5525 4055		40	55	89	183.8	17	
E341G 5525 2755		27	55	48	177.8	28	21

● BT50 ADB

Shell Mill Holders With Through Coolant Channels
面銑刀柄，帶內冷通路

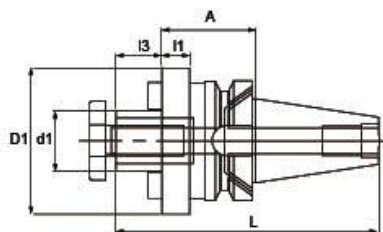

ITEM	產品代號	SPECIFICATION 規格 (mm)					
		d1	A	D1	L	I1	I3
E3469	5525 1635	16	35	38	120.4	16	17
E3469	5525 16100	16	100	38	185.4	81	
E3469	5525 2235	22	35	48	122.4	16	19
E3469	5525 22100	22	100	48	187.4	81	
E3469	5525 2745	27	45	60	134.4	26	21
E3469	5525 27100	27	100	60	189.4	81	
E3469	5525 3250	32	50	78	142.4	31	24
E3469	5525 4050	40	50	89	145.4		27
E3469	5524 2735	27	35	48	124.4	15.9	21

● DIN40 ADB

Shell Mill Holders With Through Coolant Channels
面銑刀柄，帶內冷通路

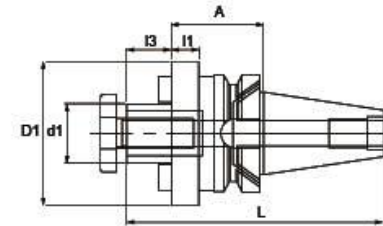

ITEM	產品代號	SPECIFICATION 規格 (mm)					
		d1	A	D1	L	I1	I3
E3471	5525 16100	16	100	38	218.7	81	17
E3471	5525 2235	22	35	48	155.7	16	
E3471	5525 22100	22	100	48	220.7	81	19
E3471	5525 22160	22	160	48	200.7	141	
E3471	5525 2740	27	40	60	162.7	21	
E3471	5525 27100	27	100	60	222.7	81	21
E3471	5525 27160	27	160	60	202.7	141	
E3471	5525 3250	32	50	78	175.7	31	
E3471	5525 32100	32	100	78	225.7	81	24
E3471	5525 32160	32	160	78	285.7	141	
E3471	5525 4050	40	50	89	178.7	31	
E3471	5525 40100	40	100	89	228.7	81	27
E3471	5525 40160	40	160	89	288.7	141	
E3471	5524 2740	27	40	48	162.7	20.9	21

● DIN50 ADB

Shell Mill Holders With Through Coolant Channels
面銑刀柄，帶內冷通路

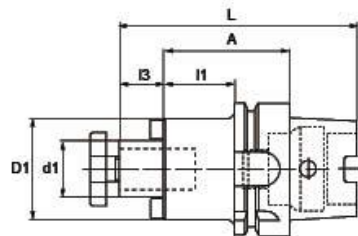

ITEM	產品代號	SPECIFICATION 規格 (mm)					
		d1	A	D1	L	l1	B
E9304 5525 1650		16	50	38	99	24	
E9304 5525 16100		16	100	38	149	74	17
E9304 5525 16145		16	145	38	194	119	
E9304 5525 2250		22	50	48	101	24	
E9304 5525 22100		22	100	48	151	74	19
E9304 5525 22160		22	160	48	211	134	
E9304 5525 2760		27	60	53	113	34	
E9304 5525 27100		27	100	53	153	74	21
E9304 5525 27160		27	160	53	213	134	
E9304 5525 3260		32	60	53	116	34	24
E9304 5525 32100		32	100	53	156	74	
E9304 5525 4060		40	60	53	119	34	27
E9304 5524 2760		27	60	48	113	34	21

● HSK-A63

Shell Mill Holders With Through Coolant Channels
面銑刀柄，帶內冷通路

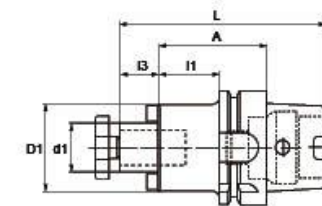

ITEM	產品代號	SPECIFICATION 規格 (mm)					
		d1	A	D1	L	l1	B
E9306 5525 16100		16	100	38	167	71	17
E9306 5525 2250		22	50	48	119	21	
E9306 5525 22100		22	100	48	169	71	19
E9306 5525 22160		22	160	48	229	131	
E9306 5525 2750		27	50	60	121	21	
E9306 5525 27100		27	100	60	171	71	21
E9306 5525 27160		27	160	60	231	131	
E9306 5525 3250		32	50	78	124	21	
E9306 5525 32100		32	100	78	174	71	24
E9306 5525 32160		32	160	78	234	131	
E9306 5525 4060		40	60	89	137	31	
E9306 5525 40100		40	100	89	177	71	27
E9306 5525 40160		40	160	89	237	131	
E9306 5524 2750		27	50	48	121	21	21

● HSK-A100