

INTRODUCES OF COMPANY

HOGA INDUSTRY CO., LTD.

was established in 1976 & located in Da'An District, Taichung City. We are one of the professional manufacturers who is specialized in making of excellent quality of Engine Valve, Valve Guide & Valve Seat Inserts for more than three decades. We offer comprehensive range of products suitable for all kind of petrol, diesel engine. Such as : Motorcycle, Passenger Car, Trucks, Heavy Duty Equipment & Marine and so on...

We have precise production equipment and manufacturing technology to meet customers' demands. We focus on every detail of production, in order to produce accurate dimension parts, establish a strict quality control process, to follow the spirit of quality control ISO/TS16949. From cutting, forging, turning, welding, grinding, appearance checking, 100% ultrasonic inspection to packing etc... Each stage of the process involved to strive for perfection, in order to produce best quality of Engine valve, Valve Guide & Valve Seat Inserts and achieve on-time delivery, also satisfies & meets customer needs.



QUALITY ASSURANCE

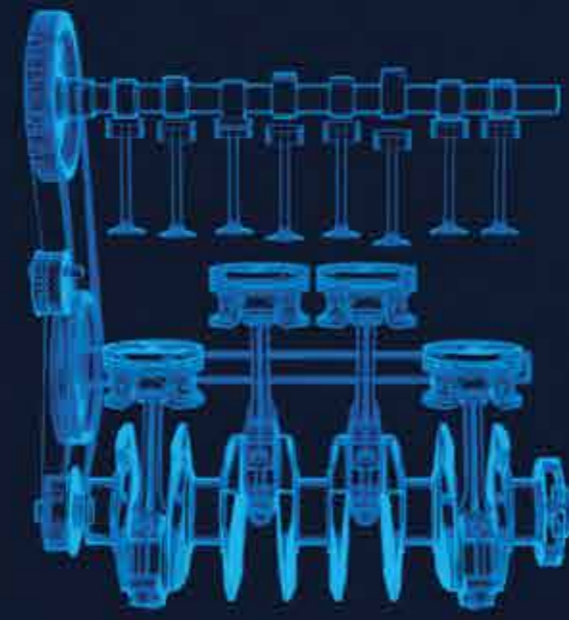

ENGINE VALVE VALVE GUIDE VALVE SEAT



HOGA INDUSTRY CO., LTD.

和佳工業股份有限公司

43964 台灣台中市大安區東西二路138-8 號
No.138-8, Dongxi 2nd RD, Da'An Dist., Taichung City, Taiwan R.O.C

TEL 886 4 2688 2777 FAX 886 4 2688 3777

E-mail jcmc1234@ms8.hinet.net

BRANDS SOLUTION | 品牌解決方案 Copyright © HOGA All Right Reserved 2018/04



HIGHLY PROFESSIONAL ACHIEVE PERFECTION

HIGHLY PROFESSIONAL ACHIEVE PERFECTION

高度專業，極緻完美

和佳工業股份有限公司，位於台中大安區，是引擎汽門、汽門導管及汽門閥座的專業製造廠商，產品種類多元齊全，適用於各類汽、機車、船舶....等引擎使用。

我們擁有精密的生產設備與加工製造技術，專注每一個生產細節，為了製造出準確無暇的尺寸，建立嚴格的品質管制流程，依循ISO-9001/TS16949之品質精神，從切斷、鍛造成形，車削、噴焊、研磨、外觀檢查、超音波全檢，到外盒包裝...等，每一階段的流程，鉅細靡遺，力求完美，才能製造出高品質的汽門、汽門導管及汽門閥座，達到準時交貨，滿足客戶需求。



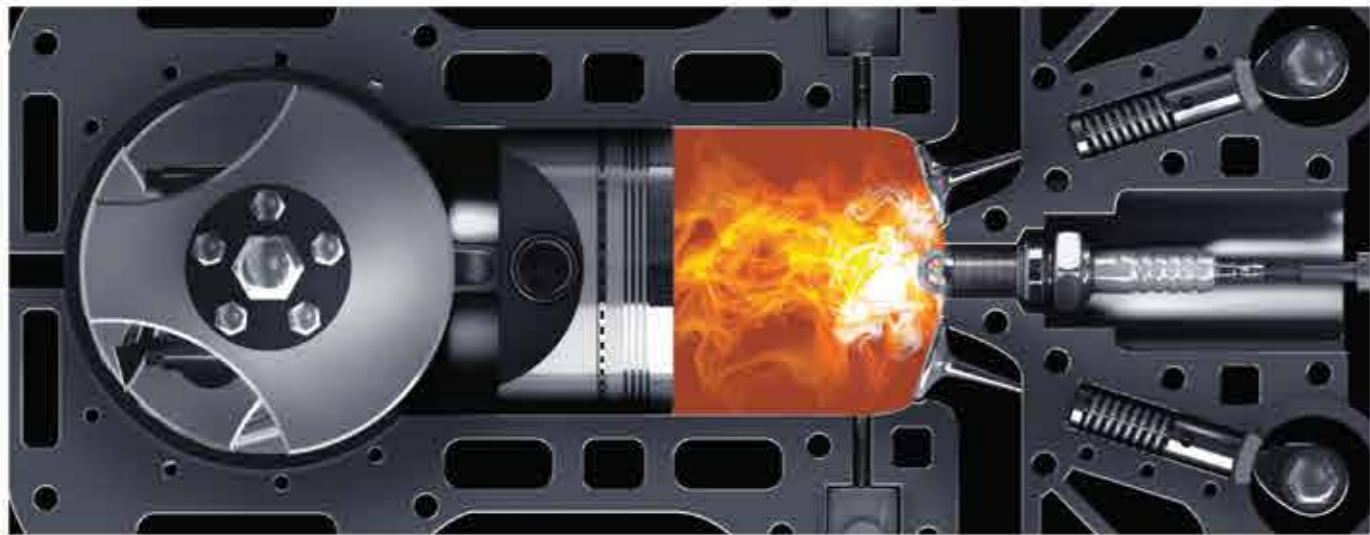

先進設備，高效能生產

「引擎汽門」採用SUH3及SUH35、NCF-751等，皆為世界各O.E.M汽、機車廠所選定之標準，同時也具有耐磨、耐蝕、在高溫下組織依然穩定、耐熱良好等特性。

「汽門導管」材質採用FC-25，硬度達HRB92~102；其孔徑採德國最新技術：無屑加工、光滑度高、表面硬度強，可減少引擎汽門在高度活動下造成的磨損，本身的耐磨程度比傳統加工方式增強一倍以上。

「汽門閥座」採用CNC機械加工方式一體成形，產出的精密尺寸與高級品質，均達到世界各知名零件專業廠商之要求；尺寸及各項加工處理，另有「客製化」生產服務。



ASSEMBLING & QUALITY CONTROL



ADVANCED EQUIPMENT EFFICIENT PRODUCTION

"Engine Valve" material used in SUH3, SUH35, NCF 751 etc... The specification of these material meets O.E.M. standard & are selected by the world leading Automobile, Motorcycles makers. These materials offer properties of anti-wear, anti-corrosion, heat-resistance and stable composition at high working temperature.

"Valve Guide" made by material of FC 25, Hardness achieve HRB 92~102; The making of VD processing from German technology, no burr processing, fine-surface finished, and high surface hardness, to reduce the wear of Engine Valve. The anti-wear performance of valve guide is double effective than a traditional processing.

The forming of "Valve Seat Insert" finished by CNC machining process, to produce a nice quality & high precision parts. In order to meet & satisfy our worldwide customer. We do customization service on any dimension & necessary treatment if required.

HOGA INDUSTRY / ENGINE VALVE / VALVE GUIDE / VALVE SEAT

ENGINE VALVE DIMENSION SPECIFICATION

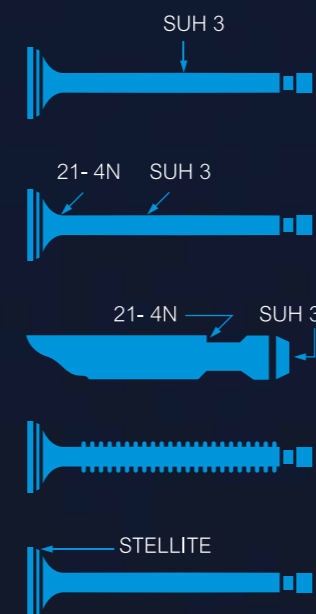
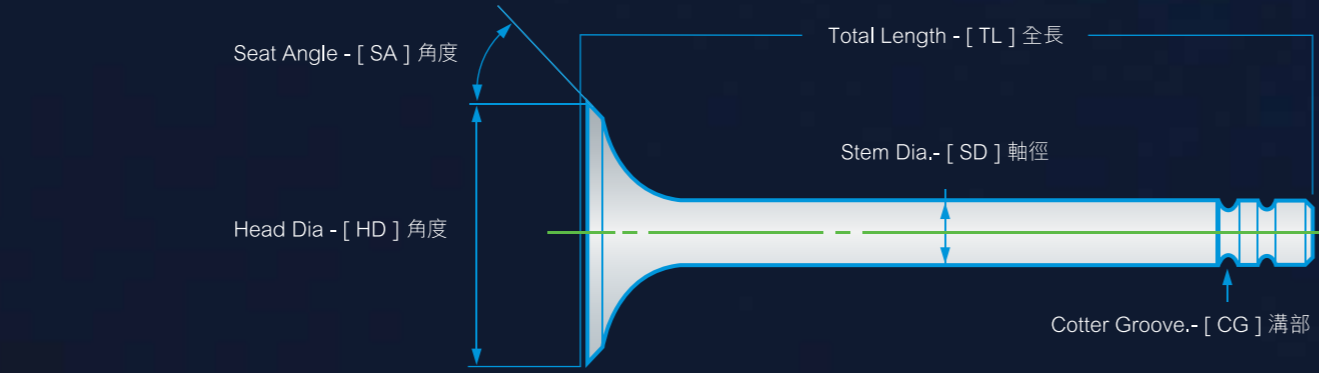

W	單一體 JIS SUH3	One-piece JIS SUH 3
B	雙體 21-4N 及 JIS SUH3 在桿部溶接	Two - piece valve 21-4N & JIS SUH3 welded on stem
X	單一體 21-4N, 端部溶接	One-piece 21-4N tip-welded = TIP welded
C	表面處理 Cc: 硬鍍硬鉻 Ct: Tufftrided 鹽浴氮化 Ch: 高週波熱處理	SURFACE TREATMENT Hard-chromium plated = CR Tufftrided = TF1 Induction hardened
F	Stellite 溶接在汽門盤面	Stellite welded on valve face

VALVE SEAT DIMENSION VALVE GUIDE DIMENSION

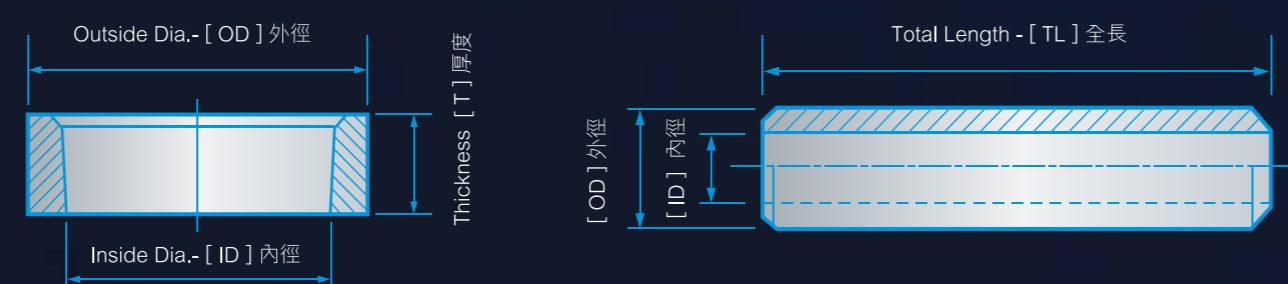

SHAPE OF COTTER GROOVE (CG)

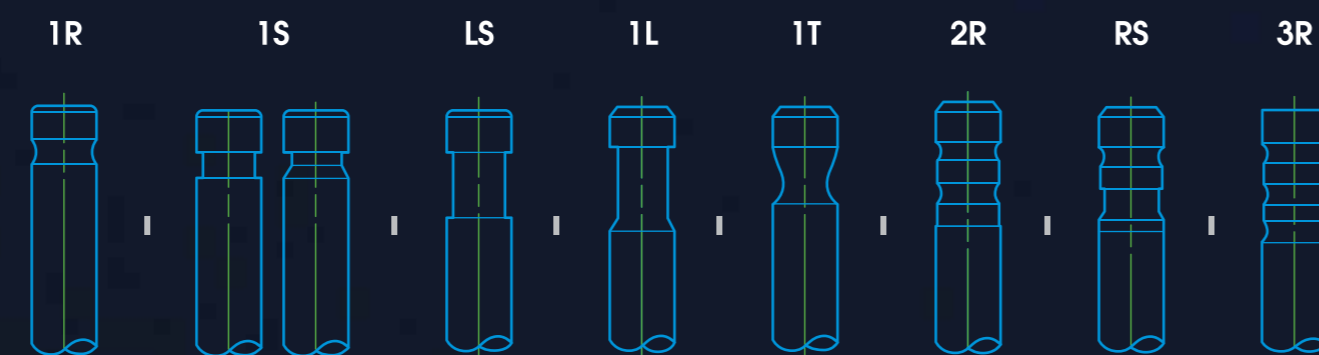

CHEMICAL COMPOSITION MATERIAL

	C	Si	Mn	P	S	Ni	Cr	Mo	Cu	W	Applied to	
MARTENSITIC STEEL	SUH1	0.40-0.50	3.00-3.5	≤0.60	≤0.030	≤0.030	≤0.5	7.50-9.50	--	--	In Valve	
	SUH11	0.45-0.55	1.00-2.00	≤0.60	≤0.030	≤0.030	--	7.50-9.50	--	--	In Valve	
	SUH3 1.4731	0.30-0.45	1.80-2.50	≤0.60	≤0.030	≤0.030	≤0.6	10.00-12.00	0.70-1.30	≤0.30	In Valve Ex Valve Seat Insert	
	SUH4 [XB]	0.75-0.85	1.75-2.25	0.20-0.60	≤0.030	≤0.030	1.15-1.65	19.00-20.50	--	≤0.30	Valve Seat [Seat Insert]	
SKD11	1.40-1.60	≤0.40	≤0.60	≤0.030	≤0.030	≤0.5	11.0-13.0	0.80-1.20	--	--	Valve Seat [Seat Insert]	
AUSTENITIC STEEL	SUH31	0.30-0.45	1.50-2.50	≤0.60	≤0.040	≤0.030	13.00-15.00	14.00-16.00	--	≤0.30	2.00-3.00	Valve Seat [Seat Insert]
	SUH35 1.4871 21-4N, EV8	0.8-0.58	≤0.35	8.00-10.00	≤0.010	≤0.030	3.25-4.50	20.00-22.00	--	--	--	Ex Valve
	SUH36	0.475-0.575	≤0.25	8.00-10.00	≤0.030	0.040-0.090	3.25-4.50	20.00-22.00	--	≤0.30	--	Ex Valve
	SUH37 [21-12N]	0.15-0.25	0.75-1.00	1.00-1.50	≤0.025	≤0.025	10.50-12.50	22.00-20.00	--	≤0.30	--	Ex Valve
	SUH38	0.25-0.35	≤1.0	≤1.2	0.18-0.25	≤0.030	10.00-12.00	19.00-21.00	1.80-2.5	≤0.30	--	Ex Valve
NCF751	0.10 Max	0.5 Max	1.00 Max	--	--	70.0	14.00-17.00	--	--	--	--	

	C	Cr	W	Fe	CO	Hardness HRC
STELLITE #1	2.5	30.0	12.0	3.0 Max.	Bal.	54
STELLITE #6	1.0	28.0	4.0	3.0 Max.	Bal.	44
STELLITE #12	1.35	29.0	8.0	2.0	Bal.	47

JIS SUH 3

燒入硬化的特殊耐熱合金，具有磁性適用於進汽門及內部生熱較低的引擎。

JIS SUH 35(21-4N)

高級耐熱合金鋼，非磁性奧斯田鋼在高溫之下耐磨及具有耐蝕性的優點，適用於排汽門與重工業引擎。

STELLITE

鈷鉻鎢合金鋼，接於汽門之盤面(重工引擎排氣門)。具耐高溫、耐蝕的效果。

JIS SUH 3

Hardened special heat resistant alloy, magnetic and suitable for intake valve and lower heat engines.

JIS SUH 35(21-4N)

High-class heat resistant alloy, non-magnetic Austenitic steel offers the advantage of anti-wear and anti-corrosion at high temperature. Suitable for exhaust valves and heavy duty engines.

STELLITE

Cobalt/Chromium/Wolfram alloy steel welded on the seat face of valves(exhaust valve of heavy duty engines). Offers the advantage of heat resistant and anti-corrosion.

HOGA 公司沿革

- 1976 | 06 ▶ 沙鹿廠區設立登記
- 1980 | 08 ▶ 引擎汽門投入生產
- 1990 | 06 ▶ 取得國內羽田汽車廠大發、標緻(DAIHATSU、PEUGEOT) 供應商資格
- 1993 | 01 ▶ 取得國內機車OEM廠供應商資格
- 1995 | 08 ▶ 與中山科學院、臺大慶齡國際焊接技術研究室、國立成功大學、TJING LING INTL. Welding of Taiwan University, National Chen-Kung University and Feng Chia University for the production of engine parts, R&D of production technology.
- 1996 | 06 ▶ 通過商品檢驗局ISO-9002國際品質認證
- 2001 | 09 ▶ 加強開拓歐美市場，與和太工業股份有限公司合作改組為「和佳工業股份有限公司」
- 2004 | 04 ▶ 通過2000年版ISO-9001，完成船泊汽門、汽門導管、汽門座開發生產
- 2006 | 12 ▶ 完成研發船泊汽門最大尺寸：盤面112mm/軸徑24.9mm/長度570mm以上
- 2007 | 05 ▶ 提升大型汽門品質，投入「西德超音波探傷機」
- 2007 | 08 ▶ 為確保焊接密度95%及提升大尺寸規格，熔接導入「TIP油壓點焊機」；提升品保檢驗精確度投入「萬能精密投影機」
- 2008 | 02 ▶ 完成研發船泊汽門座團特殊表面溶射處理；研發單位專業提升，另開發船泊相關其它零件
- 2009 | 03 ▶ 完成研發船泊汽門導管最大尺寸：長度279mm/內徑71.03mm/外徑102.035mm以上
- 2010 | 05 ▶ 開發義大利材料採購，分散材料採購風險
- 2010 | 07 ▶ 提高檢驗品質及提升產品同心度，導入「新型同心度量具」
- 2010 | 11 ▶ 提升鍛造能力，導入「立式雙座電氣加熱擠壓溫度顯示鍛縮機」，確保加熱溫度穩定
- 2012 | 05 ▶ 開發德國材料採購，分散材料採購風險
- 2012 | 12 ▶ 新廠房完成，並遷入及生產
- 2013 | 03 ▶ 為更提升進料檢驗及製程檢驗硬度，確保精確品質，導入「新型洛氏硬度計HR-200」
- 2013 | 09 ▶ 導入新技術(Queuch-Polish-Quench)，簡稱「QPQ鹽浴複合處理技術」，大幅度提高金屬表面硬度，進而增加耐磨性、抗蝕性，是一種新的金屬表面強化性技術；(NITRIDED)離子氮化處理&氣體滲氮優異的耐磨性、耐疲勞性、耐蝕性及耐高溫
- 2013 | 11 ▶ 為配合客戶要求及自我提升品質，導入「新型表面粗糙度檢查儀器」
- 2014 | 11 ▶ 正式取得美國ASR協會通過認可ISO/TS16949品質認證系統

VALVE GUIDE VALVE SEAT ENGINE VALVE



HISTORY OF COMPANY



Sha-Lu plant was established.
Production of engine valves.
Became one of the O.E.M. qualified supplier to domestic DAIHATSU, PEUGEOT.
Became one of the O.E.M. qualified supplier to domestic local Motor-scooter factories.
Cooperation with Chung-Shan Institute of Science & Technology, TJING LING INTL. Welding of Taiwan University, National Chen-Kung University and Feng Chia University for the production of engine parts, R&D of production technology.
ISO-9002 certified by the BUREAU of Merchandise & Inspection.
In order to strengthen & developing on the Europe and America market, cooperated with HOTA Industry and reorganized to established HOGA Industry CO., Ltd.
Passed of ISO-9001/ Ver. 2000 quality certified system. Accomplished of develops & produce of Engine valve, Valve Guide & Valve Seat Inserts for marine application.
Accomplished & develops Largest size of Engine valve : H/D = 112mm/m, S/D = 24.9 m/m, T/L = 570 m/m
In order to upgrade parts' quality by using Ultrasonic flaw detector tester to prevent any defective parts to be released out.
The key to using TIP welding machine, welding area of more than 95% after welding process. Enhance the accuracy of Q/C inspection skill by using "Optical Comparator" imports from JQC.
Completed & develops Valve Seat Inserts surface with special treatment by Thermal Spray process. Also, other related parts for Marines' application.
Accomplished & develops Largest size of Valve guide: Overall Length=279 m/m, I/D= 71.03 m/m, O/D= 102.035 m/m
Sourcing for new valve steel supplier in Italy, to decreasing / dispersal risk of material procurement.
To improve & enhance product quality & concentricity, imports of "New concentricity gauge".
To enhance forging capacity, introducing "Vertical two-seater electric heating up-setter with temperature display", ensuring that the heating temperature is stable.
Sourcing for new valve steel supplier in Germany, to decreasing / dispersal risk of material procurement.
To better improve testing result of Hardness on raw material and inspection process to ensure the accuracy of the quality, Imported "New Rockwell hardness tester" HR-200.
Introducing new technology (Quench- Polish- Quench), referred to as "QPQ salt bath processing technology" significantly improve the hardness of the metal surface, thus increasing the wear resistance, corrosion resistance, is a new metal surface hardening technology; (NITRIDED) ion nitriding & gas nitriding excellent wear resistance, fatigue resistance, corrosion resistance at high temperature.
In order to meet customers' requirement & self-improvement, imported new "Surface Roughness Inspection" equipment.
Made a formal accreditation by the ASR, Hoga Industry had earn & passed ISO/TS16949 quality certification system.